

Introduction

This manual provides information needed to operate and understand the vehicle and its components. More detailed information is contained in the *Owner's Warranty Information for North America* booklet, and in the vehicle's workshop and maintenance manuals.

Custom-built Freightliner vehicles are equipped with various chassis and cab components. Not all of the information contained in this manual applies to every vehicle. For details about components in your vehicle, refer to the chassis specification pages included in all new vehicles and to the vehicle specification decal, located inside the vehicle.

For your reference, keep this manual in the vehicle at all times.

IMPORTANT: Descriptions and specifications in this manual were in effect at the time of printing. For the most up-to-date information visit <https://freightliner.com/> for the latest version of the driver's and maintenance manuals.

Freightliner reserves the right to discontinue models and to change specifications or design at any time without notice and without incurring obligation. Descriptions and specifications contained in this publication provide no warranty, expressed or implied, and are subject to revisions and editions without notice.

Environmental Concerns and Recommendations

Whenever you see instructions in this manual to discard materials, you should first attempt to reclaim and recycle them. To preserve our environment, follow appropriate environmental rules and regulations when disposing of materials.

Data Logging

This vehicle is equipped with a control module that performs data logging capabilities.

This vehicle is equipped with one or more devices that record specific vehicle data and may perform some of the same functionality as a regulated Event Data Recorder but the device(s) are not subject to, nor designed pursuant to, 49 C.F.R. Part 563.

The type and amount of data recorded varies depending on how the vehicle is equipped (such as the brand of engine, if an air bag is installed, or if the vehicle features a collision avoidance system, etc.). GPS location data, fault codes, and other technical data may be recorded.

This data may help provide a better understanding of the circumstances of a crash.

Personal data such as name, gender, and age are not recorded. However, other parties such as law enforcement, could combine the data logger's contents with the type of personally identifying data routinely acquired during a crash investigation.

Emissions and Fuel Efficiency Compliance

This vehicle must be regularly inspected and maintained as indicated in the *M2 Plus Maintenance Manual*, and in the *Pre- and Post-Trip Inspections and Maintenance* chapter in this manual, in order to continue satisfactory performance and ensure coverage of the vehicle under the manufacturer's warranty.

Many maintenance procedures ensure that the vehicle and engine continue to comply with applicable emissions standards. Maintenance procedures, using components engineered to comply with greenhouse gas emissions and fuel efficiency regulations, may be performed by an authorized Daimler Truck North America dealer, an independent outlet, or the vehicle owner or operator.

The vehicle owner is responsible for determining the suitability of replacement components to maintain compliance with federal and local jurisdictional regulations. Components including, but not limited to, tires, cab/sleeper side extenders, chassis fairings, bumper, hood, vehicle speed limiters, and idle reduction timers are specifically designed and manufactured to exacting standards for regulatory fuel efficiency and greenhouse gas emissions compliance. It is important that these components are always replaced with components that meet or exceed the performance of the originally installed components.

Foreword

Customer Assistance Center

Having trouble finding service? Call the Customer Assistance Center at 1-800-385-4357 or 1-800-FTL-HELP. For dealer referrals and breakdown support, call night or day, weekdays or weekends. For specification requests and all other concerns and inquiries, the Customer Assistance Center is available 6:00 A.M. to 3:30 P.M. PST Monday through Friday. Our people are knowledgeable, professional, and committed to following through to help you keep your truck moving.

Reporting Safety Defects

Vehicles domiciled in the USA thought to have a defect that could cause a crash, injury, or death, should immediately be reported to the National Highway Traffic Safety Administration (NHTSA) and Daimler Truck North America LLC.

If the NHTSA receives similar complaints, it may open an investigation; if it finds that a safety defect exists in a group of vehicles, it may order a recall and remedy campaign. However, NHTSA cannot become involved in individual problems between you, your dealer, or Daimler Truck North America LLC.

To contact NHTSA, call the Vehicle Safety Hotline toll-free at 1-888-327-4236 (TTY: 1-800-424-9153).

To e-mail NHTSA, go to <https://www.nhtsa.gov/safertruck>.

You can contact NHTSA by mail at: Administrator, NHTSA Headquarters, 1200 New Jersey Avenue SE, West Building, Washington, DC 20590.

For more information about motor vehicle safety, go to <https://www.nhtsa.gov/safertruck>

To contact Freightliner about a concern about a specific vehicle call the Customer Assistance Center at 1-800-385-4357 or complete a **Product Concern Form**.

© 2023–2023 Daimler Truck North America LLC. All rights reserved. Daimler Truck North America LLC is a Daimler company.

No part of this publication, in whole or part, may be translated, reproduced, stored in a retrieval system, or transmitted in any form by any means, electronic, mechanical, photocopying, recording, or otherwise, without the prior written permission of Daimler Truck North America LLC. For additional information, please contact Daimler Truck North America LLC, Service Systems and Documentation, P.O. Box 3849, Portland OR 97208–3849 U.S.A. or refer to <https://northamerica.daimlertruck.com/> and <https://freightliner.com/>.

Vehicles domiciled in Canada thought to have a defect that could cause a crash, injury, or death, should immediately be reported to Transport Canada and Daimler Truck North America LLC.

If Transport Canada receives similar complaints, it may open an investigation; if it finds that a safety defect exists in a group of vehicles, it may order a recall and remedy campaign. However, Transport Canada cannot become involved in individual problems between you, your dealer, or Daimler Truck North America LLC.

To contact Freightliner about a concern about a specific vehicle call the Customer Assistance Center at 1-800-385-4357 or complete a **Product Concern Form**.

To contact Transport Canada, call the Defect Investigations and Recalls Division toll-free in Canada at 1-800-333-0510 or 819-994-3328 in the Gatineau-Ottawa area or internationally.

You can also contact Transport Canada by mail at: Transport Canada, 330 Sparks Street, Ottawa, Ontario, K1A 0N5 Canada.

The following websites contain more information on Canadian recalls:

English: www.tc.gc.ca/recalls.

French: www.tc.gc.ca/rappels.

For additional road safety information, please visit the Road Transportation website:

English: www.tc.gc.ca/en/services/road

French: www.tc.gc.ca/fr/services/routier

Contents

Chapter		Page
	Introduction, Environmental Concerns and Recommendations, Data Logging, Emissions and Fuel Efficiency Compliance, Customer Assistance Center, Reporting Safety Defects	Foreword
1	Vehicle Identification	1.1
2	Vehicle Access	2.1
3	Instruments	3.1
4	Driver Controls	4.1
5	Cab Features	5.1
6	Detroit Assurance 5.0	6.1
7	Driver Assistance Features	7.1
8	Electrical System	8.1
9	Engine Starting, Operation, and Shutdown	9.1
10	Optional Engine Systems	10.1
11	Brake Systems	11.1
12	Steering System	12.1
13	Emissions	13.1
14	Automated and Automatic Transmissions	14.1
15	Manual Transmissions, Clutch, and Transfer Cases	15.1
16	Drive Axles	16.1
17	Fifth Wheels and Trailer Couplings	17.1
18	Headlight Aiming	18.1
19	Natural Gas Vehicle Information	19.1
20	Vehicle Appearance and Care	20.1
21	Pre- and Post-Trip Checklists	21.1
22	Pre- and Post-Trip Inspections and Maintenance	22.1
23	In an Emergency	23.1
24	Telematics Data	24.1
	Index	I.1

Vehicle Identification

Component Information Label	1.1
Component GWR Label	1.1
Federal Motor Vehicle Safety Standard Label	1.1
Canada Certification Label	1.1
Mexico Labeling	1.2
Emission Labels	1.3
Customer Assistance Label	1.6

Vehicle Identification

Component Information Label

NOTE: Labels shown in this chapter are examples only. Actual specifications may vary from vehicle to vehicle.

The component information label lists the vehicle model, identification number, and major component models and serial numbers.

For vehicles domiciled in Mexico, this label will be in Spanish as shown in [Fig. 1.1](#). Otherwise it will be printed in English as shown in [Fig. 1.2](#).

FREIGHTLINER		INFORMACION DE COMPONENTES	
FABRICADO POR: DAIMLER VEHICULOS COMERCIALES MEXICO		USE EL NUMERO DE IDENTIFICACION DE VEHICULO CUANDO ORDENE PARTES.	
MODELO: MM106064S	MODELO BASE: M2106	FECHA DE FABRIC: 06/20	
NO. DE SERIE VEH: 3ALHCYD28MDMN5409	CLIENTE: V83361	DIST. ENTRE EJE: 230	
MOTOR: DD8 7.7L 6 CYL SINGLE STAGE 280 HP / 220		MOTOR: 936913S0010863	
TRANS PRINCIPAL: ALLISON 3000 RDS AUTOMATIC		TRANSMISION: 6511714361	
PTO: DETROIT DA-F-12.0-3 12,000# FF1 71.5 KPI		PTO: 739912B0165864	
EJE DELANTERO: MT-40-14X 40,000# R-SERIES TANDEM REAR A		EJE INT. 1RO: DRA21199653	
EJE INT. 1RO:		EJE INT. 2DO:	
EJE INT. 2DO:		EJE INT. 3RO:	
EJE INT. 3RO:		EJE INT. 4TO:	
EJE INT. 4TO:		EJE INT. 5TO:	
EJE INT. 5TO:		EJE INT. 6TO:	
EJE INT. 6TO:		EJE TRASERO: DRA21199652	
EJE TRASERO: MT-40-14X 40,000# R-SERIES TANDEM REAR A		RELACION: 6.14	
PROVEEDOR DE PINTURA: ELITE EY PAINT C			
NO. DE PINTURA: CAB COLOR A: L0006EY			
		PARA INFORMACION COMPLETA DE PINTURA, VER HOJA DE ESPECIFICACIONES DE L VEHICULO.	
09/29/2020		f080196s	

Fig. 1.1, Component Information Label (Spanish)

FREIGHTLINER		COMPONENT INFORMATION	
MANUFACTURED BY: DAIMLER TRUCKS NORTH AMERICA LLC		SEE VEHICLE ID NO. WHEN ORDERING PARTS.	
MODEL: PX113064S T	BASE MODEL: CA113DC	DATE OF MFR: 07/15	
VEHICLE ID NO: 1FUJGBDV4GLZ9999	CUSTOMER: N00000	WHEELBASE: 164	
ENGINE MOD: DETROIT DD13 12.8L 410 HP / 1800 RPM, 20		ENGINE NO: 99999999999999	
MAIN TRANS MOD: DT12-DB-1450 HEAVY DUTY 12-SPEED DIRECT		TRANS NO: 99999999999999	
PTO MOD: MFS-12-143A 12,000# FF1 SINGLE FRONT AXL		PTO NO: MON99999999	
FRONT AXLE MOD: MT-40-14X 40,000# R-SERIES DUALTRAC 74-7		FRONT AXLE NO: FOR99999999	
1ST INT AXLE MOD:		1ST INT AXLE NO:	
2ND INT AXLE MOD:		2ND INT AXLE NO:	
3RD INT AXLE MOD:		3RD INT AXLE NO:	
4TH INT AXLE MOD:		4TH INT AXLE NO:	
5TH INT AXLE MOD:		5TH INT AXLE NO:	
6TH INT AXLE MOD:		6TH INT AXLE NO:	
REAR AXLE MOD: MT-40-14X 40,000# R-SERIES DUALTRAC 74-7		REAR AXLE NO: FOR99999999	
PAINT MFR: ELITE BC PAINT C		RATIO: 2.47	
PAINT CODE: CAB COLOR A: L0306EB			
		FOR COMPLETE PAINT INFORMATION SEE VEHICLE SPECIFICATION SHEET.	
06/21/2016		f080196	

Fig. 1.2, Component Information Label (English)

The component information label is located on the underside of the driver's sun visor.

Component GWR Label

NOTE: Vehicles manufactured for the Canadian market will have a Canadian Certification label instead of a component GWR label.

The component GWR label, shown in [Fig. 1.3](#), provides maximum GWR ratings for each component. For vehicles domiciled in Mexico, this label will be in Spanish as shown in [Fig. 1.4](#).

The component GWR label is located on the right-hand B-pillar as shown in [Fig. 1.5](#).

Federal Motor Vehicle Safety Standard Label

Tractors with or without fifth wheels manufactured for the U.S. are marked as certified by means of a federal motor vehicle safety standard (FMVSS) label, shown in [Fig. 1.6](#), which also lists suitable tire and rim combinations.

For vehicles domiciled in the United States, this label is attached to the left-hand side B-pillar as shown in [Fig. 1.7](#).

For vehicles manufactured for U.S./Canada operation, this label is applied next to the Canada certification label as shown in [Fig. 1.8](#).

Vehicles domiciled in Mexico are labeled with a Spanish weights and measurement label, as shown in [Fig. 1.9](#), that lists suitable tire and rim combinations.

The tire and rim combinations listed on these labels are those that can be installed on the vehicle for the given gross axle weight rating. Tires and rims installed on the vehicle at the time of manufacture may have a higher load capacity than that certified by the tire and rim label.

If the tires and rims currently on the vehicle have a lower load capacity than that shown on the tire and rim label, then the tires and rims determine the load limitations on each of the axles.

Trucks built without a cargo body that are intended for service in the U.S. have an incomplete FMVSS vehicle certification label. This label will be attached to the incomplete vehicle document included with the vehicle, and certifies that the vehicle conforms to all applicable FMVSS regulations in effect on the date of completion. The final certification label must be attached by the final-stage manufacturer.

Canada Certification Label

Complete tractors with fifth wheels manufactured for Canada or dual Canada/United States operations, are marked with a Canada certification label, shown in [Fig. 1.10](#), attached to the right-hand B-pillar.

Vehicle Identification

	MAXIMUM GWR BY COMPONENT (KG/LBS)	COMPONENT	FRONT AXLE	1ST INT AXLE	2ND INT AXLE	3RD INT AXLE	4TH INT AXLE	5TH INT AXLE	6TH INT AXLE	REAR AXLE	COMPONENT GVWR	
		AXLES:	(5443) 12000	(9072) 20000							(9072) 20000	CHASSIS:
		SUSPENSION:	(5443) 12000	(9072) 20000							(9072) 20000	ENG/TRANS:
		TIRES:	(5601) 12350	(9253) 20400							(9253) 20400	5TH WHEEL:
		RIMS:	(6713) 14800	(11612) 25600							(11612) 25600	PARK BRAKE:
		HUBS/SPOKES:	(6032) 13300	(10432) 23000							(10432) 23000	AXLE:
		BRAKES:	(6032) 13300	(9072) 20000							(9072) 20000	VIN: 1FUJGBDV4GLZZ9999
		STEERING:	(6032) 13300									f080200
		06/21/2016										

Fig. 1.3, Component GWR Label (English)

	PESO MAXIMO POR COMPONENTE (KG/LB)	COMPONENTE DELANTERO PRIMERO	1RO	2DO	3RO	4TO	5TO	6TO	EJE TRASERO	PESO BRUTO DEL COMPONENTE	
		EJE:	(5443) 12000	(9072) 20000						(9072) 20000	LARGUERO:
		SUSPENSION:	(5443) 12000	(9072) 20000						(9072) 20000	MOTOR/TRANS: (36288) 80000
		NEUMATICOS:	(5996) 13220	(10596) 23360						(10596) 23360	QUINTA RUEDA:
		RIM/AROS:	(6713) 14800	(13426) 29600						(13426) 29600	FRENO ESTAC:
		CUBOS/RADIOS:	(6032) 13300	(11793) 26000						(11793) 26000	EJE:
		FRENOS:	(5443) 12000	(9525) 21000						(9525) 21000	VIN: 3ALHCYD28MDMN5409
		DIRECCION:	(6032) 13300								f080200s
		09/29/2020									

Fig. 1.4, Component GWR Label (Spanish)

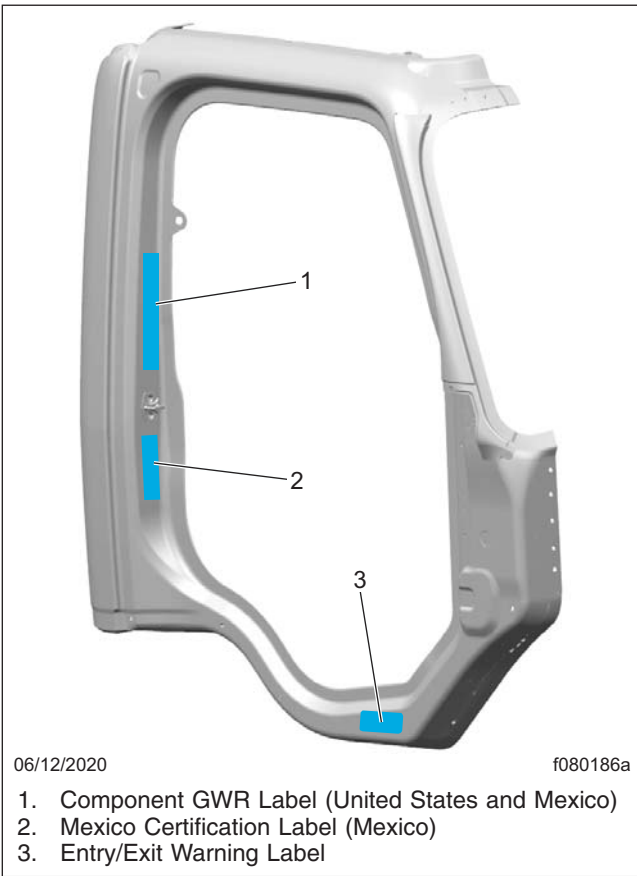

Fig. 1.5, Right-Hand Door Frame Labels

NOTE: Vehicles manufactured for Canada will have a Canada certification label instead of a component GWR label.

Trucks built without a cargo body and tractors built without a fifth wheel that are intended for service in Canada will have an incomplete Canada certification label attached to the left-hand B-pillar. After completion of the vehicle, a complete Canada certification label must be attached by the final-stage manufacturer to certify that the vehicle conforms to all applicable vehicle safety regulations in effect on the date of completion.

Mexico Labeling

Mexico Certification Label

The Mexico certification label states that the vehicle complies with the Normas Oficiales Mexicanas (NOMs) standards in effect on the date the vehicle was manufactured. See [Fig. 1.11](#).

Vehicles domiciled in Mexico will have a Mexico certification label applied to the right-hand B-pillar as show in [Fig. 1.5](#).

Spanish Weights and Measures Label

Vehicles with a Mexico certification label will also have a Spanish weights and measures label. See [Fig. 1.9](#) for an example.

Vehicle Identification

	MANUFACTURED BY: DAIMLER TRUCKS N.A. LLC	GAWR/PNBE	GAWR/PNBE	TIRES	RIMS	KPA	PSI	"S"
	DATE OF MFR: 07/15	KGS	LBS			COLD	COLD	
	GVWR/PNBV-KG: 23,587	FRONT AXLE: 5,443	12,000	275/80R22.5(G)	22.5X8.25	758	110	S
	GVWR/PNBV-LBS: 52,000	1ST INT AXLE: 9,072	20,000	445/50R22.5(L)	22.5X14.0	827	120	S
	THIS VEHICLE COMPLIES WITH ALL APPLICABLE FEDERAL MOTOR VEHICLE SAFETY STANDARDS IN EFFECT AT THE DATE OF MANUFACTURE SHOWN ABOVE.	2ND INT AXLE:						
	VEHICLE ID NO: 1FUJGBDV4GLZZ9999	3RD INT AXLE:						
	TYPE: TRUCK/TRACTOR TT/CT	4TH INT AXLE:						
	COUNTRY OF ORIGIN: U.S.A.	5TH INT AXLE:						
		6TH INT AXLE:						
		REAR AXLE: 9,072	20,000	445/50R22.5(L)	22.5X14.0	827	120	S
08/31/2020								f080199

Fig. 1.6, FMVSS Certification Label (complete vehicle)

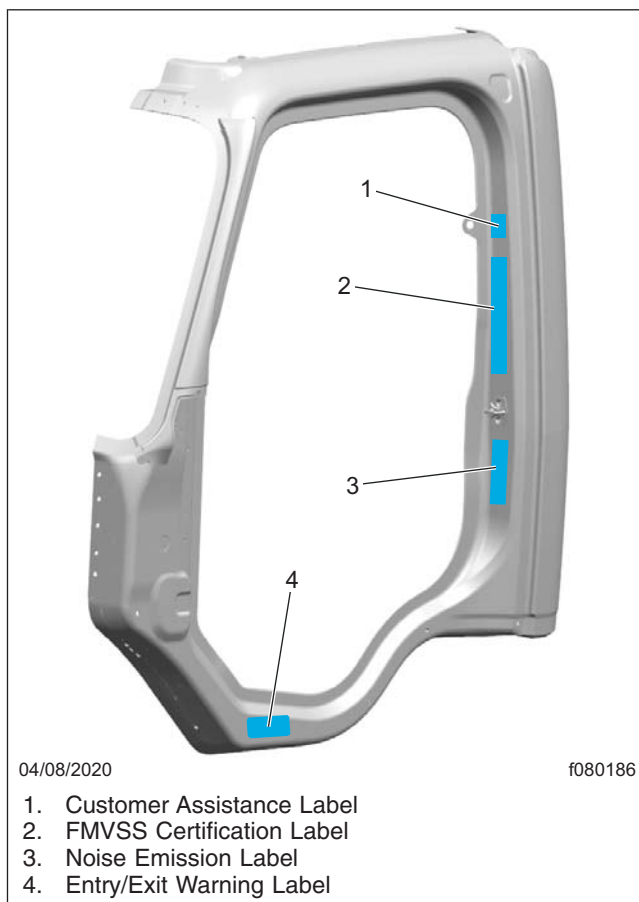

Fig. 1.7, Left-Hand B-Pillar Labels, United States

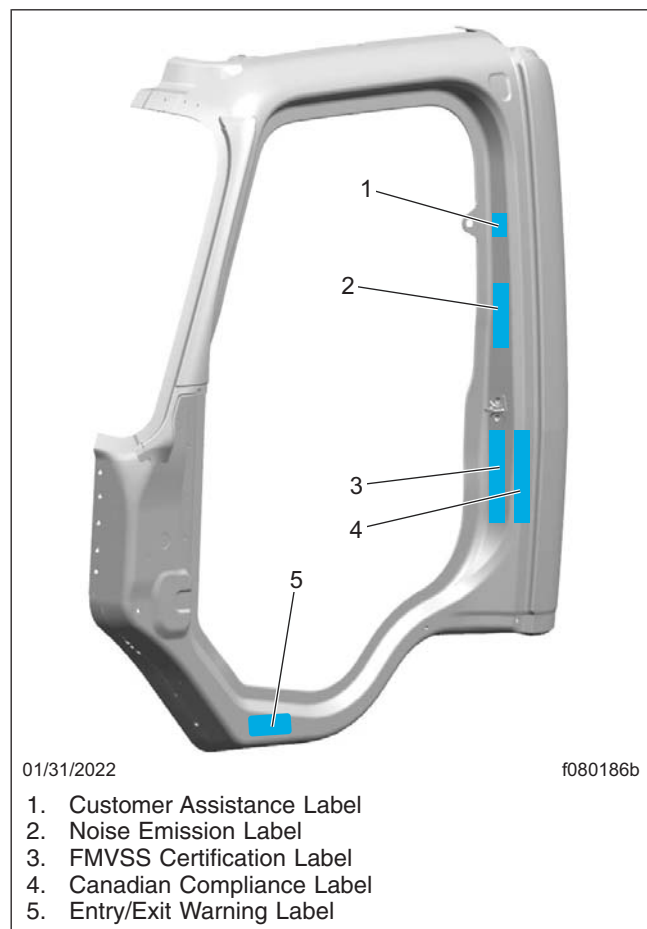

Fig. 1.8, Left-Hand B-Pillar Labels, Joint United States Canada Operation

Emission Labels

Aftertreatment System Indicators Label

Model year 2007 and later diesel engines in vehicles domiciled in the U.S. or Canada are required to meet all EPA exhaust gas emission regulations effective as per the applicable emission model year, and are

equipped with an emission aftertreatment system (ATS).

Vehicles domiciled outside of the U.S. and Canada may not have aftertreatment equipment, depending upon local statutory emissions guidelines.

	FABRICADO POR:	DAIMLER VEHICULOS COMERCIALES MEXICO	PV-KGS	PV-LBS	NEUMATICOS	RIM/AROS	KPA	PSI	"S"ENCILLA/ "D"OBLE	
	FECHA DE FABRICACION:	06/20					FRIO	FRIO		
	PBV (GVWR)-KG:	23,587	EJE DELANTERO:	5,443	12,000	11R22.5(H)	22.5X8.25	827	120	S
	PBV (GVWR)-LBS:	52,000	1RO:	9,072	20,000	11R22.5(G)	22.5X8.25	724	105	D
			2DO:							
			3RO:							
			4TO:							
			5TO:							
	NO. SERIE VEHICULO:	3ALHCYD28MDMN5409	6TO:							
	CHASIS-CABINA		EJE TRASERO:	9,072	20,000	11R22.5(G)	22.5X8.25	724	105	D
FABRIC. DE MEX.										
09/29/2020									f080199s	

Fig. 1.9, Spanish Weights and Measures Label

	VIN/NIV:	XXXXXXXXXXXXXXXXXX	CANADA CERTIFICATION	DATE OF MFR:	01/20
	THIS VEHICLE CONFORMS TO ALL APPLICABLE STANDARDS PRESCRIBED UNDER THE CANADIAN MOTOR VEHICLE SAFETY REGULATIONS IN EFFECT ON THE DATE OF MANUFACTURE / CE VEHICULE EST CONFORME A TOUTES LES NORMES QUI LUI SONT APPLICABLES EN VERTU DU REGLEMENT SUR LA SECURITE DES VEHICULES AUTOMOBILES DU CANADA EN VIGUEUR A LA DATE DE SA FABRICATION.				
	08/31/2020				f080218a

Fig. 1.10, Canada Certification Label

INFORMACION CONTROL DE ESPECIFICACIONES DE SEGURIDAD DEL VEHICULO DAIMLER VEHICULOS COMERCIALES MEXICO S. DE R.L. DE C.V. FECHA DE FABRICACION: 06/20 ESTE VEHICULO CUMPLE CON LA NORMA OFICIAL MEXICANA: NOM-068-SCT-2-2014 AL MOMENTO DE SER ENAJENADO.	
09/29/2020	 f080228s

Fig. 1.11, Mexico Certification Label

See [Table 1.1](#) and [Table 1.2](#) at the end of this chapter for additional information on what EPA and GHG regulations apply to different model years.

See [Fig. 1.13](#) for information on the driver's visor warning label for important warning indicators in the instrument cluster that pertain to the ATS.

It is a violation of U.S. federal law to alter exhaust plumbing, ATS, or other components in any way that would bring the engine/vehicle out of compliance with certification requirements [Ref: 42 U.S.C. S7522(a) (3)]. It is the owner's responsibility to maintain the vehicle so that it conforms to EPA regulations.

Vehicle Emission Control Information Label

Model year 2013 and later vehicles meet requirements as specified by GHG14, GHG17 and GHG21 regulations, respectively. These vehicles are equipped with components that increase fuel efficiency and reduce greenhouse gas (GHG) emissions. Components may include, but are not limited to, low-rolling resistance tires; aerodynamic

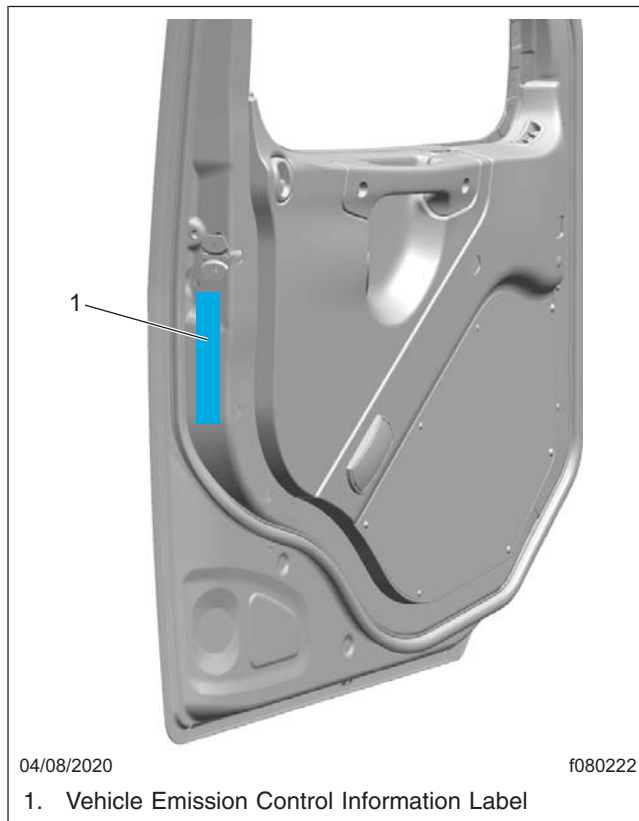

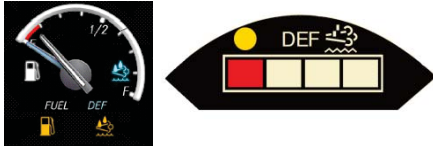

Fig. 1.12, Left-Hand Door Label

devices such as hood, cab side extenders, and fuel

Vehicle Identification

IMPORTANT	
<p style="text-align: center;">DPF Regen Needed</p> <div style="text-align: center;">  </div>	<ul style="list-style-type: none"> Diesel Particulate Filter (DPF) regeneration is needed. If flashing, regenerate as soon as possible. Engine derate possible.
<p style="text-align: center;">Hot Exhaust</p> <div style="text-align: center;">  </div>	<ul style="list-style-type: none"> Hot exhaust can cause fire. Keep flammables and people away from exhaust.
<p style="text-align: center;">DEF Refill Needed</p> <div style="text-align: center;">  </div>	<ul style="list-style-type: none"> Diesel Exhaust Fluid (DEF) level is low. Engine derate likely. Refill tank with certified DEF.
<p>See operator's manual or glove compartment card for complete instructions. 24-01656-000</p>	

10/23/2020 f080234

Fig. 1.13, ATS Indicators, EPA10 and Newer

tank fairings; vehicle speed limiters; and idle shutdown timers.

A vehicle emission control information label is located on the left-hand door, as shown in Fig. 1.12. Among other GHG relevant information, the label indicates the emission model year of the vehicle.

It is the owner's responsibility to maintain the vehicle so that it conforms to U.S. EPA and NHTSA regulations.

VEHICLE EMISSION CONTROL INFORMATION		
Manufactured By: DAIMLER TRUCKS NORTH AMERICA LLC	Date of Manufacture: 07/15	
VIN/NIV: 1FUJGBDV4GLZ29999	REGULATORY CLASS: High-roof day cab tractors above 33,000	
VEH FAMILY CD: GDTN2TRAC13C	pounds GVWR.	
GVWR-PNBV-KG: 23,587		
GVWR-PNBV-LBS: 52,000	EMISSION CONTROL IDENTIFIERS: LRRA, ARF, TGR	
<p style="font-size: x-small;">THIS VEHICLE COMPLIES WITH U.S. EPA AND CALIFORNIA REGULATIONS FOR 2016 HEAVY DUTY VEHICLES. See owner's manual for proper maintenance of this vehicle.</p>		
06/21/2016	f080198	

Fig. 1.14, Vehicle Emission Control Information Label

Noise Emission Control Labels

For vehicles manufactured for operation in the United States, an EPA noise emission control label, as shown in Fig. 1.15, is applied to attest that the vehicle conforms to United States EPA regulations for noise.

For vehicles manufactured for operation in Mexico, a Normas Oficiales Mexicanas (NOM) vehicle noise emission control label, as shown in Fig. 1.16, attests that the vehicle conforms to Mexican NOM regulations for noise.

For vehicles manufactured for dual Mexico/United States operation, both labels are applied.

It is the owner's responsibility to maintain the vehicle so it conforms to all applicable regulations (EPA, NOM).

IMPORTANT: Certain Freightliner incomplete vehicles may be produced for the United States market with incomplete noise control hardware.

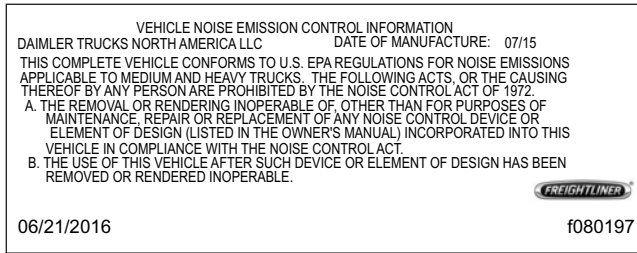

Fig. 1.15, EPA Vehicle Noise Emission Control Label (complete vehicle)

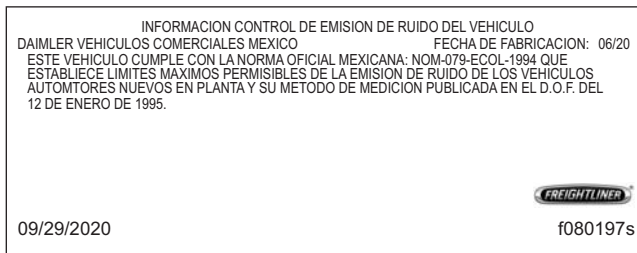

Fig. 1.16, NOM Vehicle Noise Emission Control Label (complete vehicle)

Such vehicles will have an incomplete vehicle noise emission control information label as shown in [Fig. 1.17](#). For these vehicles, it is the final-stage manufacturer's responsibility to complete the vehicle in conformity to the applicable regulations and label it for compliance.

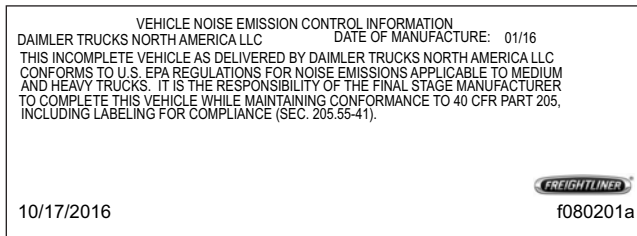

Fig. 1.17, EPA Vehicle Noise Emission Control Label (incomplete vehicle)

Certified Clean Idle Label

The California Air Resources Board (CARB) requires model year 2008 and newer heavy-duty diesel engines to meet CARB's Heavy-Duty Diesel Engine Idling Requirement in order to limit emissions of particulate matter and NOx.

Certified vehicles are equipped with a label, shown in [Fig. 1.18](#), that is placed near the bottom edge of the left-hand door.



Fig. 1.18, CARB Clean Idle Label

Customer Assistance Label

The customer assistance center telephone number is printed on the customer assistance label. The label also includes a QR code encoded with the vehicle identification number (VIN), readable by dealer apps, to bring up information about the vehicle.

For vehicles domiciled in Mexico this label will be in Spanish as shown in [Fig. 1.19](#). For vehicles domiciled in the United States it will be printed in English as shown in [Fig. 1.20](#).

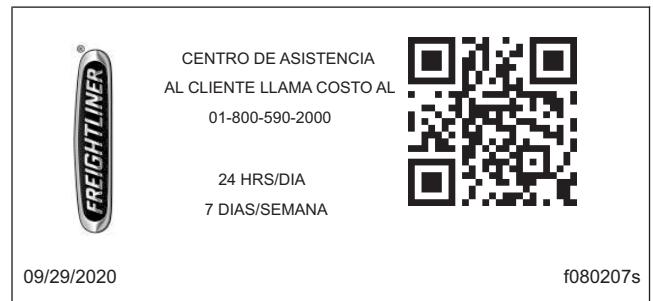

Fig. 1.19, Customer Assistance Label, Spanish

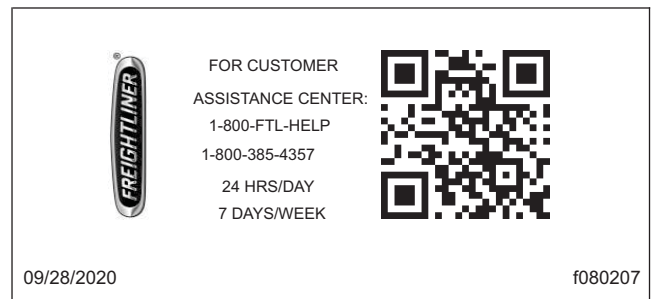

Fig. 1.20, Customer Assistance Label, English

Vehicle Identification

The customer assistance label is located on the left-hand B-pillar, as shown in [Fig. 1.7](#).

Emission Regulations by Model Year		
Model Year	Engine Regulation	Vehicle Regulation
2021–and later	EPA10, GHG21	GHG21

Table 1.1, Emission Regulations by Model Year

EPA Regulations	
Regulation	Emissions Components
EPA10 (Reduction of NOx emissions to 0.2 g/bhp-hr)	EPA07-type ATD, with additional selective catalyst reduction (SCR) technology that utilizes diesel exhaust fluid (DEF) to convert NOx to nitrogen and water vapor.
GHG21	GHG14/17 components plus additional components including, but not limited to, transmissions, axles, predictive technologies, idle reduction technologies for vocational vehicles, and tire pressure monitoring systems.

Table 1.2, EPA Regulations

2

Vehicle Access

Key, Door Locks, and Handles	2.1
Remote Keyless Entry	2.1
Grab Handles and Access Steps	2.2
Cab Entry and Exit	2.3
Back-of-Cab Access	2.4
Hood Opening and Closing	2.5

Vehicle Access

Key, Door Locks, and Handles

A common key operates the ignition switch and the door locks.

IMPORTANT: Each key is numbered. Record the number so a duplicate key can be made, if needed.

To unlock the driver's door from outside the cab using a key, insert the key and turn it one-quarter turn clockwise. See **Fig. 2.1**. To remove the key, turn it counterclockwise to the original position. Pull out on the door pull handle to open the door.

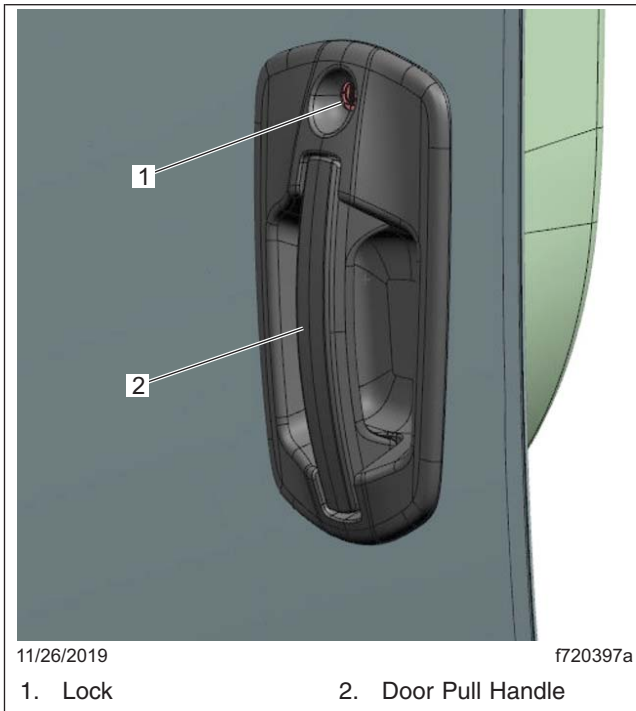

Fig. 2.1, Exterior Door Handle

To unlock the passenger's door from outside the cab, insert the key in the lock and turn it one-quarter turn counterclockwise. Turn the key clockwise to the original position to remove it.

NOTE: The cab door locks can be operated when the doors are open.

Close the door if it is open. To lock a door from outside the cab, insert the key in the lock and turn it in the direction opposite to the unlocking direction (counterclockwise for the driver's door, clockwise for the passenger's door).

To lock either door from inside the cab, push the lock button downwards. See **Fig. 2.2**.



Fig. 2.2, Door Interior

To open the door from the inside, lift up on the door lever. This will unlatch the door whether or not it is locked.

To unlock the door without unlatching it, pull the lock button upwards.

Remote Keyless Entry

Keyless Fob Use

! DANGER

Do not ingest the key fob battery. The button cell battery in this key fob is a chemical burn hazard.

Always keep the key fob and button cell batteries away from children.

Always safely dispose of used batteries.

If the button cell battery in this key fob is swallowed, it can cause severe internal burns within two hours and can lead to death. If you think a battery might have been swallowed or otherwise placed inside any part of the body, seek immediate medical attention.

If the battery compartment does not close securely, stop using the key fob.

CAUTION

Failure to observe the following safety instructions can result in an explosion, fire, damage to the key fob, electric shock and other injuries, as well as property damage:

- Do not pierce, break, crush, or cut the key fob or the battery.
- Do not expose the key fob or the battery to an open flame or extremely high temperatures.
- Do not expose the key fob or the battery to liquids or extremely low air pressure.
- Do not try to charge the key fob battery. It is not rechargeable.
- The key fob housing is made of plastic with sensitive electronic components and a CR2450 button cell battery. There is a risk of explosion if the battery is replaced with a battery other than a CR2450.
- The button cell battery that powers this device is considered hazardous and must be recycled or disposed of separately from household waste. Store the old battery in a safe place until it can be disposed of safely.

NOTICE

Do not drop the key fob. Doing so could damage the fob, including damage to the battery compartment allowing the button cell battery to fall out.

The remote entry key fob can be used to remotely unlock and lock the doors, start and end the pre-trip light check, and move down the door windows. See [Fig. 2.3](#).

- To unlock all doors, press the unlock button.
- To lock all doors, press the lock button.
- To start or end the pre-trip light check, press the lamp check button.

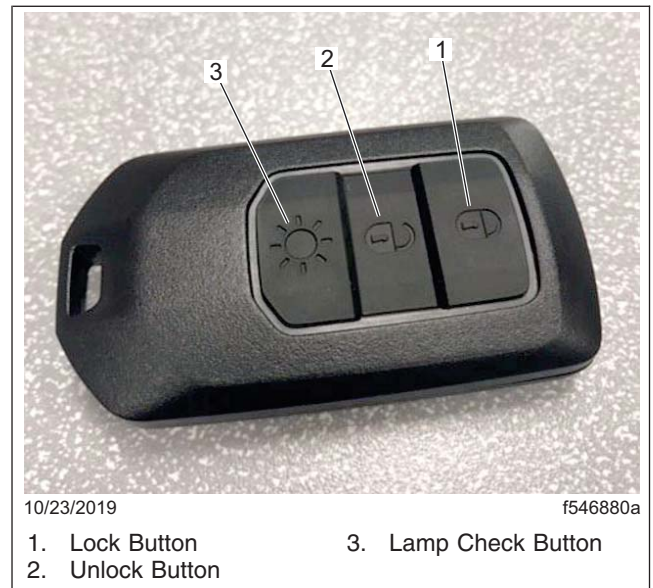

Fig. 2.3, Key Fob

- To move down the door windows, press the unlock button for three seconds.

Key Fob Programming

A maximum of four fobs can be programmed to work on one vehicle.

Whenever a new fob is needed, all existing fobs must be reprogrammed. Any existing fobs that were previously programmed will no longer work unless reprogrammed.

To have the key fobs programmed, take the vehicle to an authorized Freightliner dealer or service facility.

Specifications

The key fob uses a radio frequency link for communication between the fob and the vehicle.

Grab Handles and Access Steps

CAUTION

Slipping or falling from the vehicle can result in personal injury or property damage.

Always maintain three-point contact with the vehicle when entering or exiting the cab. Three-point contact means both feet and one hand, or both hands and one foot.

Vehicle Access

Wet or dirty shoes greatly increase the chance of slipping or falling. If your shoes are wet or dirty, be especially careful when entering or exiting the vehicle.

When steps are mounted on battery box covers, make sure that the cover is latched and secure before using the steps.

Do not step on the fuel tank, battery box, frame, etc., unless adequate slip resistant surfaces and handholds are provided.

Be careful not to get hands or feet tangled in hoses or other back-of-cab equipment as it could cause a trip and fall.

For ease of entry and exit, there are grab handles on the inner B-pillar, and optional grab handles on the A-pillars. In addition, the inner door grab handle and steering wheel may be used to provide a secure handhold. One or two access steps provide secure footholds.

The grab handles, access steps, and steering wheel are all part of the cab access system. Use these when getting into or out of the cab.

Cab Entry and Exit

Use the cab access system (grab handles, access steps, and steering wheel) to enter or exit the cab. See [Fig. 2.4](#) and [Fig. 2.5](#).

Entering from the Driver's Side

To enter the cab from the driver's side:

1. Open the driver's door and place anything that you are carrying in the cab.
2. Grasp the door-panel-integrated grab handle with your left hand, and the B-pillar with your right hand, or grasp the B-pillar grab handle with both hands. Reach up as far as is comfortable.
3. Place a foot on the step and pull yourself up. Shift your grasp on the B-pillar grab handle higher. If there is a second step, place the opposite foot on it and pull yourself up again.
4. Grasp the steering wheel with your left hand and step into the cab.

Exiting from the Driver's Side

To exit the cab from the driver's side:

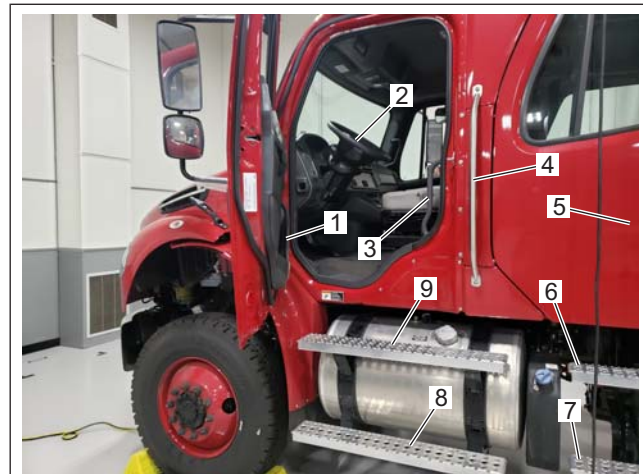

01/31/2023

f602955

1. Door-Panel-Integrated Grab Handle
2. Steering Wheel
3. B-Pillar Grab Handle
4. Exterior Grab Handle, Front
5. Exterior Grab Handle, Back (not shown)
6. Top Step, Back
7. Bottom Step, Back
8. Bottom Step, Front
9. Top Step, Front

Fig. 2.4, Cab Access System, Driver's Side (crew cab shown)

CAUTION

Always face in when exiting the cab. Do not attempt to exit with your back to the cab as you would going down a flight of stairs. It is easier to slip or lose your balance when exiting this way, and there is a greater likelihood of personal injury.

1. Place any items you wish to take in an accessible location on the seat or cab floor and make sure they will not get in your way as you exit.
2. Facing inward, grasp the steering wheel with your left hand and the B-pillar grab handle with your right hand.
3. Place your left foot on the top step.
4. Move your left hand to the door panel integrated grab handle, and your right hand lower down the B-pillar grab handle.
5. Move your right foot onto the step.



Fig. 2.5, Cab Access System, Passenger's Side (crew cab shown)

6. Step to the second step or ground with your left foot first, sliding your grasp down the grab handle. If there is another step down, place your right foot down first and then your left.
7. Release the grab handles or other handholds.
8. Retrieve any items from the cab that you wish to take with you.

Entering from the Passenger's Side

To enter the cab from the passenger's side:

1. Open the passenger's door, and place anything that you are carrying into the cab.
2. Facing the cab, grasp the B-pillar grab handle with your left hand and the door panel integrated grab handle with your right hand.
3. Step up on the bottom step with your left foot and pull yourself up.
4. Grasp the grab handles higher up.
5. Step up to the next step or the cab with your right foot.

6. Move your right hand to the A-pillar grab handle.
7. Move your left hand up the B-pillar grab handle.
8. Step into the cab.

Exiting from the Passenger's Side

To exit the cab from the passenger's side:



Always face in when exiting the cab. Do not attempt to exit with your back to the cab as you would going down a flight of stairs. It is easier to slip or lose your balance when exiting in this way and there is a greater likelihood of personal injury.

1. If you wish to take any items with you, place them in an accessible location on the seat or cab floor and make sure they will not get in your way as you exit.
2. While standing up from the seat facing inward, grasp the A-pillar grab handle with both hands, then place your right foot on the step.
3. Move your left hand to the B-pillar grab handle, and your right hand to the door panel integrated grab handle.
4. Place your left foot on the step.
5. Step to the second step or ground with your left foot first, sliding your grasp down the grab handles. If there is another step down, place your right foot down first and then your left.
6. Release the grab handles or other handholds.
7. Retrieve any items from the cab that you wish to take with you.

Back-of-Cab Access

When trailer air and electrical connections cannot be reached conveniently from the ground, Federal Motor Carrier Safety Regulations require commercial carriers to provide back-of-cab access.

Optional grab handles are mounted on each cab sidewall, on the left sidewall only, or on the cab back wall. See [Fig. 2.6](#). Steps are mounted either on the fuel tank(s) or on metal brackets. When a deck plate is necessary, it is mounted across the top of the frame rails.

Vehicle Access

IMPORTANT: Climb onto, and down from, back-of-cab access facing in toward the vehicle, as you would on a ladder. Do not climb up or down facing out away from the vehicle.



Fig. 2.6, Back-of-Cab Access Supports (typical)

CAUTION

Wet or dirty shoe soles greatly increase the chance of slipping or falling. If your soles are wet or dirty, be especially careful when climbing onto, or leaving, the back-of-cab area.

Always maintain three-point contact with the back-of-cab access supports while entering and exiting the back-of-cab area. Three-point contact means both feet and one hand, or both hands and one foot, on the grab handles, steps, and deck plates. Other areas are not meant to support back-of-cab access, and grabbing or stepping in the wrong place could lead to a fall and personal injury.

Be careful not to get hands or feet tangled in hoses or other back-of-cab equipment. Doing so could cause a trip and fall with possible injury.

Climbing Up to the Back-of-Cab

When climbing onto the deck plate, do the following:

1. Grasp the sidewall grab handle with both hands. Reach up as far as is comfortable.
2. Place one foot on the bottom step and pull yourself up.
3. Place your other foot on the top step.
4. Move your lower hand to a higher position on the grab handle.
5. Step onto the deck plate.

Climbing Down from the Back-of-Cab

To climb down from the back-of-cab area:

1. Grasp the sidewall grab handle with both hands.
2. Step one foot at a time onto the top step.
3. Move your upper hand to a lower position on the grab handle.
4. Move one foot to the bottom step.
5. Move your upper hand to a lower position on the grab handle.
6. Step to the ground with your upper foot first.

Hood Opening and Closing

The hood can be raised to a full-open position. A torsion bar helps you to raise the hood, and to lower it to the operating position. Hood restraint cables prevent the hood from overtravel. A hood damper limits the closing speed. In the operating position, the hood is secured to the cab-mounted half-fenders by a hold-down latch on each side of the hood.

To Open the Hood

1. Apply the parking brakes.
2. Release both hood hold-down latches by pulling the ends outward. See [Fig. 2.7](#).

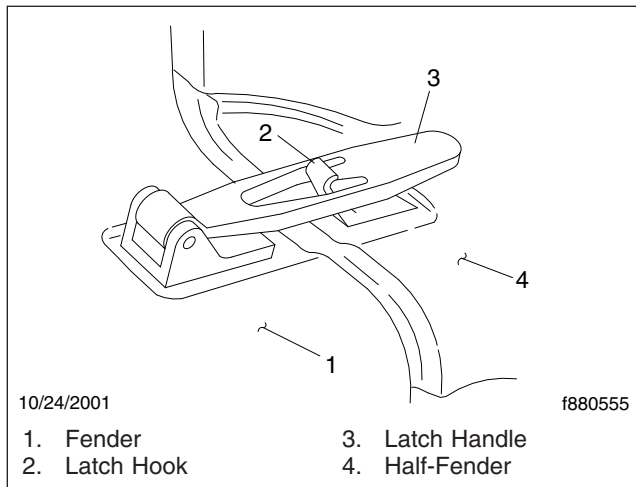

Fig. 2.7, Hood Hold-Down Latch

CAUTION

Do not let the hood free-fall to the full-open position. To do so could cause damage to the hood or hood straps.

3. Standing in front of the hood, raise the rear of the hood upward until it reaches the over-center position (45 degrees from vertical). Then slowly bring it to a stop.

To Close the Hood

1. Push the hood over center.
2. As the hood goes over center, the damper automatically slows its rate of descent. If needed, you can also slow its rate of descent with your hand.
3. Make sure the hood is flush with the cowl, then secure the hood by engaging both hood hold-down latches.

IMPORTANT: Make sure that both hold-down latches are fully engaged before operating the vehicle.

3

Instruments

Instrumentation Control Unit: ICUC	3.1
Driver Display Overview: ICUC	3.3
Digital Gauges and System Monitors: ICUC	3.11
Infotainment: ICUC	3.16
Analog Instruments	3.18
Overhead Instrument Panel	3.24
Warnings, Indicators, and Messages	3.24

Instruments

Instrumentation Control Unit: ICUC

The instrumentation control unit (ICU) provides the driver with engine and vehicle information. An M2 Plus vehicle will be equipped with an ICUC. See [Fig. 3.1](#) for a typical ICUC layout.

This section provides general system and operating instructions for ICUC components. Following sections provide more detailed information.

Ignition Sequence

When the ignition is turned on, the ICU runs a self-check. Observing the ignition sequence is a good way to ensure the ICU is functioning properly.

IMPORTANT: Do not crank the engine until the ICUC self-check is complete.

ICUC

NOTE: Air gauges in the ICUC do not complete

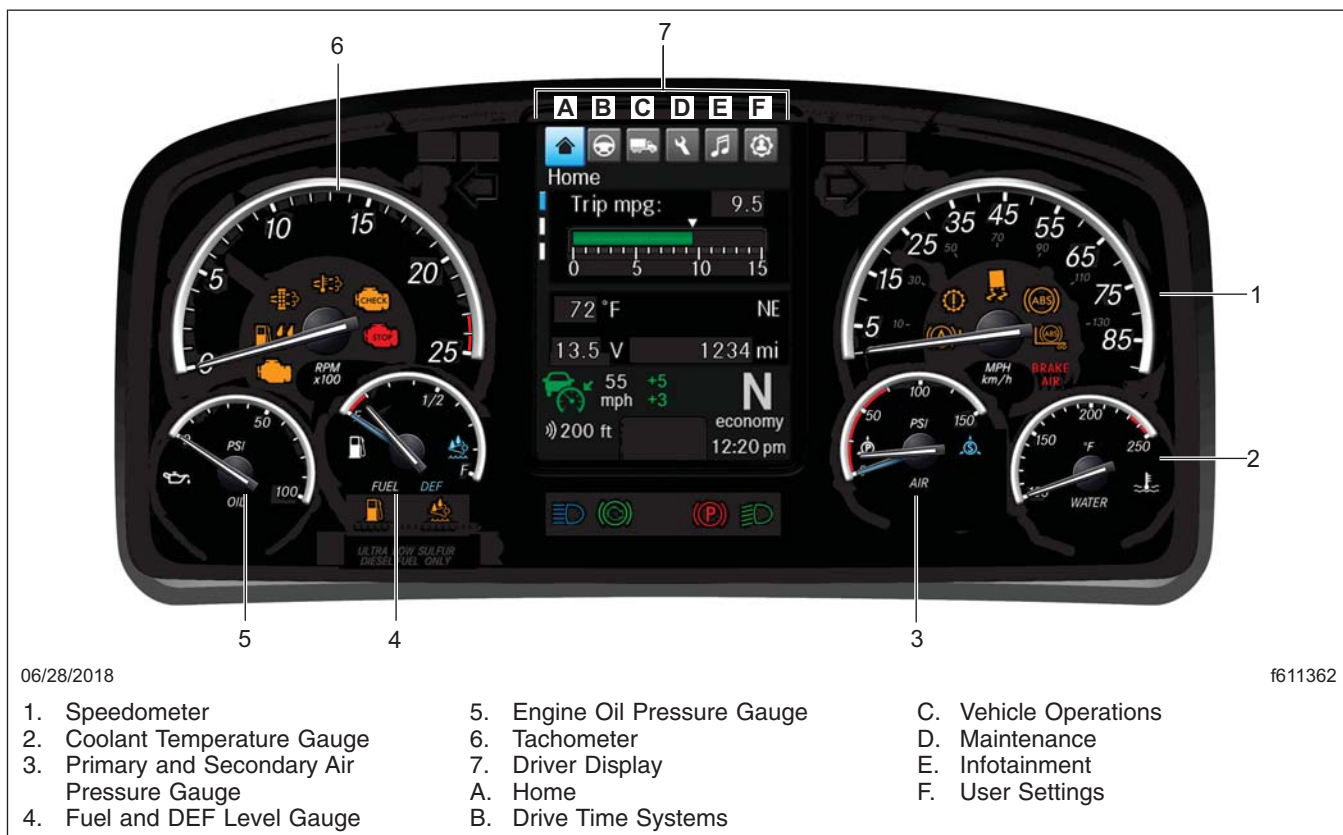

Fig. 3.1, Instrument Cluster Overview - ICUC

ICUC

The instrument cluster unit is comprised of six physical gauges, indicator lamps (telltales), a six inch portrait driver display screen, steering wheel mounted switches, and audible warning systems. Warning and indicator lamps illuminate in red (warning), amber (caution), green (status on), or blue (informational).

The driver display screen provides information on various vehicle systems as well as warnings, cautions, and notifications on systems status.

a sweep of their dials during the ignition sequence.

When the ignition is turned on, the following actions should occur in the ICUC:

- Freightliner and engine logo displays on the driver display until startup is complete
- Speedometer and tachometer complete a full sweep of their dials
- Warning and indicator lamps illuminate, then are extinguished (if not active)

- Audible alert sounds for any active faults
- Active alerts are displayed on the ICUC screen.

If the ICUC receives active fault codes, it displays them one after the other until the ignition is turned off. The alerts are displayed until they are acknowledged. If there are no active faults, the ICUC displays the home screen after the self-check completes.

IMPORTANT: If any red or amber warning and indicator lamps do not illuminate during the ICUC self-check or do not go out (if not active) after the self-check completes, take the vehicle to an authorized Freightliner service facility as soon as possible.

If active faults are present, take the action outlined in "Warnings, Indicators, and Messages" tables in this chapter, then take the vehicle to an authorized Freightliner service facility as soon as possible.

ICUC Screen Navigation

In the ICUC, the driver display screen is broken up into three areas as shown in **Fig. 3.2**: a navigable menu at the top of the screen, a static display at the bottom of the screen, and the central display area (with screen indicator dashes to communicate how many display screens are available in the current menu category).

NOTE: To adjust the brightness of ICUC screen go to User Settings.

The ICUC top level menu categories, shown in **Fig. 3.1**, allow a driver to quickly carry out common actions. Top level menu categories are Home, Drive Time Systems, Vehicle Operations, Maintenance, Infotainment, and User Settings.

The static menu display at the bottom of the screen, shown in **Fig. 3.3**, displays the current vehicle speed, transmission gear, cruise control information, a clock, and active telltales.

ICUC Steering Wheel Switch Pods

To navigate the ICUC menus, use the 'Menu Right' and 'Menu Left' arrows on the left-hand steering wheel switch pod, shown in **Fig. 3.4**, to move between the top-level menus. Use the 'Menu Up' and 'Menu Down' buttons to move from screen to screen within the selected category.

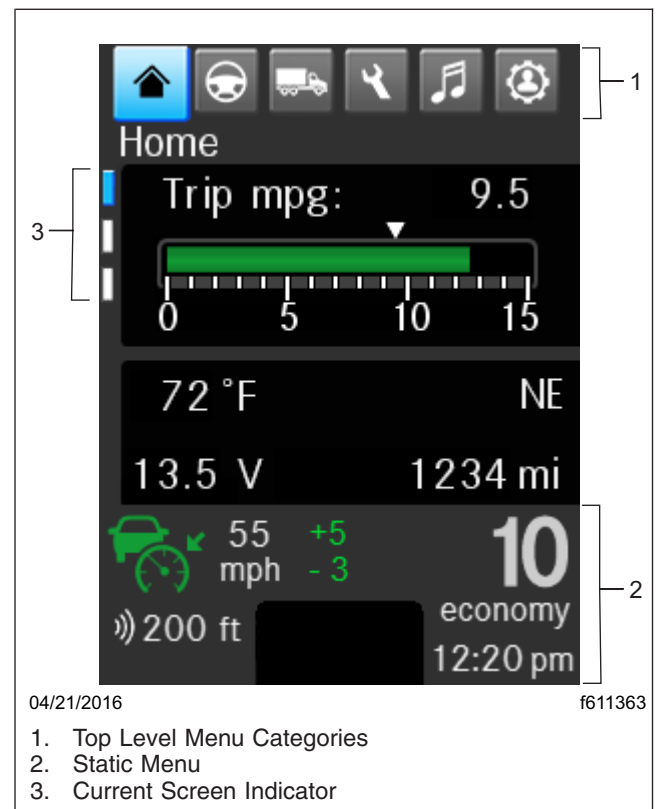

Fig. 3.2, ICUC Driver Display

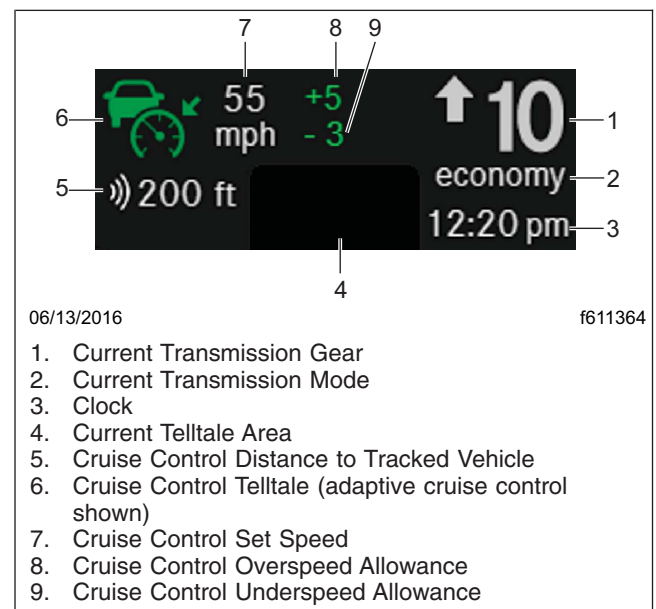

Fig. 3.3, ICUC Static Display

For Quick Access Systems menus press the Quick Access System Settings button in the right-hand

Instruments



Fig. 3.4, ICUC Steering Wheel Switches

switch pod. If Quick Access Systems menus are not available, the button will bring up the home screen.

Driver Display Overview: ICUC ICUC Alert Messages

Alert messages include warnings, cautions, and notices that require the driver's attention. The header text and color indicates the priority of the on-screen message, listed from the highest to the lowest:

- Warning (red)
- Caution (amber)
- Informational (blue, green, white, and grey)

Warnings alert the driver to situations or conditions that may pose a threat to control of the vehicle. Follow all instructions given in the message.

Cautions alert the driver to situations or conditions that may result in damage to vehicle components or a derating of engine power.

Informational notices alert the driver to situations or conditions that may affect vehicle performance.

See [Fig. 3.5](#) for typical alert messages.

Watch for Ice Alert

When ambient air temperature drops below 34°F (1°C), a Watch For ICE caution, as shown in [Fig. 3.6](#), will appear. To acknowledge and dismiss the caution message, press the back button in the left-hand steering wheel switch pod. A 34°F (1°C) temperature will also trigger the appearance of a snowflake telltale next to the temperature display. The snowflake telltale will display until the ambient air temperature rises to 37°F (3°C).

If the temperature drops below 34°F (1°C) after rising above 37°F (3°C), the Watch For ICE popup and snowflake will reappear.

ICUC Time and Alarm Settings

Time and date are set automatically when the vehicle is equipped with a tachograph. When a vehicle is equipped with a tachograph only the time zone can be changed.

The correct time and date is required for the following ICU functions to work:

- alarm clock,
- predictive maintenance intervals,

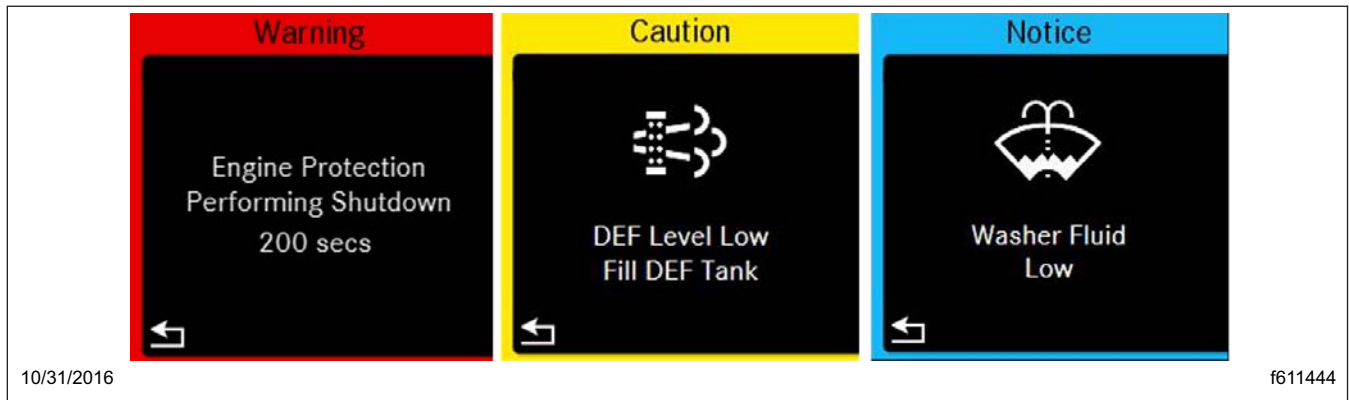

Fig. 3.5, Sample Alert Messages

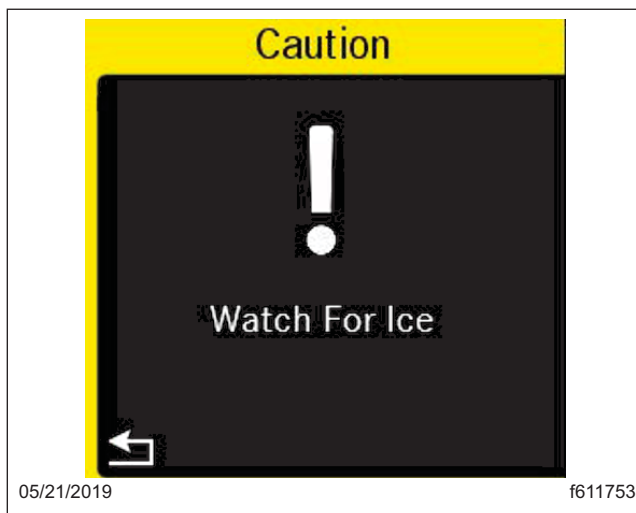

Fig. 3.6, ICUC Watch for Ice Popup

- prognostics.

Time Settings: Display Format

NOTE: Local time offsets can also be viewed under this menu.

In the ICUC, time can be displayed in 12 or 24 hour format. Time format is set under Time Settings under User Settings.

1. Select the gear icon to open the 'User Settings' menu. The last settings menu accessed will open.
2. If not on the 'Settings Options List' screen, use the up arrow in the left-hand steering wheel switch pod to move to this screen.
3. Press 'OK' to access the settings menus.

4. Use the down arrow in the left-hand steering wheel switch pod to get to 'Time.'
5. Press 'OK' to access Time.
6. Use the right arrow to switch between 12h and 24h.
7. Press 'OK' on the left-hand steering wheel switch pod to choose an option.

Setting An Alarm

In the ICUC, one alarm can be set under Alarms under the User Settings, as shown in Fig. 3.7.

The alarm triggers a repeated chirping sound as well as a alarm pop-up. Both can be dismissed by pressing the back button on the left hand steering wheel switch pod.

1. Select the gear icon to open the 'User Settings' menu. The last settings menu accessed will open.
2. If not on the 'Alarms' screen, use the down arrow in the left-hand steering wheel switch pod to move to this screen.
3. Press 'OK' to access the alarm clock options.
4. Use the up and down arrow to choose hour, minute, am/pm and alarm status.
5. Press 'OK' to set the alarm.

Main ICUC Driver Display Screens

NOTE: Screens will vary depending on vehicle options. Some screens are accessible only when the vehicle is parked and the parking brake is on.

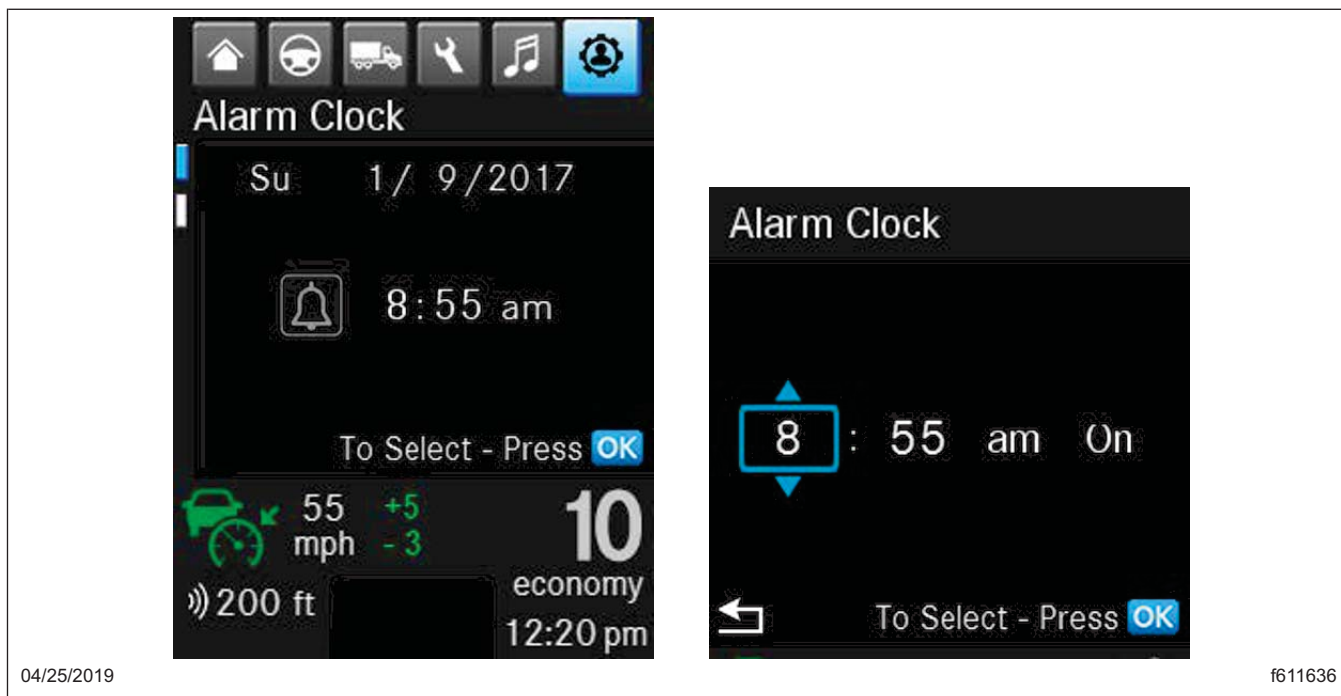

Fig. 3.7, ICUC Alarm Clock Screens

The main ICUC driver display screens include the splash screen that displays during vehicle start-up and the cruise control settings screen.

The six ICUC top-level menu categories are:

- Home/Basic Information
- Drive Time Systems
- Vehicle Operations
- Maintenance
- Infotainment
- User Settings

Home/Basic Information Screens

There are three screens under Home/Basic Information:

- Home
- Trip
- Leg

The 'Home' screen displays a fuel consumption bar graph, the current outside temperature, the vehicle charging system voltage, the compass direction of travel, and the current odometer value.

The 'Trip' report screen, shown in [Fig. 3.9](#), displays calculations based on the engine run time such as overall mileage of trip, trip mpg, average mph, and trip time. The 'Leg' report screen does the same for the current leg of the trip. To reset either screen, press and hold the 'OK' switch on the switch pod when on the screen.

Drive Time Systems Screens

There are four screen under Drive Time Systems:

- Speed
- Driving Assistance
- Video

The 'Speed' screen, shown in [Fig. 3.8](#), displays the current vehicle speed and PasSmart information.

Depending on equipment installed, the 'Driving Assistance' screen, shown in [Fig. 3.10](#), displays cruise control information, lane departure information, side guard assist information, and display's the current traffic signs.

Depending on systems installed, video is recorded when active safety systems are engaged or unsafe driving conditions are detected.

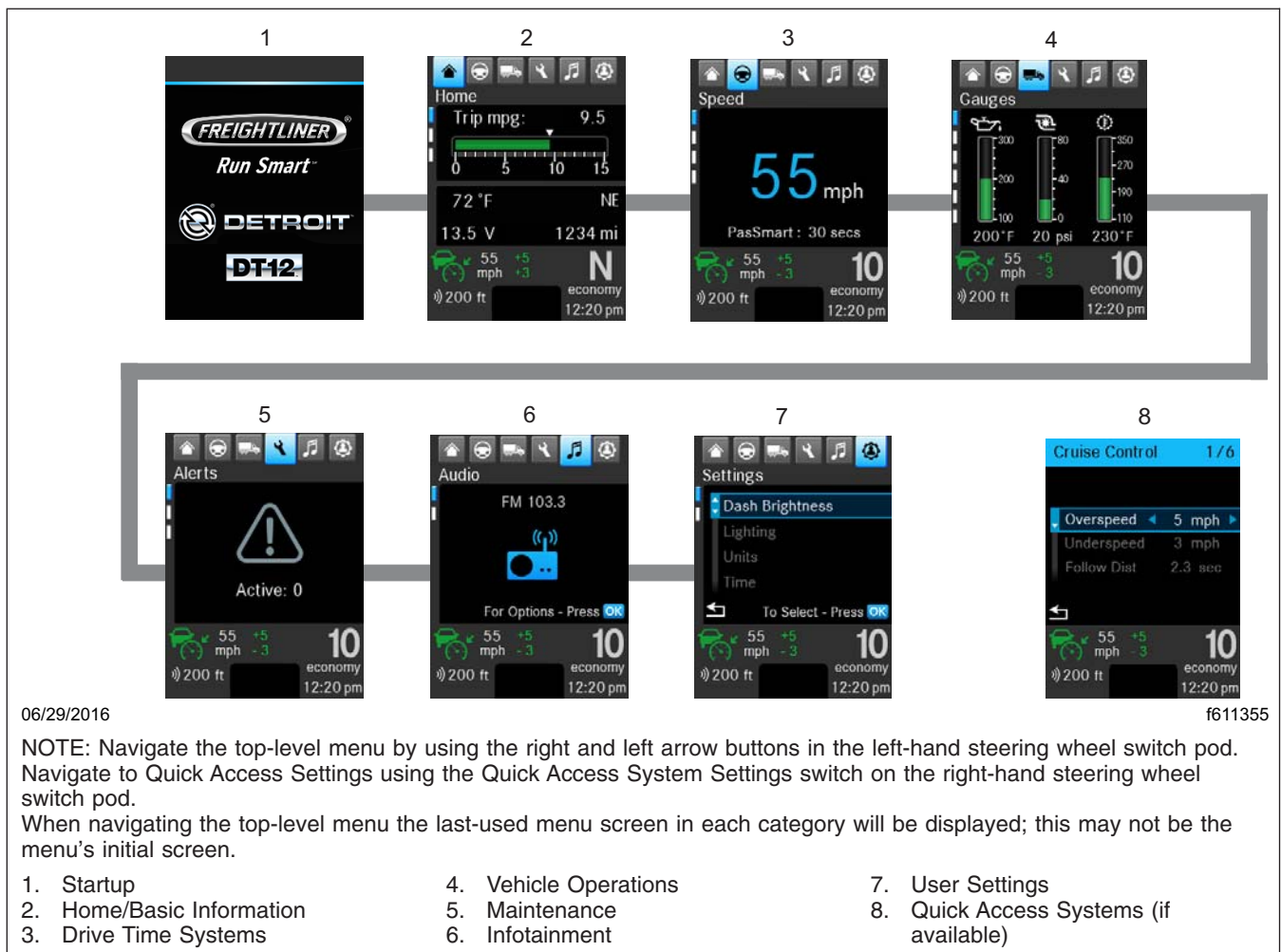

Fig. 3.8, ICUC Top-Level Menu Initial Screens

Vehicle Operations Screens

There are five possible options under 'Vehicle Operations':

- Gauges
- Diesel Particulate Filter
- Tire Pressure Monitoring
- Locks
- Vehicle Settings

For information on the display's for gauges and, if equipped, tire pressure monitoring see the "Instruments and Systems" section in this chapter. Information on diesel particulate filter monitoring is covered in chapter [Chapter 13 Emissions](#). If equipped, information on 'Transmission Prognostics'

is covered in [Chapter 14 Automated and Automatic Transmissions](#). For information on Locks see [Chapter 16 Drive Axles](#).

The Vehicle Settings screen, shown in [Fig. 3.11](#), provides access to settings for vehicle systems such as cruise control, engine idle adjust, and the transmission.

ICUC Maintenance Screens

The maintenance screens are used to retrieve fault codes and other diagnostic and service information pertaining to the vehicle.

There are five menu options under Maintenance:

- Alerts
- Diagnostics

Instruments



Fig. 3.9, Basic Information: Trip Report



Fig. 3.11, Vehicle Operations: Vehicle Settings



Fig. 3.10, Drive Time Systems: Driver Assistance

- Engine Maintenance
- Transmission Prognostics

- Maintenance System

The 'Alerts' screen, shown in Fig. 3.12, gives access to all active notices, cautions, and warnings.

Fault codes are color-coded to indicate the severity of the fault. Red indicates a condition that may pose a threat to control of the vehicle. Amber indicates a condition that may result in damage to vehicle components or the derating of engine power. Blue, grey, and green are used to indicate information on a component's status.

The 'Diagnostics' screen, shown in Fig. 3.13, displays active diagnostic trouble codes and available software updates.

The 'Engine Maintenance' screen, shown in Fig. 3.14, displays the current engine hours.

The 'Maintenance System' screens give information about when maintenance is required. See the "Instruments and Systems: ICUC" in this chapter for more details.

ICUC User Settings Screens

The ICUC Setting Options List screens, shown in Fig. 3.15, allow the driver to choose the following:

- Dash Brightness



Fig. 3.12, Maintenance: Alerts



Fig. 3.14, Maintenance: Engine Maintenance



Fig. 3.13, Maintenance: Diagnostics

- Lighting Settings
- Units Settings

- Time Settings
- Gauge Settings
- Key Alert Settings
- Language Settings
- Safety System Settings

Dash Brightness allows for setting the brightness of the dashboard display.

Lighting Settings controls if the courtesy and entrance lights are on and how long they stay on.

Unit Settings controls the measurement values for speed, distance traveled, temperature, pressure, and following distance.

Time Settings controls the time display format (12h/24h) and local time zone offsets.

Gauge Settings allow the driver to change the order in which gauges are displayed on the gauge screens.

Key Alert Settings control if the key alerts is on or off.

Language Settings allow the driver to set the ICU language to be in either English (American), Spanish (Mexican), or French (Canadian).

Safety System Settings allow the driver to turn safety features such as Attention Assist, Traffic Sign

Instruments

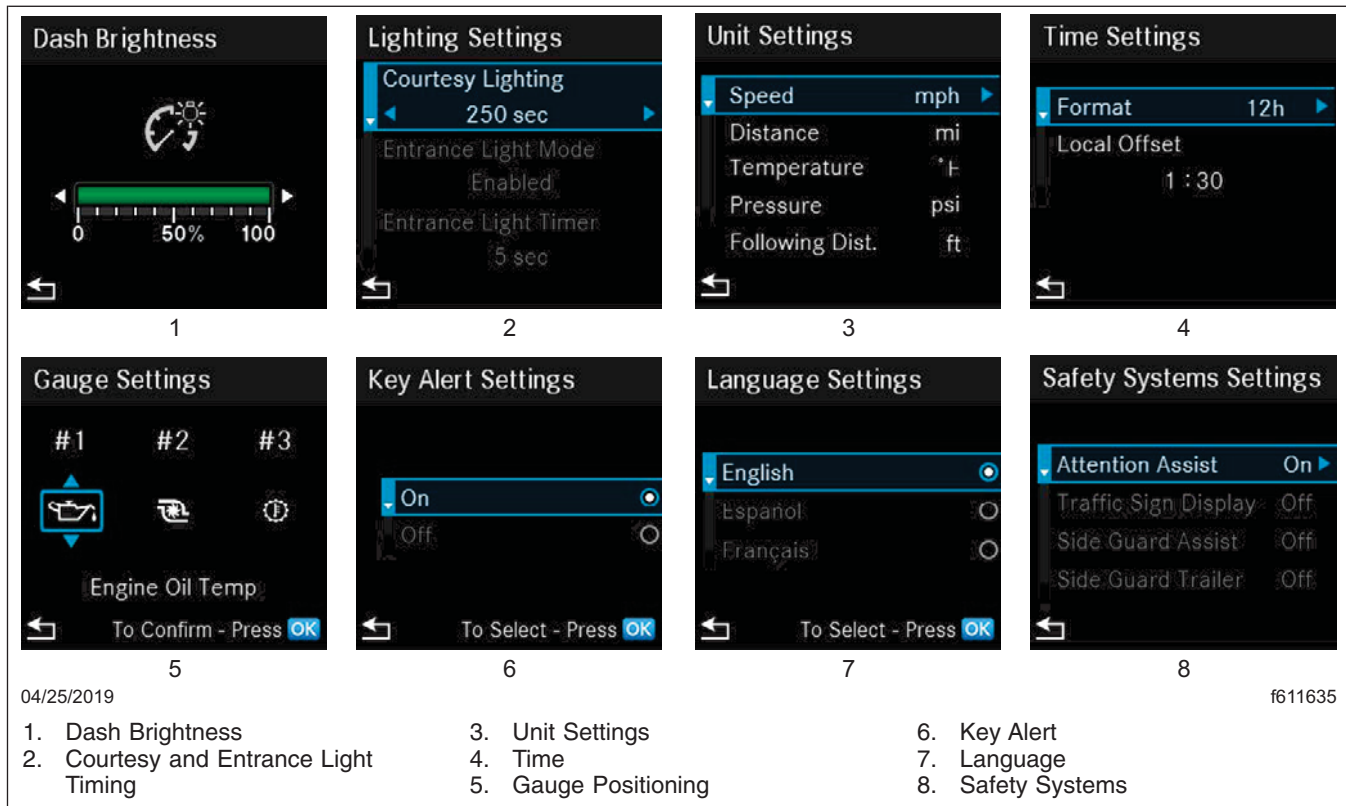

Fig. 3.15, ICUC User Settings Screens

Display, Side Guard Assist, and Side Guard Trailer on or off.

ICUC Quick Access Systems Screens

Quick Access Screens are activated by a button on the right hand steering wheel pod. There are up to six top-level menu options:

- Hysteresis
- Cruise Control
- Transmission
- Engine Idle Adjust
- Power Take Off
- Optimized Idle

Hysteresis allows the driver to set the overspeed and underspeed in mph (km/h). See [Fig. 3.16](#).

Cruise Control allows the driver to control such features as active lane assist, lane position, and following distance. See [Fig. 3.17](#). For more information see "Instruments and Systems: ICUC" in this chapter.

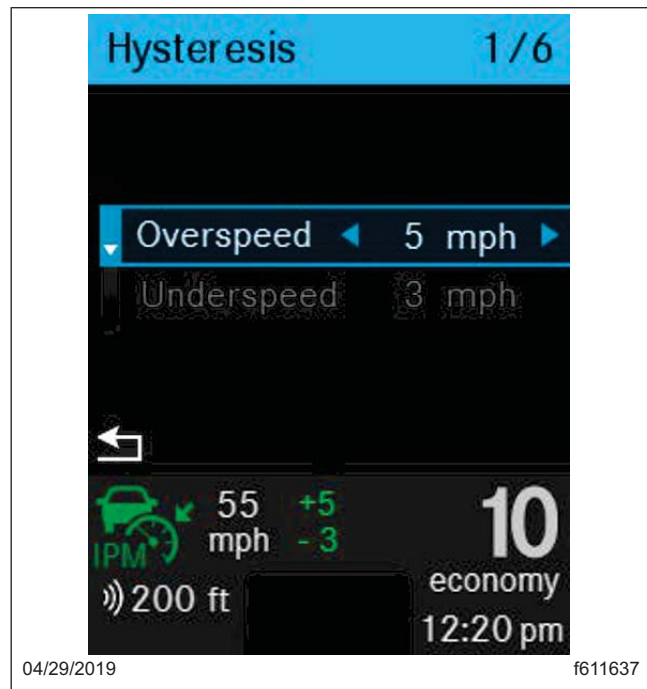

Fig. 3.16, Quick Access Screen: Hysteresis

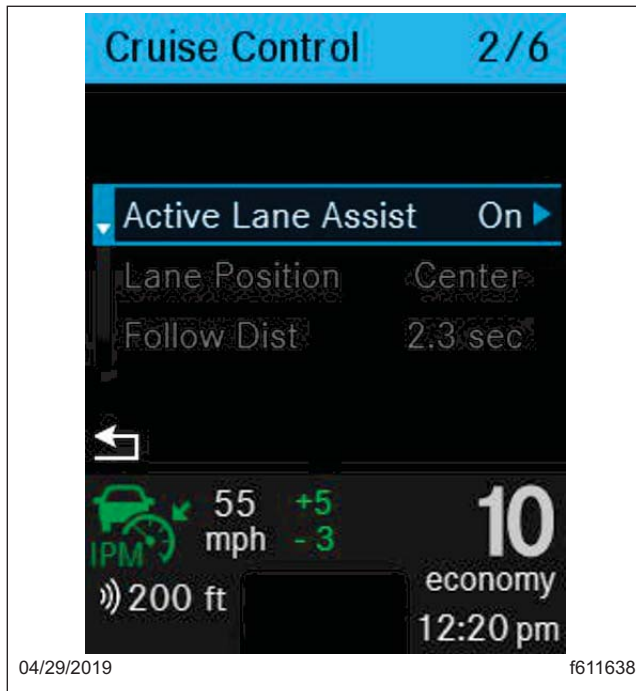

Fig. 3.17, Quick Access Screen: Cruise Control



Fig. 3.18, Quick Access Screen: Transmission

Transmission allows the driver to turn the creep mode or eCoast feature on or off. See Fig. 3.18. See "Instruments and Systems: ICUC" in this chapter for more information.

Engine Idle Adjust allows the driver to adjust or deactivate the engine idle. It is not available when the vehicle is in motion. See Fig. 3.19. For more information see "Instruments and Systems: ICUC" in this chapter.

Power Take Off allows the driver to customize the amount of power being transferred. See Fig. 3.20.

The Optimized Idle screens allow the driver to choose the optimized idle mode and enable or disable the feature. For more information see "Instruments and Systems: ICUC" in this chapter

Software Updates

A software update consists of three steps:

1. Downloading the software.
2. Installing the software.
3. Activating the software by restarting the system.

A popup message will appear when an update is available. In addition, the software update option in the diagnostics menu will be active.

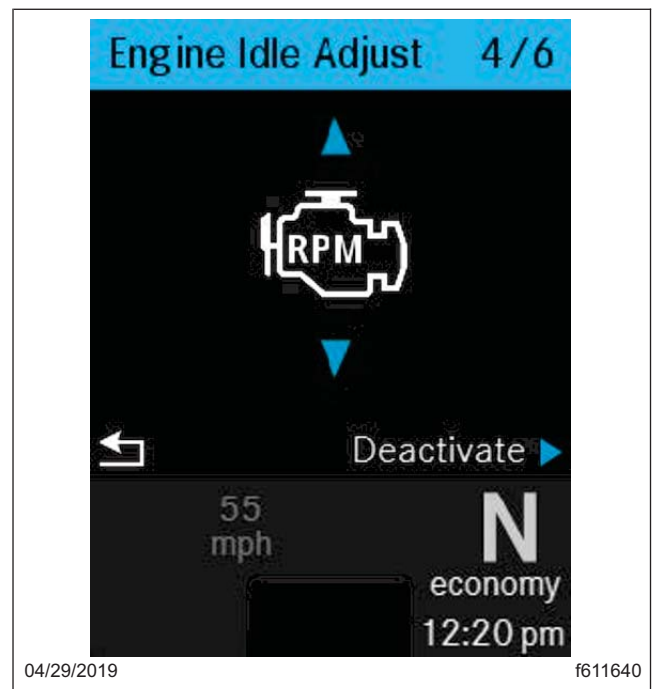

Fig. 3.19, Quick Access Screen: Engine Idle Adjust

The vehicle must be in neutral gear, the parking brake set, and the engine off before a software



Fig. 3.20, Quick Access Screen: Power Take Off (PTO)

update can start. Once started, a software update cannot be cancelled.

During the software update process, progress messages will be provided. See Fig. 3.21 for typical ICUC software update screens.

If a software update is interrupted, the system will ask if you want to restart the process or inform you that the vehicle cannot be driven until the update is complete. If a software update fails, the system will attempt to revert to the previous version. A notification will appear when a software update has been successfully installed.

Failure to install software updates may make data less secure and/or mean vehicle systems are not operating at their best.

NOTE: An estimation of installation time will be given before the software update starts. Installation can take several minutes. During installation individual functions and controls will not be available or only available to a limited degree.

Digital Gauges and System Monitors: ICUC

ICUC Gauges

In the ICUC there are six digital gauges and system screens for the Diesel Particulate Filter (DPF) and Tire Pressure Monitoring System (TPMS).

The six digital gauges under the Vehicle Operations menu of the driver display are:

- Engine Oil Temperature
- Turbo Boost Pressure
- Transmission Oil Temperature
- Front Axle Oil Temperature
- Rear Axle Oil Temperature
- Application Air Pressure

In the ICUC, if a value measured by a digital gauge exceeds the normal range, an amber caution or red danger popup message will appear. However the bar graph color will remain green and the bar graph icons will remain white.

NOTE: The order of ICUC digital gauges and therefore the screen on which they display can be changed under Gauge Settings under Settings.

Engine Oil Temperature Gauge

NOTICE

A sudden increase in oil temperature that is not caused by a load increase may indicate mechanical failure. Bring the vehicle to a safe stop and investigate the cause to prevent further damage. Do not operate the engine until the cause has been determined and corrected.

During normal operation, the optional engine oil temperature gauge, shown in Fig. 3.22, should read in the following temperature range:

- 200 to 260°F (93 to 126°C) for Detroit and Cummins engines

Under heavy loads, such as when climbing steep grades, temperatures that exceed the normal oil temperature range for a short period are not unusual. If the temperature returns to normal when the load decreases, there is no problem.

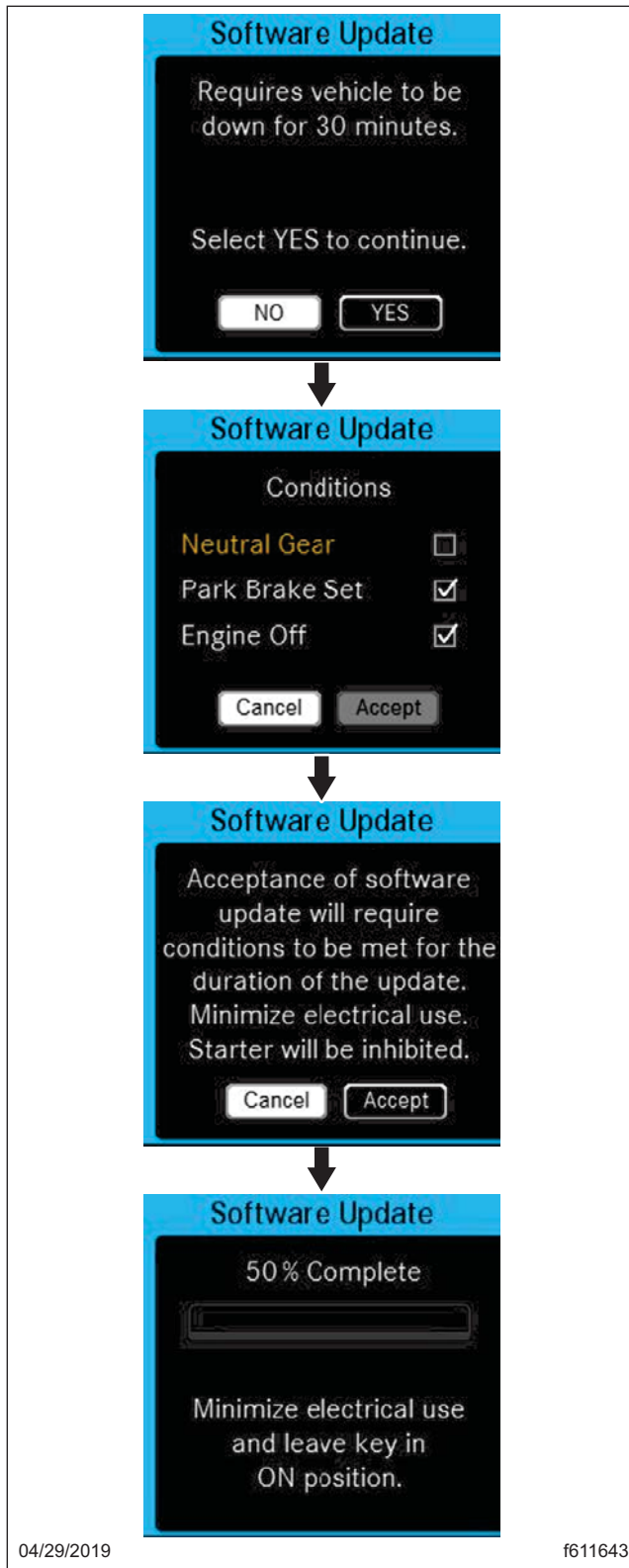

Fig. 3.21, Example ICUC Software Update Screens

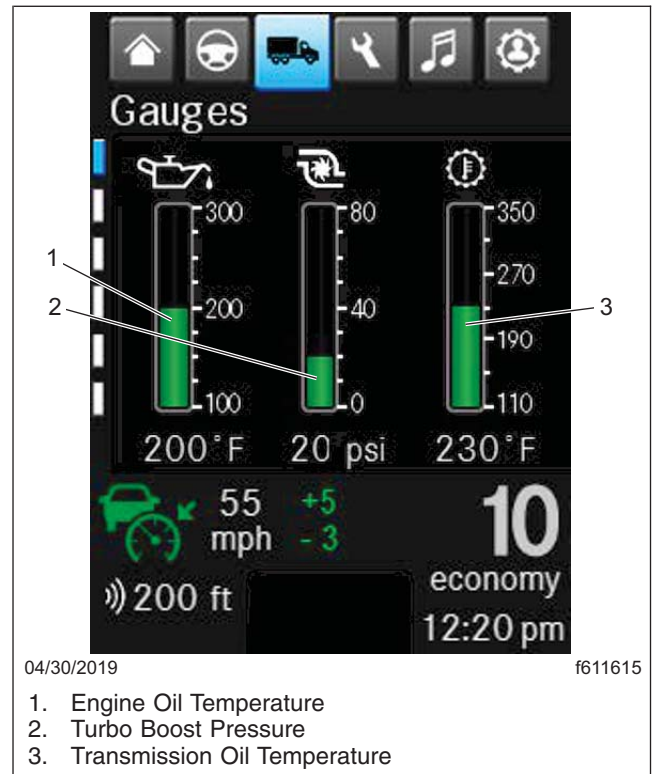

Fig. 3.22, Digital Engine Oil, Turbo Boost Pressure, and Transmission Oil Temperature Gauges - ICUC

Turbocharger Boost Pressure Gauge

The turbocharger boost pressure gauge, shown in Fig. 3.22, indicates the pressure in the intake manifold, in excess of atmospheric pressure, being created by the turbocharger.

Transmission Oil Temperature Gauge

The transmission oil temperature gauge, shown in Fig. 3.22, measures the transmission lubricant operating temperature. Temperatures vary by application, but the transmission fluid temperature gauge reading should not exceed 250°F (121°C).

NOTICE

A sudden increase in transmission fluid temperature that is not caused by a load increase may indicate mechanical failure. Bring the vehicle to a safe stop and investigate the cause to prevent further damage. Do not operate the vehicle until the cause has been determined and corrected.

Instruments

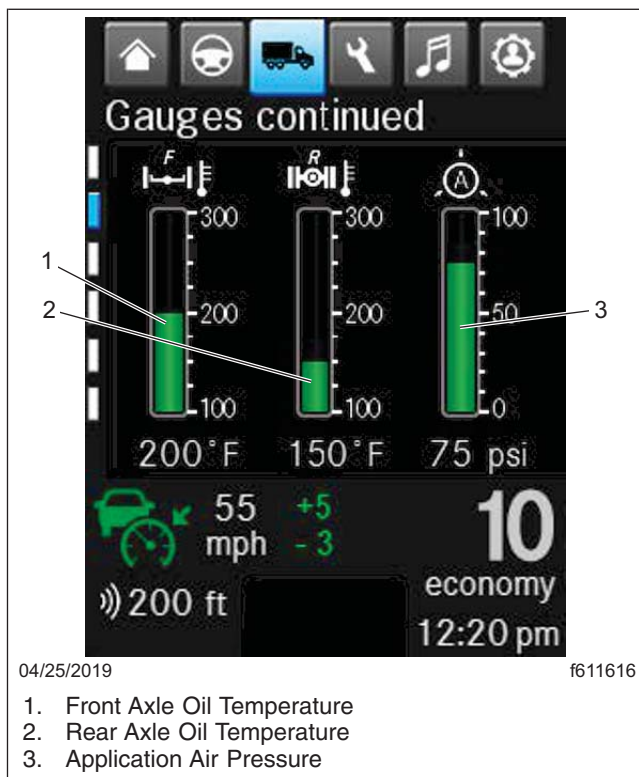

Fig. 3.23, Digital Front and Rear Axle Temperature, and Application Air Pressure Gauges - ICUC

Under heavy loads, such as when climbing steep grades, temperatures that exceed the normal oil temperature range for a short period are not unusual. If the temperature returns to normal when the load decreases, there is no problem.

Application Air Pressure Gauge

The application air pressure gauge shown in Fig. 3.23, registers the air pressure being used to apply the brakes. The gauge will not register air pressure until the foot brake pedal is depressed or the trailer hand brake is applied.

DEF and Diesel Particulate Filter Monitoring

See Chapter 13 Emissions for details of Diesel Particulate Filter and DEF level monitoring.

Tire Pressure Monitoring System

The Tire Pressure Monitoring System (TPMS) screens display tire pressure, temperature, and sensor battery status. See Fig. 3.24. Maintaining

correct tire pressure increases fuel economy. Sustained high tire temperature can cause a tire to deteriorate, leading to tread separation and blowouts.

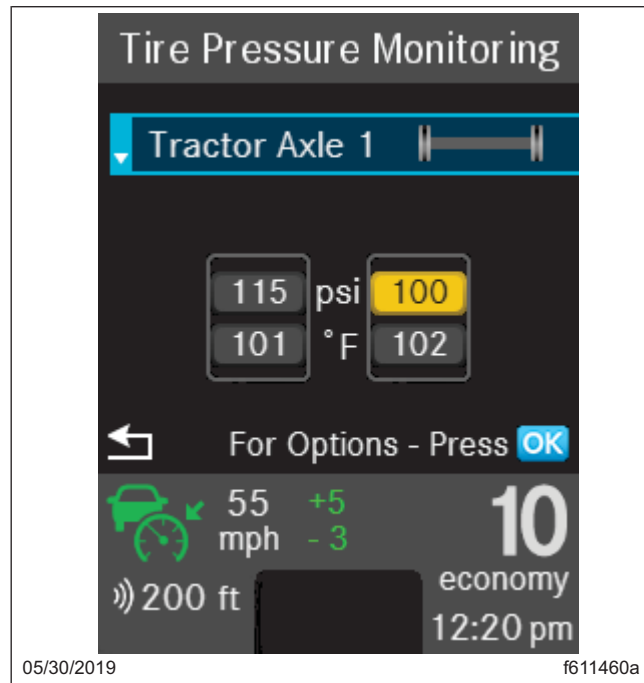

Fig. 3.24, Vehicle Operations: TPMS Axle Tire Pressure, Temperature, and Sensor Status

Tire pressure can be displayed in psi or bar units. Temperature can be displayed in °F or °C. Units of measure are set under Settings. Sensor battery status is displayed as a bar chart inside the outline of a battery.

The TPMS will change the color of the tire on the ICUC screen if the tire pressure or temperature is either too high or too low. See Fig. 3.24. It will also change the color of the sensor battery icon if the power levels are too low. Amber indicates a condition that may result in damage. Red indicates a condition that may pose a threat to the vehicle.

Tire pressure monitoring settings are part of the TPMS. Threshold temperatures and what triggers alerts can be set on this screen.

Other ICUC Gauges and Measurements

In addition to the two screens of gauges displayed under the Vehicle Operations menu described above, the ICUC driver display communicates a number of

values related to vehicle operations. They are listed in alphabetical order below.

Alerts

The Alerts screen stores the current active alerts.

Alerts are color-coded to indicate severity. Red indicates a condition that may pose a threat to control of the vehicle. Amber indicates a condition that may result in damage to vehicle components or derating of engine power. Grey is used for notices.

Battery Voltage

The Home screen in the ICU displays the vehicle charging system voltage in the bottom left. By monitoring this number, the driver can stay aware of potential battery charging problems and have them fixed before the batteries discharge enough to create starting difficulties.

The Home screen will normally show approximately 13.7 to 14.1 volts when the engine is running. The voltage of a fully charged battery is 12.7 to 12.8 volts when the engine is off. Battery voltage under 12.0 volts is considered a low battery, and a completely discharged battery will produce only about 11.0 volts.

If the Home screen shows an undercharged or overcharged condition for an extended period, have the charging system and batteries checked at an authorized Freightliner service facility.

Diagnostics

The Diagnostics screen communicates fault codes and other diagnostic information about the vehicle.

Fault codes are color-coded to indicate the severity of the fault. Red indicates a condition that may pose a threat to control of the vehicle. Amber indicates a condition that may result in damage to vehicle components or derating of engine power. Grey indicates a condition that may affect fuel efficiency or vehicle handling.

Engine Maintenance

Shows the number of hours the engine has been operating.

Maintenance System

NOTE: the wrench icon is indicative of service, not of something that needs to be fixed.

Standard messaging is based on the number of miles (km) driven or time passed since the last service.

Predictive maintenance information is calculated based on these factors as well as engine and transmission load and oil temperature.

Currently, predictive maintenance information is given for engine oil, transmission oil, and axle oil changes. By taking driving conditions into account, predictive maintenance provides more accurate intervals for fluid changes.

Just before the service interval ends, a message that maintenance is due will appear. See [Fig. 3.25](#).

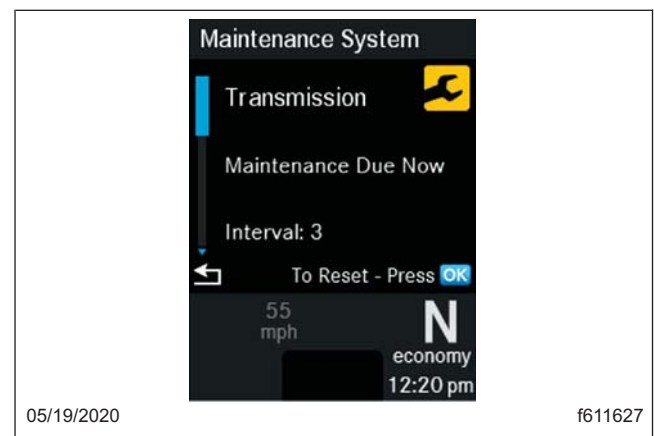

Fig. 3.25, Maintenance System Status - ICUC

When the service interval is reached, a pop-up notice that maintenance is due will appear with every key cycle.

When the service interval is overdue, the color of the wrench icon on the maintenance screen will change from white to amber and the message will change to Maintenance Overdue. This cautionary pop-up will continue to appear with every key cycle.

Each service interval must be reset in the maintenance system when service is performed to provide for accurate future service intervals and to turn off pop-up messaging.

The reset button for maintenance system screens will not appear until the vehicle has been driven 6.2 miles and the engine has run for fifteen minutes.

Maintenance system information and service recommendations can also be viewed in the [Detroit Connect](#) portal. Information on the portal is updated every seven days.

Instruments

Transmission Prognostics

The transmission prognostics screen is only available for Allison transmissions. It displays information on the transmission health status (oil filter status, oil level, and oil life). If transmission health falls below acceptable limits, a message will pop-up on the driver display.

NOTE: For a valid oil level measurement, the vehicle must be stopped on a level surface with the transmission in neutral (N).

Suspension Air Pressure

The ICUC may display four vehicle air suspension yellow caution alerts.

These include Suspension Lowered and Suspension Raised alerts indicating that the current rear suspension height is either below or above the normal ride height. See [Fig. 3.26](#) and [Fig. 3.27](#).

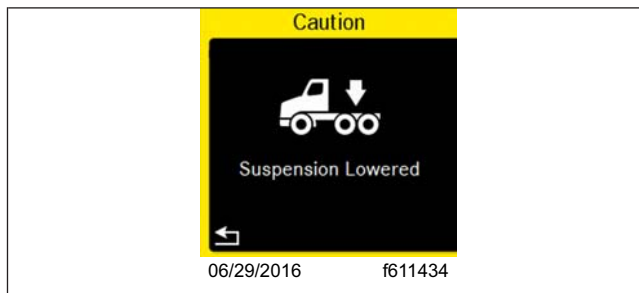

Fig. 3.26, Suspension Lowered Alert - ICUC

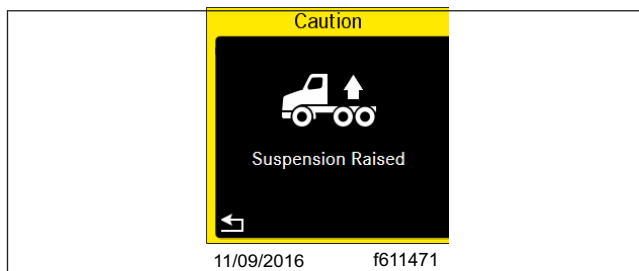

Fig. 3.27, Suspension Raised Alert - ICUC

The ECAS Problem Detected alert, shown in [Fig. 3.28](#), indicates the electronically controlled air suspension system has an active fault.

A flashing Load Transfer alert, as shown in [Fig. 3.29](#), indicates the ECAS system is applying the maximum available vehicle load on the drive axle up to the maximum allowable limit determined by the gross axle weight rating (GAWR). Load transfer mode

automatically deactivates when the vehicle reaches 45 mph (72 kmh).

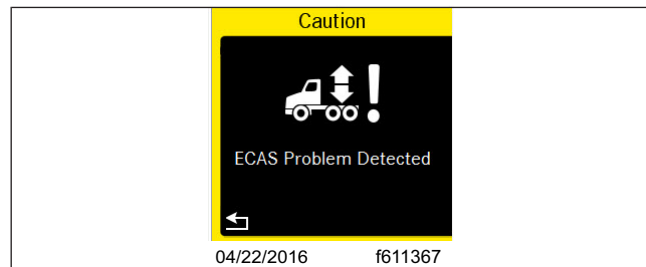

Fig. 3.28, ECAS Problem Detected Alert- ICUC

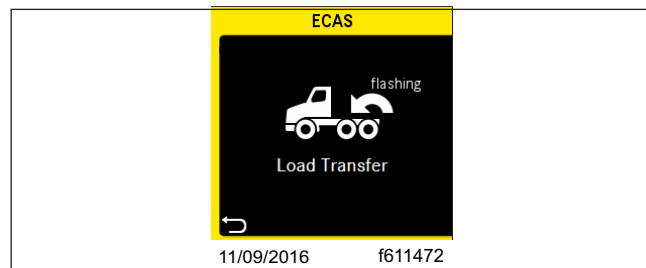

Fig. 3.29, Load Transfer Alert - ICUC

ICUC Vehicle Operations: Vehicle Settings

The ICUC Vehicle Operations menu has a submenu called Vehicle Settings. Settings and controls for vehicle features installed on the vehicle can be found here. These may include:

- Cruise Control
- Transmission
- Attention Assist
- Engine Idle Adjust
- Optimized Idle

Many of these may also be accessible under the Quick Access Systems menu.

Cruise Control

Settings for cruise control include setting the overspeed and underspeed in mph or kph and setting the following distance in seconds. For full instructions on standard cruise control, see [Chapter 7 Driver Assistance Features](#).

Transmission

The Transmission vehicle settings menu allows the driver to turn creep mode and eCoast on or off.

Creep mode is a DT12 Transmission feature that helps the driver move the vehicle at slow speeds by slipping the clutch to reduce torque to the wheels. It is designed to improve maneuverability in situations like parking, docking, and slow traffic.

To activate creep mode for the first time within the current driving cycle, press the accelerator pedal to launch the vehicle, thereby fully engaging the clutch. Stopping the vehicle with the service brake will not cause the vehicle to exit creep mode. While in creep mode, a lower gear may be selected and the transmission can be upshifted or downshifted with the shifter stalk.

The eCoast feature is standard on DT12 engines. On a downslope the clutch will momentarily disengage so the vehicle maintains momentum while the engine idles. Engine rpms will drop to 600 in eCoast mode. Input from the driver will cause the vehicle to exit eCoast mode.

For a fuller coverage of creep and eCoast mode see [Chapter 14](#) Automated and Automatic Transmissions.

Engine Idle Adjust

This feature allows the increase or decrease of the base engine idle speed. Increasing the base engine idle might be necessary to generate enough power to operate accessories.

The following conditions must be met to the engine idle speed to be adjusted:

- Engine is running
- Vehicle is at a standstill
- Transmission is in neutral

Optimized Idle

Optimized Idle reduces idle time by automatically stopping and restarting the engine. Besides saving fuel, it helps keep the batteries charged while maintaining engine and cab temperature.

The following conditions must be met for the optimized idle to function:

- Vehicle in neutral gear
- Park brake set

- Hood latched
- Sleeper fan on

Optimized Idle can be started with the engine running or the engine off.

With the key on, go to Vehicle Settings and scroll down to Optimized Idle. Press OK.

To enable optimized idle, press okay again. A screen will appear saying the default battery mode is on and interior comfort mode is off.

If you want to optimize the environment of the sleeper section, turn on comfort mode. Press the right hand arrow in the left hand switch pod to turn interior comfort mode on and then press OK.

The vehicle will go into standby mode, an under hood alarm will briefly sound, and the engine will crank and achieve 900 rpm. The ICUC screen will then state that it is in interior comfort mode and the engine and air conditioning/fan will run until it achieves the temperature requested by the driver. The engine will then shut down.

Optimized idle can be shut off by ICUC controls or pressing the brake. If the sleeper fan is turned off, optimized idle will not shut down but the engine will.

For a fuller description of Optimized Idle, see [Chapter 10](#) Optional Engine Systems.

Infotainment: ICUC

Safety Information



There is a risk of distraction from operating integrated communication equipment while the vehicle is in motion.

A driver can be distracted from the traffic situation if operating communication equipment integrated in the vehicle when driving, possibly causing loss of control of the vehicle.

Only operate this equipment when the road and traffic situation permits, otherwise stop and operate the equipment with the vehicle stationary.

The driver must observe the legal requirements of the country the vehicle is driving through when operating the system.

Wearing polarized sunglasses may impair or limit your ability to read the display.

Instruments

Navigation and Infotainment Reception

Features of both the navigation and infotainment system depend on cellular and satellite reception. In certain situations, such as driving through tunnels, mountains, or parked in multistory parking lots, reception may be impaired due to interference or there may be no reception at all.

General ICUC Infotainment Information

The ICUC infotainment system options consist of:

- AM/FM Radio
- Satellite Radio: SiriusXM®
- Weather Radio
- CD player
- USB & AUX input
- Smart phone Integration

ICUC Infotainment Screens

Use the Menu Up and Menu Down to navigate the infotainment screens:

1. Audio (AM/FM/Weather, SiriusXM, CD, USB, AUX). See [Fig. 3.30](#).
2. Telephone, showing signal strength, battery level, phone number, and active call length. See [Fig. 3.31](#).

ICUC Audio Features

Radio and Other Audio Sources

Radio stations, presets, and other audio sources can be accessed under Audio.

1. Select the single bar note icon to open the infotainment menu. The last infotainment menu accessed will open.
2. If not on the Audio screen, press the Up arrow in the left-hand steering wheel switch pod to move to this screen.
3. Press OK on the left-hand steering wheel switch pod to access Audio Settings.
4. Use the Right and Left arrows to navigate from one audio source to another—from radio to USB for example.



Fig. 3.30, Infotainment: Radio

5. Use the Up and Down arrows to navigate through an audio options list of choices. Choices can vary depending on the number of audio sources available and saved presets.
6. Press OK on the left-hand steering wheel switch pod to select an audio source. The audio source is selected.
7. Press the Back button to return to the main Audio screen.

Weather Radio (WX)

Weather Radio is an option under Audio.

Weather radio channels WX1 through WX7, corresponding to frequencies 162.400 MHz through 162.550 MHz, are the standard weather radio channels used by NOAA Weather Radio in the United States, Weatheradio Canada/Radiométéo Canada in Canada, and SARMEX in Mexico. Each system consists of a nationwide network of radio stations broadcasting official weather warnings, watches, advisories, forecasts and other non-weather related hazard information including news on natural disasters (earthquakes, avalanches, floods), environmental hazards (oil spills, chemical releases), and public safety messages (AMBER alerts, network

outages). All services operate 24 hours a day, 7 days a week.

The average range for reception from a transmitter is approximately 40 miles (60 km). The National Weather Service operates more than 1000 transmitters.

Adjusting the Volume

Volume can be adjusted up using the VOL+ and down using the —VOL switches in the left-hand steering wheel switch pod.

ICUC Telephone Features

Telephone is the second screen under infotainment. The main telephone screen shows the connected phone's current signal and battery strength. If a call is in progress it will show the phone number and call length.

Telephone Settings



Fig. 3.31, Infotainment: Active Call

Telephone settings displays the phone's call history, contacts, and any contact presets.

1. Select the single bar note icon to open the infotainment menu. The last infotainment menu accessed will open.

2. If not on the Telephone Screen, use the down arrow in the left-hand steering wheel switch pod to move to this screen.
3. When on the Telephone screen, select OK on the left-hand steering wheel switch pod to access Telephone Settings.
4. Use the right and left arrows to navigate from one telephone setting to another—from contacts to missed calls for example.
5. Use the up and down arrows in the left-hand steering wheel switch pod to navigate through the current Telephone Settings list of choices.
6. Press OK on the left-hand steering wheel switch pod to choose an option.
7. Press the back left-hand steering wheel switch pod to return to the main screen.

Analog Instruments

Physical instruments are listed here in alphabetical order. Some are optional and therefore not found in every vehicle. Digital instruments and gauges are described in their ICU section.

Air Intake Restriction Gauge

The air intake restriction gauge indicates the vacuum on the engine side of the air cleaner. On standard installations, it is mounted on the air intake duct in the engine compartment, and has a go/no-go restriction indicator without graduations. See [Fig. 3.32](#). As an option, a graduated indicator, shown in [Fig. 3.33](#), on the air intake duct or, for easier viewing, a dash-mounted restriction gauge may be installed.

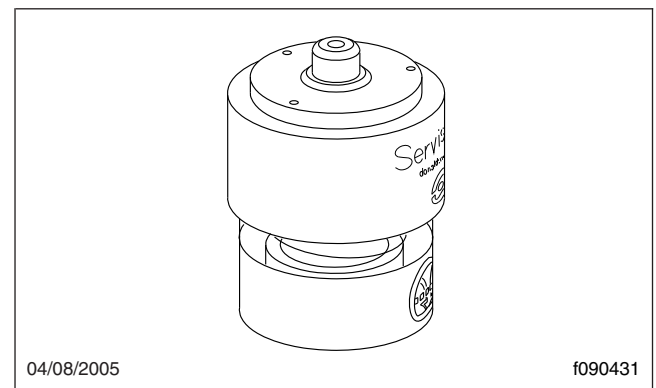

Fig. 3.32, Manual-Reset Air Restriction Indicator, Go/No-Go

Instruments

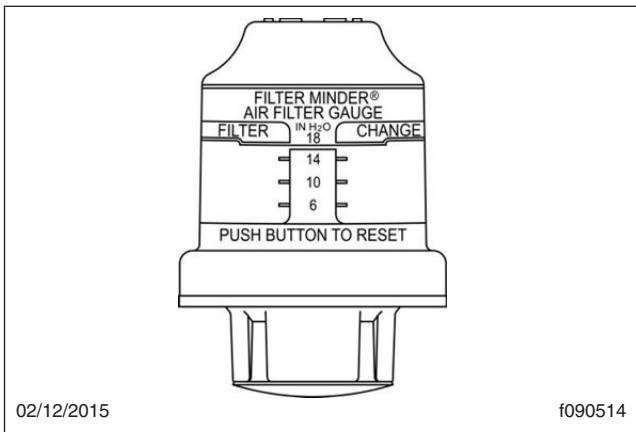

Fig. 3.33, Air Intake Restriction Indicator, Graduated

Air intake restriction vacuum is measured in inches of water (inH₂O). For vehicles equipped with a graduated indicator or a restriction gauge on the dash, check the gauge with the engine off. If the yellow signal stays locked in the red zone once the engine is shut down, or is at or above the values shown in [Table 3.1](#), the air cleaner element needs to be replaced.

Air Intake Maximum Restriction Values (inH ₂ O)	
Engine Make	GHG14, GHG17, and GHG21 Engines
Cummins	25
Detroit	18

Table 3.1, Air Intake Maximum Restriction Values

NOTE: Rain or snow can wet the filter and cause a temporary high reading.

Application Air Pressure Gauge

An application air pressure gauge registers the air pressure being used to apply the brakes, and should be used for reference only. See [Fig. 3.34](#). The gauge will not register air pressure until the foot brake pedal is depressed or the trailer hand brake is applied.

Coolant Temperature Gauge

NOTICE

A sudden increase in coolant temperature may indicate engine or cooling system failure. Bring the vehicle to a safe stop and investigate the cause to prevent further damage. Do not operate

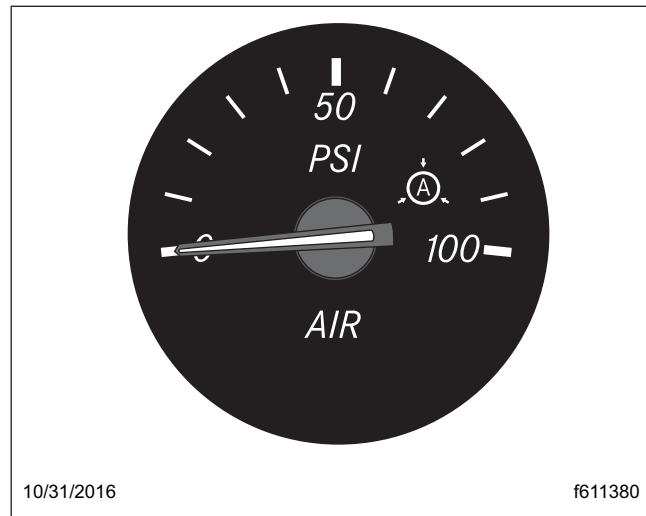

Fig. 3.34, Application Air Pressure Gauge

the engine until the cause has been determined and corrected.

During normal engine operation, the coolant temperature gauge should read 175 to 195°F (79 to 91°C). If the temperature remains below 160°F (71°C), inspect the cooling system to determine the cause. See [Fig. 3.35](#).



Fig. 3.35, Analog Coolant Temperature Gauge - ICUC

For Detroit engines, if coolant temperature rises above the maximum temperature listed in [Table 3.2](#), the CHECK engine lamp will illuminate. If the condition does not improve, the STOP engine lamp will also illuminate and an audible warning will sound. The engine will then derate or shut down, depending on the type of engine protection system installed.

Maximum Coolant Temperature	
Engine Make	Temperature: °F (°C)
Cummins	225 (107)
Detroit	215 (101)

Table 3.2, Maximum Coolant Temperature

Drive Axle Oil Temperature Gauges

NOTICE

A sudden increase in oil temperature that is not caused by a load increase may indicate mechanical failure. Bring the vehicle to a safe stop and investigate the cause to prevent further damage. Do not operate the vehicle until the cause has been determined and corrected.

During normal operation, the drive axle oil temperature gauges should read as follows:

- 160 to 220°F (71 to 104°C) for Detroit Classic Model 2, 4, and 6 axles.
- 160 to 329°F (71 to 165°C) for Detroit New Final Drive (NFD) axles.
- 160 to 275°F (71 to 135°C) for Meritor™ drive axles.
- 180 to 200°F (82 to 93°C) for Dana Spicer® drive axles.

Under heavy loads, such as when climbing steep grades, temperatures that exceed the normal oil temperature range for a short period are not unusual. If the temperature returns to normal when the load decreases, there is no problem. See [Fig. 3.36](#).

Engine Oil Pressure Gauge

NOTICE

A sudden decrease or absence of oil pressure may indicate mechanical failure. Bring the vehicle to a safe stop and investigate the cause to prevent further damage. Do not operate the engine until the cause has been determined and corrected.

The engine oil pressure gauge displays the current engine oil pressure. If engine oil pressure falls below the minimum levels shown in [Table 3.3](#), the CHECK engine lamp will illuminate. If the condition does not improve, the STOP engine lamp will also illuminate and an audible warning will sound. The engine will

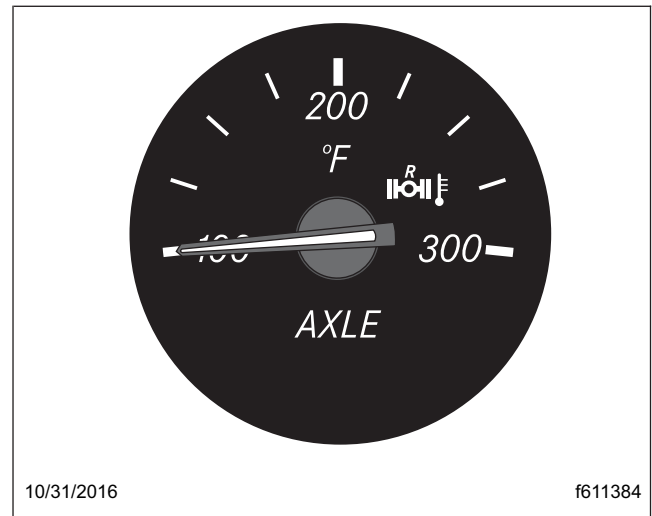

Fig. 3.36, Drive Axle Oil Temperature Gauge (rear drive axle gauge shown)



Fig. 3.37, Analog Engine Oil Pressure Gauge - ICUC

then derate or shut down, depending on the type of engine protection system installed.

NOTE: Oil pressures in [Table 3.3](#) are given with the engine at operating temperature. With the engine cold, oil pressure may be higher. Individual engines may vary from the listed pressures; observe and record pressures when the engine is new to create a guide for checking engine condition.

Instruments

Minimum Oil Pressure*		
Engine Model	At Idle Speed: psi (kPa)	At Rated RPM: psi (kPa)
Cummins	15 (103)	35 (241)
Detroit	14 (97)	55 (350)

* Oil pressures are given with the engine at operating temperature. With the engine cold, oil pressure may be higher. Individual engines may vary from the listed pressures; observe and record pressures when the engine is new to create a guide for checking engine condition.

Table 3.3, Minimum Engine Oil Pressure

Engine Oil Temperature Gauge

NOTICE

A sudden increase in oil temperature that is not caused by a load increase may indicate mechanical failure. Bring the vehicle to a safe stop and investigate the cause to prevent further damage. Do not operate the engine until the cause has been determined and corrected.

During normal operation, the optional engine oil temperature gauge should read in the following temperature range:

- 200 to 260°F (93 to 126°C) for Detroit and Cummins engines

Under heavy loads, such as when climbing steep grades, temperatures that exceed the normal oil temperature range for a short period are not unusual. If the temperature returns to normal when the load decreases, there is no problem. See [Fig. 3.37](#) and [Fig. 3.38](#).

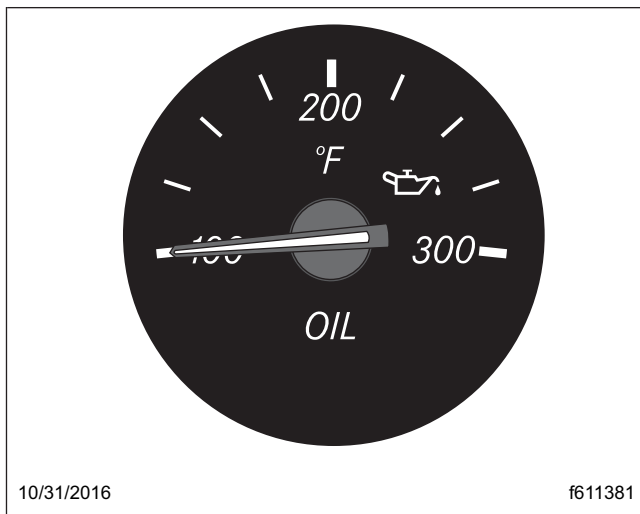

Fig. 3.38, Engine Oil Temperature Gauge

Fuel/Diesel Exhaust Fluid (DEF) Gauge

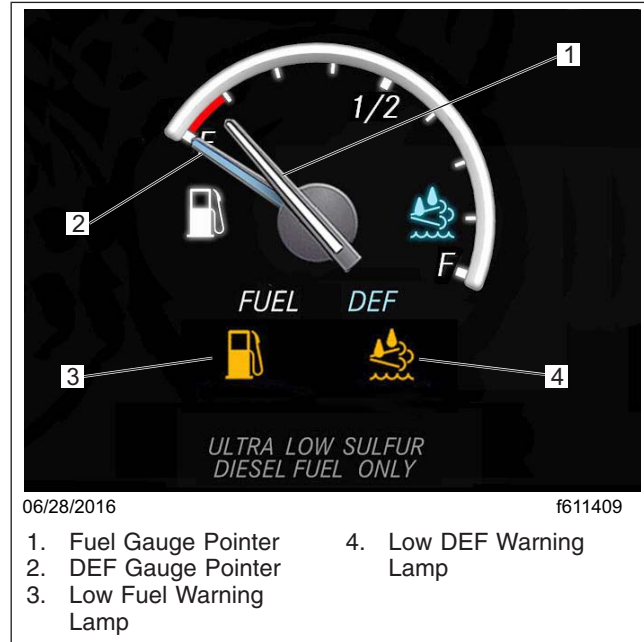

Fig. 3.39, Fuel/DEF Gauge

The fuel and DEF levels can be measured in a dual purpose fuel/DEF level gauge. See [Fig. 3.39](#).

The diesel fuel and DEF levels are indicated on the gauge. A low fuel warning lamp illuminates amber when the diesel fuel level registers 1/8th of capacity. The low DEF warning lamp illuminates amber when the DEF level reaches 10% of capacity. See [Chapter 13 Emissions](#), for details of the DEF gauge functions.

Primary and Secondary Air Pressure Gauges

WARNING

If air pressure falls below minimum pressure, the braking ability of the vehicle will be limited. Slow the vehicle down and bring it to a gradual stop. Do not attempt to move the vehicle until air pressure has risen above the minimum level. Moving a vehicle without adequate braking power could cause an accident resulting in property damage, personal injury, or death.

Air pressure gauges register the pressure in the primary and secondary air systems. See [Fig. 3.40](#).

Normal pressure, with the engine running, is 100 to 120 psi (689 to 827 kPa) in both systems.

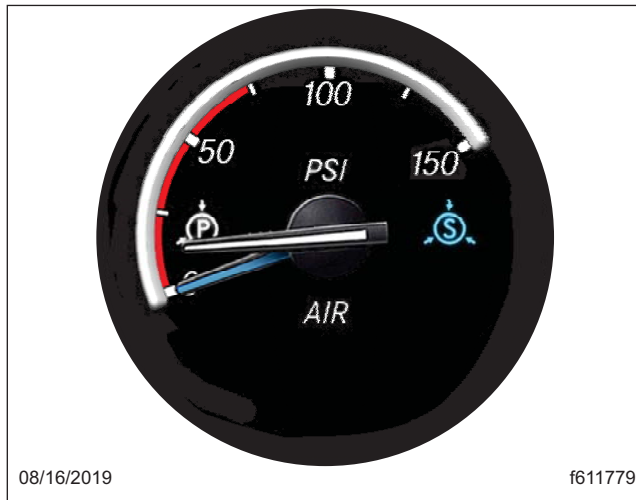

Fig. 3.40, Analog Combined Application Air Pressure Gauge - ICUC

NOTE: The low-air warning buzzer only works when the park brake is released. The low-air warning buzzer is silenced when the park brake is set.

If air pressure drops below approximately 70 psi (483 kPa), a warning light illuminates and the driver display shows a warning. A low-air warning buzzer also sounds if the park brake is not set.

NOTE: If the pressure in both air systems drops below 70 psi, the parking brakes will drag or apply.

Speedometer

The U.S. version of the speedometer shown in [Fig. 3.41](#) registers speed in both miles per hour (mph) and kilometers per hour (km/h), with mph in larger numbers. The metric version of the speedometer face reverses this arrangement, with km/h in larger numbers.

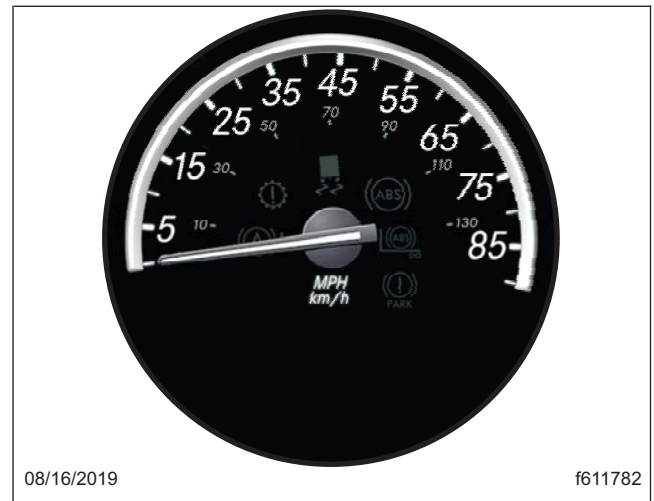

Fig. 3.41, Analog Speedometer - ICUC

Suspension Air Pressure Gauge

A suspension air pressure gauge registers the air pressure applied to the vehicle air suspension. See [Fig. 3.42](#).

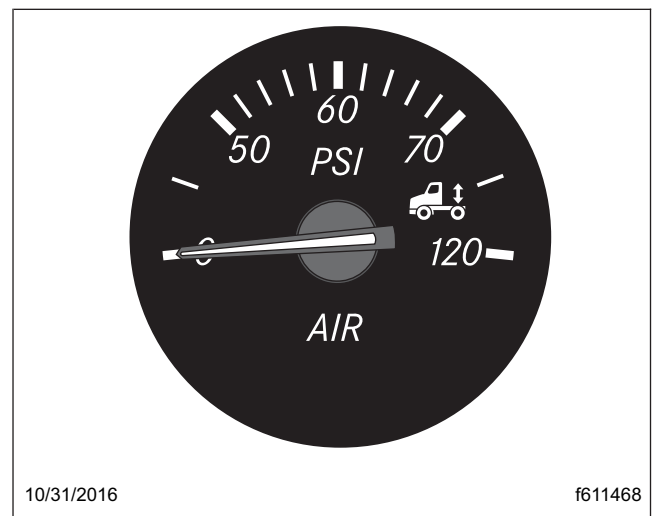

Fig. 3.42, Suspension Air Pressure Gauge

Tachometer

The tachometer or rev counter indicates engine speed in revolutions per minute (rpm) and serves as a guide for shifting the transmission and keeping the engine in the appropriate rpm range. The tachometer has only one unit of measurement, 0-2500 rpm. For low idle and rated rpm, consult your vehicle's engine identification plate. See [Fig. 3.43](#).

Instruments

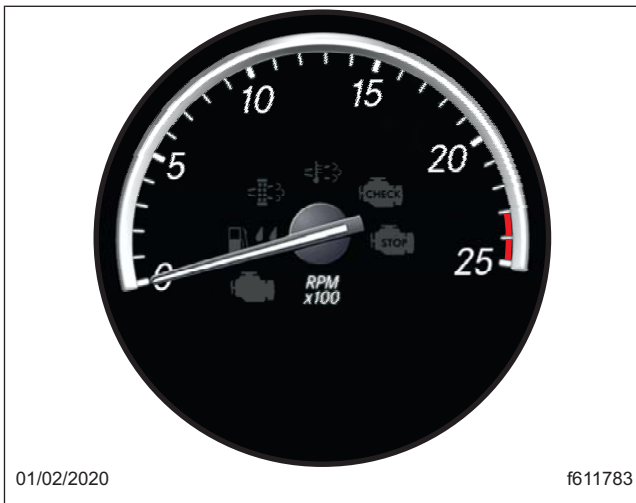

Fig. 3.43, Analog Tachometer - ICUC

Transmission Fluid Temperature Gauge

The transmission fluid temperature gauge, measures the transmission lubricant operating temperature. See Fig. 3.44. Temperatures vary by application, but the transmission fluid temperature gauge reading should not exceed 250°F (121°C).

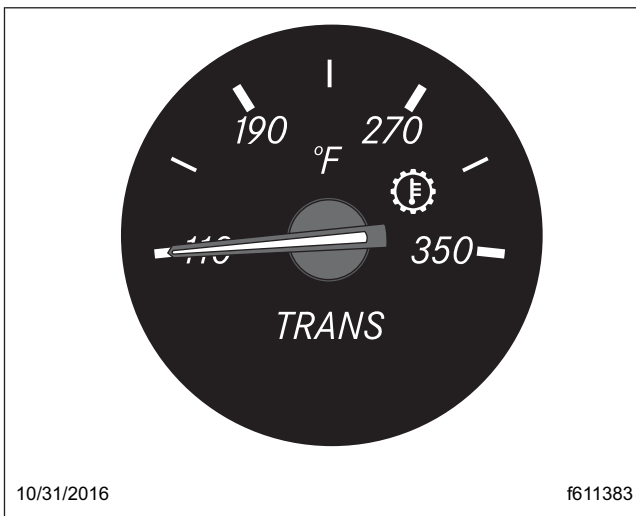

Fig. 3.44, Transmission Fluid Temperature Gauge

NOTICE

A sudden increase in transmission fluid temperature that is not caused by a load increase may indicate mechanical failure. Bring the vehicle to a safe stop and investigate the cause to

prevent further damage. Do not operate the vehicle until the cause has been determined and corrected.

Under heavy loads, such as when climbing steep grades, temperatures that exceed the normal oil temperature range for a short period are not unusual. If the temperature returns to normal when the load decreases, there is no problem.

Turbocharger Boost Pressure Gauge

A turbocharger boost pressure gauge indicates the pressure in the intake manifold, in excess of atmospheric pressure, being created by the turbocharger. See Fig. 3.45.

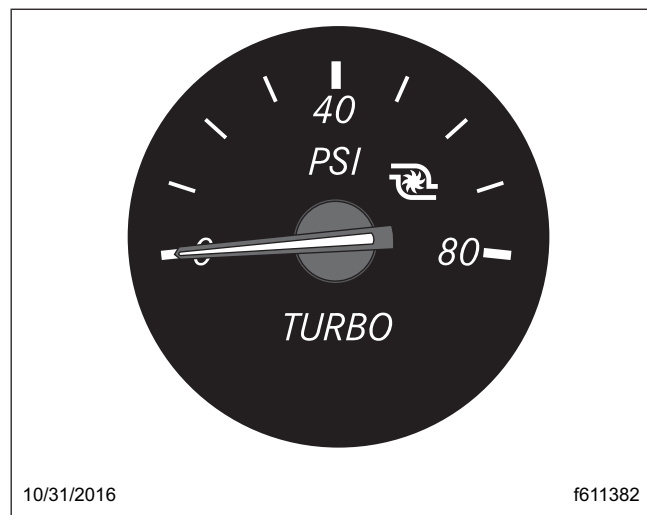

Fig. 3.45, Turbocharger Boost Pressure Gauge

Voltmeter

The voltmeter indicates the vehicle charging system voltage when the engine is running and the battery voltage when the engine is off. By monitoring the voltmeter, the driver can stay aware of potential battery charging problems and have them fixed before the batteries discharge enough to create starting difficulties.

The voltmeter will normally show approximately 13.7 to 14.1 volts when the engine is running. The voltage of a fully charged battery is 12.7 to 12.8 volts when the engine is off. Battery voltage under 12.0 volts is considered a low battery, and a completely discharged battery will produce only about 11.0 volts.

If the voltmeter shows an undercharged or overcharged condition for an extended period, have

the charging system and batteries checked at an authorized Freightliner service facility.

On a vehicle equipped with a battery isolator system, the voltmeter measures the average voltage of all the batteries when the engine is running. When the engine is off, the voltmeter shows only the isolated battery voltage and does not indicate the voltage of the engine-starting batteries.

Overhead Instrument Panel

The overhead instrument panel, shown in [Fig. 3.46](#), may hold a citizen's band (C/B) radio, a microphone clip, and any switches that can not be accommodated on the driver's or auxiliary dash panels.



Fig. 3.46, Overhead Instrument Panel

The underside of the overhead console also holds the sun visors and the optional dome/reading light assembly. For more information on the dome/reading light assembly, see [Chapter 4](#).

Warnings, Indicators, and Messages

Audible Alerts: ICUC

An audible alert sounds whenever one of the following conditions exists:

- Engine oil pressure falls below the minimum preset value.
- Coolant temperature rises above the maximum preset value.
- Air pressure falls below approximately 70 psi (483 kPa).
- Parking brake is set with the vehicle moving faster than 2 mph (3 km/h).
- System voltage falls below 11.9 volts.
- Door is unlatched with the parking brake off.

Optional audible alert sounds whenever one of the following conditions exists:

- Driver seat occupancy sensor reads someone in the seat with the seat belt not fastened and the parking brake off.
- Key is in the ignition and the door is unlatched.









Warnings, Indicators, and Messages











Warning and indicator lights (telltales) with icon symbols are displayed on the physical dashboard and on ICU screens. The positions of the telltales and warnings vary, but most telltale symbols are standard. See the below tables for a listing of different warnings and telltales in addition to messages and popup screens.

The colors of telltales and warnings indicate the hazard level: red (warning), amber (caution), green and blue (active status), grey (passive status), white (informational). Blue is currently used to indicate an active phone call, that a software download is available, and that utility lamps and high beams are on.

IMPORTANT: Depending upon local jurisdictional emissions guidelines, vehicles and/or engines that are domiciled outside of the U.S. and Canada may not be compliant with EPA10 or GHG21 regulations. Noncompliant vehicles may not be equipped with all of the telltales shown in the below tables.

Instruments

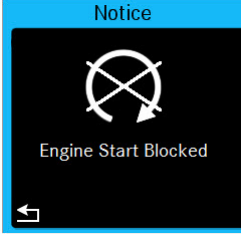
Warnings, Indicators, and Messages				
Engine System				
Telltale	Color	Description		Related Messages
	Red	Stop Engine*	<p>Indicates a serious fault that requires engine shutdown immediately. The engine protection system will reduce the maximum engine torque and speed, and, if the condition does not improve, will shut down the engine within 30 to 60 seconds.</p> <p>Safely bring the vehicle to a stop on the side of the road and shut down the engine as soon as the red light is seen. If the engine shuts down while the vehicle is in a hazardous location, turn the key to the OFF position for a few seconds, then restart the engine and move the vehicle to a safer location.</p>	Various
	Red	Engine Oil Level Warning		
	Red	Low Engine Oil Pressure	Indicates the engine oil pressure is below the minimum allowable pressure.	 <p>04/22/2016 f611368 ICUC Warning</p>
	Red	Engine Oil Temperature Warning		
	Red	Low Coolant Level		
	Red	High Coolant Temperature	Indicates the coolant temperature is above the maximum allowable temperature.	 <p>04/22/2016 f611371 ICUC Warning</p>

Warnings, Indicators, and Messages				
Engine System				
Telltale	Color	Description		Related Messages
	Amber	Check Engine*	Indicates an engine condition (low oil pressure, low coolant level, high coolant temperature, high DPF soot level, uncontrolled DPF regeneration, or battery voltage 11.9 volts or less) that requires correction. Correct the condition as soon as possible. If the condition worsens, the STOP engine lamp will illuminate.	Various
	Amber	Engine Malfunction Indicator Lamp (MIL)*	A steadily illuminated amber MIL lamp indicates an engine fault that effects emissions.	
	Amber	Engine Malfunction Indicator Lamp (MIL)*	Alternate Engine Malfunction Indicator lamp. A steadily illuminated amber MIL lamp indicates an engine fault that effects emissions.	
	Amber	Engine Oil Level Caution		
	Amber	Engine Oil Pressure Caution		
	Amber	Low Coolant Level Caution		
	Amber	High Coolant Temperature Caution		
	Amber	Start Blocked	Indicates that the system is preventing the starter from cranking. This can occur when the ignition switch is turned to START before the gauge sweep has completed. NOTE: Display of the Start Blocked screen does not indicate a problem with the starter. Turn the ignition switch back to ON, wait for the message to turn off, then turn the ignition switch to START again.	 04/22/2016 f611369 ICUC Notice
	Amber	Start Blocked	Alternative Telltale for Start Blocked.	
	Green	Start Engine		

Instruments

Warnings, Indicators, and Messages				
Engine System				
Telltale	Color	Description		Related Messages
	Green	Optimized Idle Active	Indicates optimized idle is active.	

Table 3.4, Engine Related Indicators

*See **Chapter 13** Emissions for an explanation of the after treatment system (ATS) warning indicators, and actions required to avoid further engine protection steps.







Telltales, Indicator Icons, and Messages				
Transmission				
Telltale	Color	Description		Related Messages
	Red	Transmission Fluid Level Warning	Indicates low transmission fluid level. Safely bring the vehicle to a stop as soon as possible.	
	Amber	Caution Check Transmission	Indicates an undesirable transmission condition.	
	Amber	Low Transmission Fluid Level Caution	Indicates low transmission fluid level.	
	Amber	High Transmission Temperature	Indicates transmission is overheating.	

Table 3.5, Transmission Related Indicators

Telltales, Indicator Icons, and Messages				
Brakes				
Telltale	Color	Description		Related Messages
	Red	Low Brake Air Pressure (EPA10 and Newer)	Indicates air pressure in the primary or secondary reservoir has dropped below approximately 70 psi (483 kPa).	



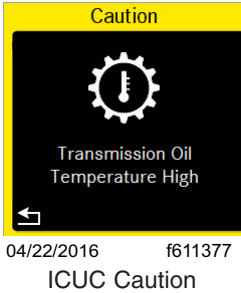













Telltale, Indicator Icons, and Messages				
Brakes				
Telltale	Color	Description		Related Messages
	Red	Low Brake Air Pressure (EPA10 and Newer)	Alternate low brake air pressure telltale. Indicates air pressure in the primary or secondary reservoir has dropped below approximately 70 psi (483 kPa).	 06/30/2016 f611429 ICUC Warning
	Red	Parking Brake Engaged (EPA10 and Newer)	Indicates the parking brake is engaged.	
	Red	Parking Brake Engaged (EPA10 and Newer)	Alternative icon indicating the parking brake is engaged.	
	Amber	Hill Holder Assist Off		
	Amber	Hill Start Aid Engaged		
	Amber	Winch Brake Caution		
	Amber	Work Brake Caution		
	Green	Descent Control Mode Engaged		
	Green	Engine Brake Engaged	Indicates the engine brake is enabled.	

Table 3.6, Brake Related Indicators

Instruments

Telltale, Indicator Icons, and Messages				
Driving Safety				
Telltale	Color	Description	Related Messages	
	Amber	Electronic Stability Control (ESC) Active	Flashing indicates a stability event has been detected, and the ESC system is active. Solid illumination indicates a problem with the stability system. Repair the ESC system immediately to ensure full stability capability.	
	Amber	Electronic Stability Program Off		
	Amber	Tractor Anti-Lock Braking System (ABS)	Momentary illumination indicates the vehicle ABS is engaged. Solid illumination indicates a problem with the vehicle ABS. Repair the ABS immediately to ensure full braking capability.	
	Amber	Trailer Anti-Lock Braking System (ABS)	Momentary illumination indicates the trailer ABS is engaged. Solid illumination indicates a problem with the trailer ABS. Repair the ABS immediately to ensure full braking capability.	
	Amber	Active Brake Assist Active	Indicates Active Brake Assist is engaged.	
	Amber	Active Brake Assist Unavailable (GHG14 and newer)	Indicates the Active Brake Assist system is not available.	 <p>04/22/2016 f611353 ICUC Caution</p>
 ICUC Telltale	Amber	Lane Departure Unavailable	Indicates that lane departure warning is disabled due to minimum speed, lack of lane markings, or system not being available. NOTE: Only on vehicles equipped with Detroit Assurance radar.	 <p>06/28/2016 f611372 ICUC Caution</p>

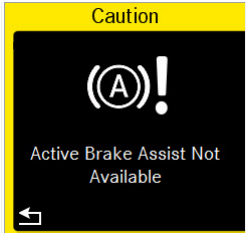















Telltale, Indicator Icons, and Messages				
Driving Safety				
Telltale	Color	Description		Related Messages
 ICUC Telltale	Amber	Adaptive Cruise Control Not Available	Indicates that Adaptive Cruise Control (ACC) is not available NOTE: Only on vehicles equipped with a radar-based collision warning and mitigation system (CWS/CMS).	 04/22/2016 f611354 ICUC Caution If ACC is not available, Active Lane Assist (ALA) will not be available.
	Amber	IPPC Error		
	Green	Adaptive Cruise Control Active		
	Red	Adaptive Power Steering (APS) Error		An error with APS deactivates Active Lane Assist (ALA).
	Blue	Lane Keep Assist (LKA) Active	LKA is a component of Active Lane Assist (ALA) along with Lane Departure Protection (LDP). If Adaptive Cruise Control (ACC) is not available, ALA will not be available.	This is also the Switch icon
	Grey	Lane Keep Assist (LKA) on Standby		When LKA is OFF there is no steering wheel icon
	Amber	Gear Teach Mode in Progress		
	Green	AERO active	Indicates that aerodynamic height control (AERO) is active.	

Table 3.7, Driving Safety Related Icons

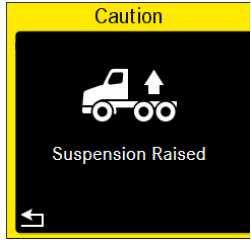
Instruments

Telltale, Indicator Icons, and Messages				
Suspension				
Telltale	Color	Description		Related Message
	Amber	Suspension Higher than Normal Ride Height / Axle Lifted	Indicates the current rear suspension height is above the normal ride height.	 <p>11/09/2016 f611471 ICUC Caution</p>
	Amber	Suspension Lower Than Normal Ride Height / Axle Dropped	Indicates the current rear suspension height is below the normal ride height.	 <p>06/29/2016 f611434 ICUC Caution</p>
	Amber	Suspension Height		
	Amber	Electronically Controlled Air Suspension (ECAS) Error	Indicates Electronically Controlled Air Suspension (ECAS) active fault.	 <p>04/22/2016 f611367 ICUC Caution</p>
	Amber	Load Transfer	Indicates the ECAS system is applying the maximum available vehicle load on the drive axle up to the maximum gross axle weight rating (GAWR).	 <p>11/09/2016 f611472 ICUC Caution</p>

Telltale, Indicator Icons, and Messages				
Suspension				
Telltale	Color	Description		Related Message
	Amber	5th Wheel Adjust		

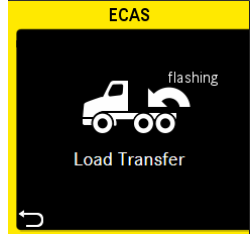
Table 3.8, Suspension Related Indicators







Telltale, Indicator Icons, and Messages				
Battery				
Telltale	Color	Description		Related Messages
	Red	Battery Critical		
	Red	Battery Failure		
	Amber	Battery Failure		

Table 3.9, Battery Related Indicators

Telltale, Indicator Icons, and Messages				
Tire Related Indicators				
Telltale	Color	Description		Related Messages
	Red	Low Tire Pressure Warning	Indicates a notable loss of tire pressure in at least one tire.	If a tire monitoring system is available, the tire(s) with low pressure will be highlighted red.
	Amber	Low Tire Pressure Warning	Indicates low tire pressure in at least one tire.	If a tire monitoring system is available, the tire(s) with low pressure will be highlighted amber.
	Amber	Automatic Traction Control (ATC) Active	Flashing indicates a wheel spin event has been detected, and the ATC system is active.	

Instruments

Telltale, Indicator Icons, and Messages				
Tire Related Indicators				
Telltale	Color	Description		Related Messages
	Amber	Automatic Traction Control (ATC) Deactivated	Indicates the ATC SPIN button has been pressed to allow wheel slip.	 10/24/2017 f611457c ICUC Caution

Table 3.10, Tire Related Indicators



Telltale, Indicator Icons, and Messages				
Fuel				
Telltale	Color	Description		Related Messages
	Amber	Low Fuel	Indicates low fuel level. Refill the main fuel tank.	
	Amber	Water in Fuel Warning	Indicates the fuel may contain water. Drain any water collected in the fuel/water separators.	

Table 3.11, Fuel Related Indicators

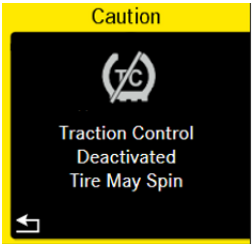
Telltale, Indicator Icons, and Messages				
Diesel Exhaust Fluid (DEF) and Diesel Particulate Filter (DPF)				
Telltale	Color	Description		Related Messages
	Red	Diesel Particulate Filter Critical	Indicates a parked regen is required immediately.	 06/10/2016 f611403 ICUC Warning





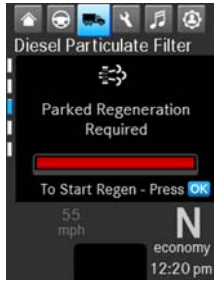

Telltale, Indicator Icons, and Messages			
Diesel Exhaust Fluid (DEF) and Diesel Particulate Filter (DPF)			
Telltale	Color	Description	Related Messages
	Amber	Diesel Particulate Filter (DPF) Status	<p>Solid illumination indicates a regen is required. Change to a more challenging duty cycle (such as highway driving) to raise exhaust temperatures for at least twenty minutes, or perform a parked regen.</p> <p>Blinking indicates that a parked regen is required immediately. An engine derate and shutdown will occur.</p>  <p>06/10/2016 f611401</p> <p>ICUC Caution</p>
	Amber	Diesel Particulate Filter Inhibited	
	Green	Diesel Particulate Filter Regeneration in Progress	Indicates a regen is in progress.
	Amber	High Exhaust System Temperature (HEST)*	<p>Slow (10-second) flashing indicates a regeneration (regen) is in progress.</p> <p>IMPORTANT: When the HEST lamp is illuminated, do not park the vehicle near objects that can be harmed by high temperatures or flammable materials.</p> <p>Solid illumination indicates high exhaust temperatures at the outlet of the tail pipe when speed is below 5 mph (8 km/h).</p>
	Amber	Low Diesel Exhaust Fluid	<p>Indicates low diesel exhaust fluid.</p> <p>Fill the DEF tank.</p>
	Amber	Low Diesel Exhaust Fluid	<p>Alternative icon to indicate Low Diesel Exhaust Fluid.</p> <p>Fill the DEF tank.</p>

Table 3.12, Diesel Exhaust Fluid (DEF) and Diesel Particulate Filter (DPF) Related Icons

Instruments













Telltale, Indicator Icons, and Messages				
Lamps				
Telltale	Color	Description		Related Information
	Green	Right-Turn Indicator On	Flashing indicates the outside right-turn signal lamps are activated.	
	Green	Left-Turn Indicator On	Flashing indicates the outside left-turn signal lamps are activated.	
	Blue	High-Beams On	Indicates the high-beam headlights are on.	
	Green	Low-Beams On	Indicates the low-beam headlights are on.	
	Blue	Automatic High-Beams On	Indicates the high-beam headlights have been set to automatic and are on.	
	Grey	Automatic High-Beams Off	Indicates the high-beam headlights have been set to automatic and are off.	
	Green	Automatic Low-Beams On	Indicates the low-beam headlights have been set to automatic and are on.	
	Grey	Automatic Low-Beams Off	Indicates the low-beam headlights have been set to automatic and are off.	
	Green	Daytime Running Lamps On	Indicates the daytime running lamps are on.	
	Blue	Auxiliary Drive Lamps On	Indicates the auxiliary drive lamps are on.	
	Blue	Utility Lamps On	Indicates the utility lamps are on.	
	Green	Taillights / Marker Lamps On	Indicates the taillights, aka marker lamps, are on.	

Table 3.13, Lamp Indicators





Telltale, Indicator Icons, and Messages				
Passenger Safety				
Telltale	Color	Description		Related Message
	Red	Unfastened Seat Belt	<p>On some vehicles, activates with an audible alert when the system detects that the parking brake is off and the driver seat belt is not fastened.</p> <p>On vehicles with a seat occupancy sensor, the seat being occupied, seat belt not fastened, and parking brake off will cause this warning to activate.</p> <p>On other vehicles, this lamp illuminates for 15 seconds when the ignition is first turned on.</p>	
	Amber	Supplemental Restraint System (SRS) Error	<p>Indicates a malfunction has occurred in the restraint system and restraint system components may be triggered unintentionally or may not deploy as intended during an accident.</p> <p>Have the restraint system checked and repaired immediately.</p>	
	White	Left-Hand Door Unlatched	M2 crew cab left-hand door unlatched	
	White	Right-Hand Door Unlatched	M2 crew cab right-hand door unlatched	
	White	Both Doors Unlatched	M2 crew cab both doors unlatched	

Table 3.14, Passenger Safety Indicators

Instruments



Telltales, Indicator Icons, and Messages				
Weather				
Telltale	Color	Description		Related Pop-Up Message
	White	Snowflake	Indicates ambient air temperature has dropped below 34°F (1°C). Pay attention to road conditions and watch for ice.	 <p>05/29/2019 f611753a ICUC Caution</p>

Table 3.15, Weather Related Indicator





Telltales, Indicator Icons, and Messages				
ICU Application Icons				
Telltale	Color	Description		Related Information
	Blue	Active Phone Call	Indicates a phone is connected to the ICU and a call is active.	The phone screen in the infotainment section of the ICU will also show an active call, including the number being called and call length.
	Blue	Software Download Available	Indicates a software download is available. For reasons of security and optimal vehicle functioning, software updates should be quickly installed.	A pop-up message will also appear.

Table 3.16, ICU Application Icons

Telltales, Indicator Icons, and Messages				
Air Gauge Indicators				
Telltale	Color	Description		Related Messages
	Red	Primary Air Warning		
	Red	Secondary Air Warning		
	Red	Application Air Warning		

Telltale, Indicator Icons, and Messages			
Air Gauge Indicators			
Telltale	Color	Description	Related Messages
	Amber	Primary Air Caution	

Table 3.17, Air Gauge Indicators

Engine Protection System



When the red STOP engine lamp illuminates, most engines are programmed to shut down automatically within 30 seconds. The driver must immediately move the vehicle to a safe location at the side of the road to prevent causing a hazardous situation that could cause bodily injury, property damage, or severe damage to the engine.

See [Chapter 13 Emissions](#) for an explanation of the aftertreatment system (ATS) warning indicators, and actions required to avoid further engine protection steps.

The STOP engine lamp illuminates when the engine protection system is activated in one of two ways. On some engines, the engine protection system will derate the engine, allowing it to run at lower rpm and slower vehicle speed. Drive the vehicle to a safe location or to a service facility.

IMPORTANT: Safely bring the vehicle to a stop on the side of the road and shut down the engine as soon as the red light is seen. If the engine shuts down while the vehicle is in a hazardous location, turn the key to the OFF position for a few seconds, then restart the engine and move the vehicle to a safer location.

On other engines, the engine protection system will shut down the engine. It will first derate the engine, then shut it down completely 30 to 60 seconds after the indicator illuminates (depending on the critical fault type) if the condition does not improve. Bring the vehicle to a stop on the side of the road before the engine shuts down.

Some vehicles may have a shutdown-override switch, which may be used to momentarily override the shutdown sequence. See [Chapter 9 Engine](#)

Starting, Operation, and Shutdown for detailed information regarding the shutdown process.

IMPORTANT: Do not attempt to restart the engine while the vehicle is moving. Bring the vehicle to a safe stop, then restart the engine.

To restart the engine, turn the ignition to OFF, leave it there a few seconds, then turn the ignition to START. The engine will run for a short period and shut down again if the condition does not improve.

4

Driver Controls

Ignition Switch and Key	4.1
Adjustable Steering Column	4.1
Windshield Wiper and Washer Controls	4.1
Exterior Lighting Controls	4.3
Horn Controls	4.6
Dash-Mounted Brake Controls	4.6
Powertrain Controls	4.7
AWD Controls	4.9
Other Dash-Mounted Controls	4.11

Driver Controls

Ignition Switch and Key

The ignition switch, shown in [Fig. 4.1](#), has four positions: ACCESSORY, OFF, ON, and START.

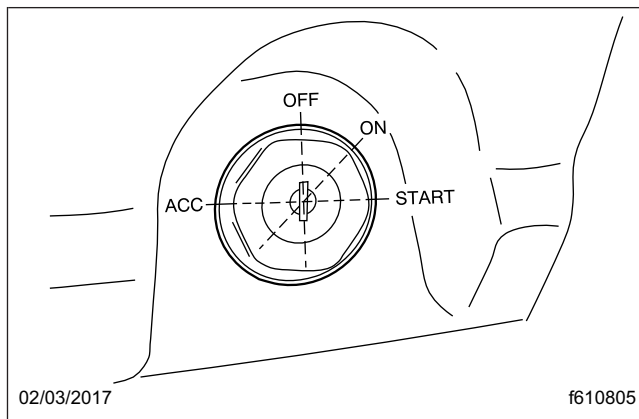

Fig. 4.1, Ignition Switch Positions

In the OFF position, the key slot is vertical; the key can be inserted and removed only in the OFF position. If equipped, the following can be operated in the off position (regardless of whether the key is inserted):

- low-beam headlights
- taillights
- brake lights
- road lights
- dome lights
- clearance lights
- hazard warning lights
- turn signals
- power windows
- cigarette lighter
- horn
- clock
- CB radio
- electric oil pan heater

In the ACCESSORY position, the key is turned counterclockwise. The following functions will operate when the switch is in the ACC position:

- ICU
- radio/stereo system

- mirror heat
- air dryer
- backup lights

In the ON position, the key is turned clockwise and all electrical systems are operable. The warning and indicator lamps will illuminate.

IMPORTANT: Do not crank the engine until the ICU self-check is complete.

The low air pressure and low oil pressure warning telltales (or messages) may appear until the engine starts and the pressure builds up.

Turn the key clockwise past the ON position to reach the START position to start the engine. Release the key the moment the engine starts. Do not operate the starter longer than thirty seconds. Allow the starter to cool between attempts. If the starter overheats, the starter protection system will prevent operation of the starter until it has cooled.

Adjustable Steering Column

To unlock the steering column to adjust it, pull the steering column locking lever out and away from the column. See [Fig. 4.2](#). With the column unlocked, the steering wheel can be adjusted up-and-down and tilted fore-and-aft. Once the wheel is in the desired position, lock the position by pushing the lever in toward the column until it goes no further and is parallel to the column itself.

WARNING

Make sure that the steering column is locked before driving the vehicle. Never attempt to adjust the column while driving the vehicle. Doing so could cause loss of vehicle control, personal injury, and property damage.

Windshield Wiper and Washer Controls

NOTICE

Do not attempt to manually move the windshield wiper arms. Wiper motor damage will occur if the arms are forcibly moved.

The windshield wipers and washer controls are on the multi-function turn signal lever on the left-hand side of the steering column. See [Fig. 4.3](#).



09/14/2016

f462301

- A. Pull the steering column locking lever out and away from the column.

Fig. 4.2, Unlocking the Steering Column

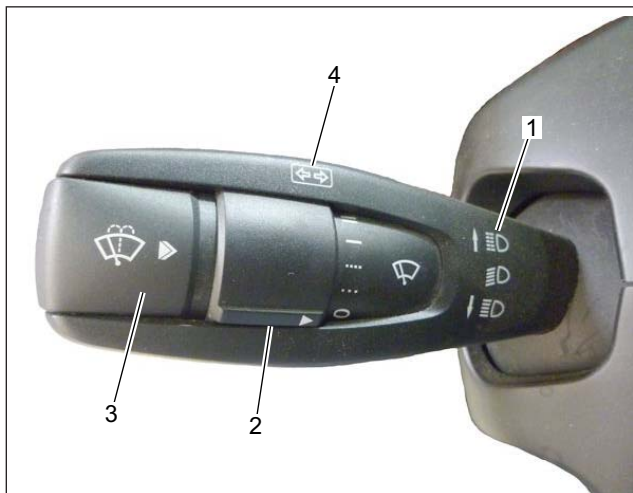

02/17/2017

f611264

- | | |
|------------------------------|------------------------------|
| 1. Headlight Control Symbols | 3. Windshield Washer Switch |
| 2. Windshield Wiper Switch | 4. Turn Signal Symbol Switch |

Fig. 4.3, Windshield Wiper/Washer Controls

Wiper Controls

The wipers are operated by a rotary switch on the turn signal lever. There are five settings: off, two intermittent settings, and two continuous speeds. Symbols mark each setting on the dial.

Turn the wipers on by rotating the rotary switch up. Rotate the switch further to increase the speed of the wipers through the two intermittent settings, then to continuous low and high speeds. Rotate the switch down to slow the wipers down. Rotate the switch as far down as it will go to turn the wipers off.

The default speeds for the two intermittent settings are 6 seconds and 1 second.

The first intermittent setting of 6 seconds is programmable from 1 to 25 seconds. To program the interval, rotate the switch from the first intermittent position to the OFF position, wait for the desired interval between wipes to lapse (between 1 and 25 seconds), and then move the switch back to the first intermittent position. If the switch is kept in the OFF position for more than 50 seconds, the interval changes back to the default of 6 seconds.

The second intermittent setting has an interval of 1 second, and is not programmable.

NOTE: Some vehicles may have a feature that automatically turns on the headlights if the windshield wipers are on and the vehicle is moving faster than 10 mph (16 km/h). At speeds between 10 and 40 mph (16 to 64 km/h), cycling the headlight switch will turn the headlights off.

Wipers and the Rain/Light Sensor

If the vehicle is equipped with a rain/light sensor shown in [Fig. 4.4](#), and the wiper switch is in set to an intermittent setting, the wipers will start when the sensor detects rain or snow.

If the vehicle is moving faster than 40 mph (64 km/h) the wiper speed will automatically increase and decrease, dependent upon how much moisture builds up on the windshield between wipes.

If the wiper switch is set to a continuous speed (low or high), input from the rain/light sensor is ignored.

The behavior of the wipers based on the rain/light sensor input is independent of the headlamp switch position.

NOTE: If a rain/light sensor is installed in the MPC2 bracket, the lens area of the camera will

Driver Controls

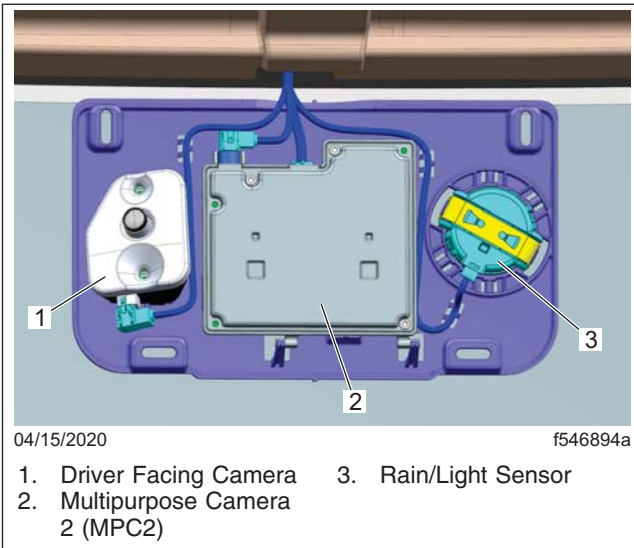

Fig. 4.4, MPC2 Cameras and Rain/Light Sensor

appear shiny when viewed through the windshield because of the silicone gel between the lens and the windshield. If no rain/light sensor is installed, the plastic plug placed in the bracket will appear as a flat black circle.

A vehicle equipped with automatic headlights and an A option on the headlight switch shown in Fig. 4.5, should be equipped with a rain/light sensor.

Windshield Washers

The windshield washer button is located at the end of the turn signal lever. Momentarily press the windshield washer button to initiate a single wipe without activating the washer pump. The wipers will swipe one full cycle and return to the inactive position.

To operate the windshield washers, press and hold the button in. After a short delay, the washer will pump windshield washer fluid onto the windshield for as long as the washer button is pressed. The windshield wipers turn on at low speed while the washer button is pressed. After the button is released, the wipers continue to operate for one to several wipe cycles, depending on how long the wash button was pressed initially.

Exterior Lighting Controls

Unless otherwise noted below, press the upper half of the dash switch to turn the desired light(s) on or off.

Turn Signals

The turn-signal lever is mounted on the left-hand side of the steering column. Pulling the turn-signal lever up activates the right-turn signal; pushing it down activates the left-turn signal. The lever is typically a non-canceling combination turn-signal, windshield wiper/washer switch, and high beam headlamp control unit. See Fig. 4.3.

When a turn signal is activated, a green telltale lamp flashes on the instrument panel.

On a self-canceling turn signal lever, the lever automatically returns to the neutral position when the steering wheel returns to the straight-ahead position after a turn.

Headlamp Switch

The headlamp switch is a rotary switch located to the left of the steering column, above the ignition switch. See Fig. 4.5.

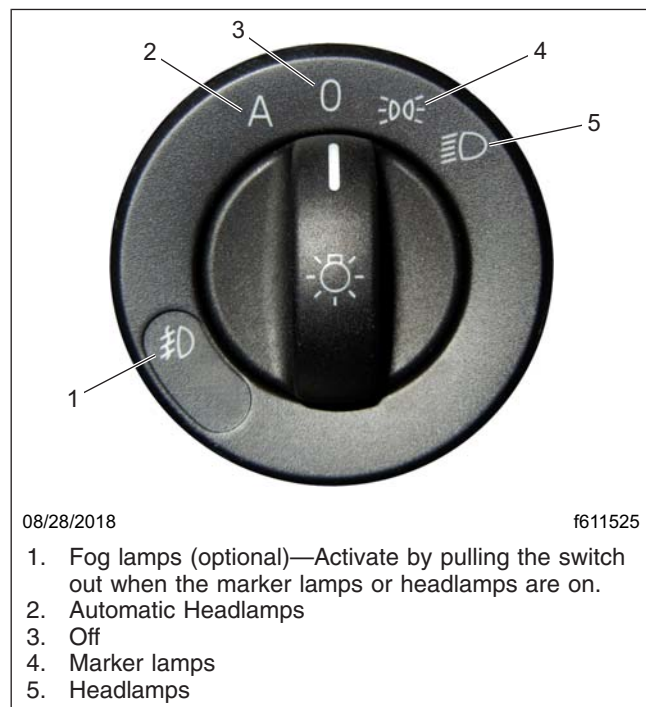

Fig. 4.5, Headlamp Switch

High-Beam Headlamps

With the low-beam headlamps on, push the turn-signal lever away from you to turn on the high-beam headlamps. See [Fig. 4.3](#). To turn off the high-beam headlamps, pull the lever to the middle position.

With the low-beam headlamps on, pull the lever towards you to flash the high-beam headlamps momentarily.

When the high-beam headlamps are on, a blue telltale illuminates on the instrument cluster.

NOTE: The ignition switch must be on for the high beams to work.

Automatic Headlamps

If the vehicle is equipped with a rain-light sensor and the headlamp switch is in the 'A' position, the low beam headlamps and all exterior lamps activate when the outside light decreases to a pre-set level. See [Fig. 4.5](#).

Some vehicles may have a feature that automatically turns on the headlamps if the windshield wipers are on and the vehicle is moving faster than 10 mph (16 km/h). At speeds from 10 to 40 mph (16 to 64 km/h), cycling the headlamp switch turns the headlamps off.

Intelligent High-Beam Headlamps

The intelligent high-beam headlamp feature activates when the headlamp switch is in the 'A' position and the turn signal lever is pushed away from the driver in the high-beam position. See [Fig. 4.3](#) and [Fig. 4.5](#).

When a vehicle approaches from the opposite direction, the high-beam headlamps deactivate and the low-beam headlamps activate. The high-beam headlamps activate again when there are no vehicles approaching from the opposite direction.

Auxiliary High Beam Lamps

If present, auxiliary high-beam lamps are located in the front bumper. To activate the auxiliary high beam lamps, press the upper part of the dash switch. The auxiliary high beam lamps illuminate only when the high-beam headlamps are on. They switch off temporarily when the low-beam headlamps are on, until the high beams are on again. Press the upper half of the switch to deactivate the auxiliary high beam lamps. See [Fig. 4.6](#).

Daytime Running Lamps

If the vehicle is equipped with daytime running lamps (DRL), they are automatically activated when the ignition is switched on and the parking brake is released. The DRL turn off when the engine falls below 400 rpm, the parking brake is applied, or the headlamps are turned on.

Daytime running lamps are mandatory for vehicles domiciled in Canada. Vehicles domiciled in any other location may have an optional override switch. See [Fig. 4.6](#), ref. 3. This is a momentary switch that enables the driver to deactivate the DRL.

Fog Lamps

Fog lamps are designed to reduce glare in foggy conditions. The marker lamps or headlamps must be on in order to turn the fog lamps on. Pull the headlamp switch outward to activate the fog lamps.

Hazard Warning Lamps

The hazard warning lamp switch is located on the dash switch panel. See [Fig. 4.7](#). The hazard lamps can be activated regardless of the ignition switch position.

To activate the hazard lamps, press the center of the switch once. The switch will blink at the same rate that the hazard lamps flash. Press the switch again to turn them off. All the turn signals on the vehicle and trailer, as well as the turn signal indicators in the ICU, flash simultaneously when the hazard lamps are activated.

Marker Lamps

To turn the marker lamps on, turn the headlamp switch clockwise past the off position. See [Fig. 4.5](#).

Marker Interrupt Switch

The marker interrupt switch is located in the right-hand switch pod of the steering wheel for the ICUC system. See [Fig. 4.8](#). Pressing it temporarily flashes the marker lamps.

Pretrip Light Test Switch

When the driver presses the pretrip light test switch, shown in [Fig. 4.9](#), all exterior lights are activated so the driver can exit the vehicle and verify they are working properly. For additional information see [Chapter 22](#) Pre- and Post-Trip Inspections and Maintenance.

Driver Controls

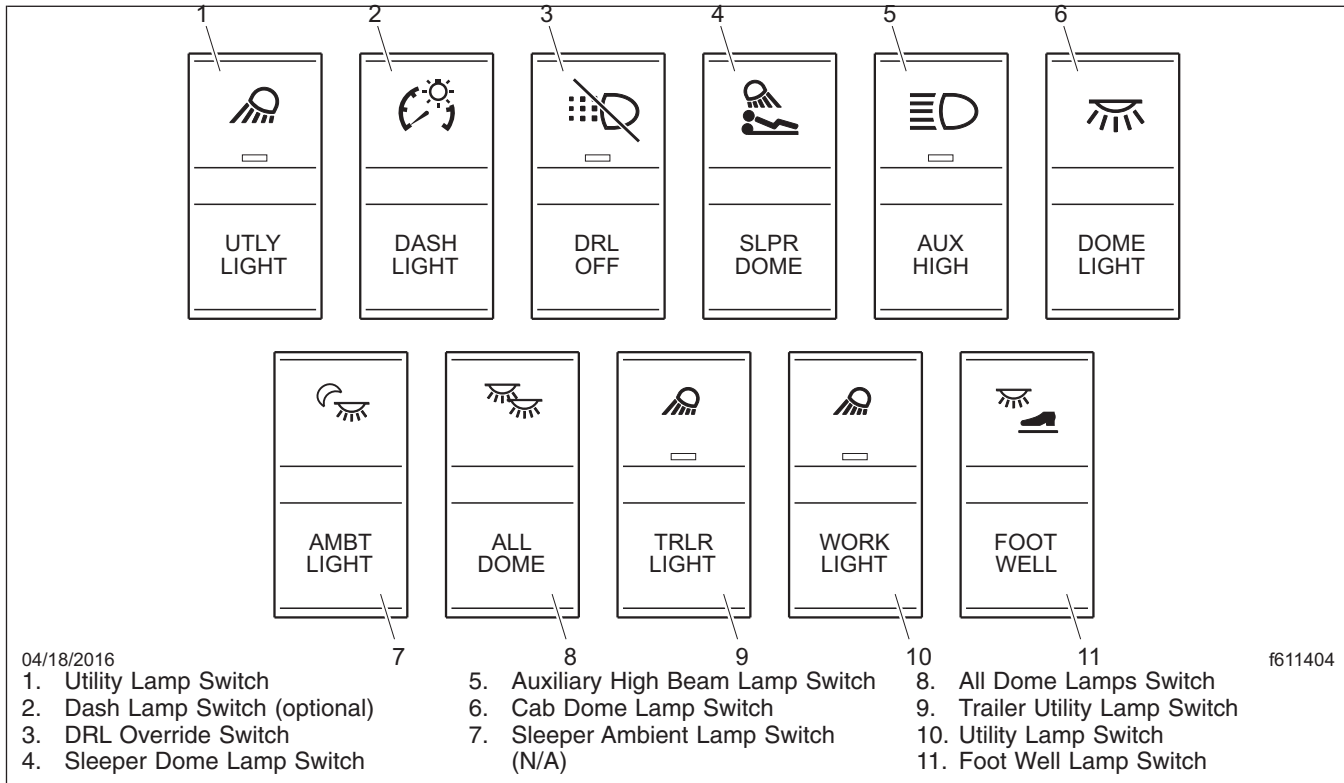

Fig. 4.6, Dash-Mounted Light Switches



Fig. 4.7, Right-Hand Panel Dash Controls

Spotlamp

The spotlamp switch is located on the pivoting handle of the spotlamp. There may be a single

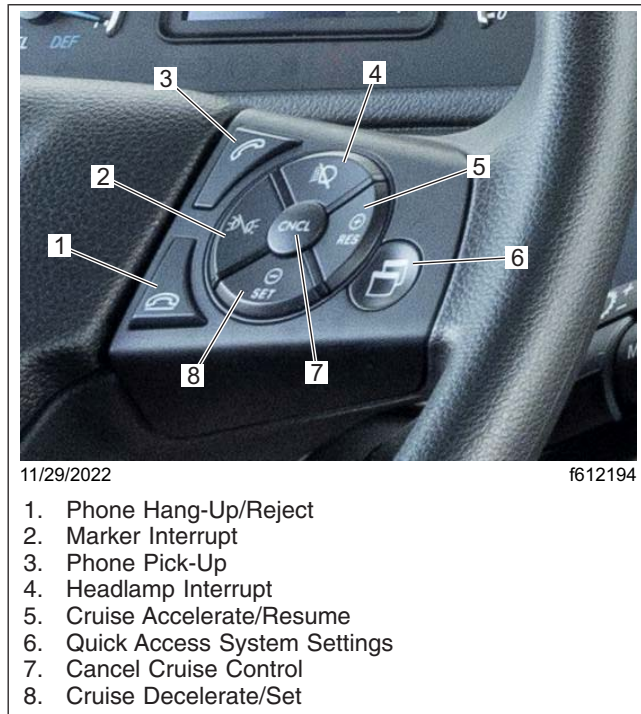

Fig. 4.8, Steering Wheel Right-Hand Switch Pod - ICUC

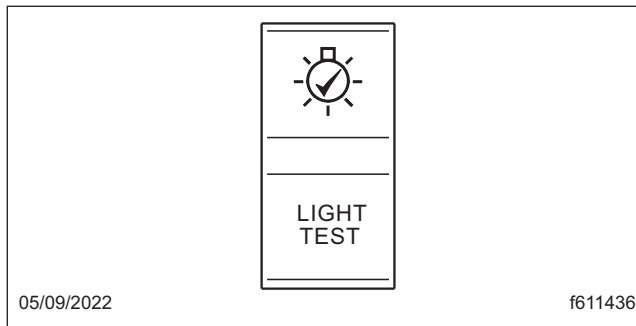

Fig. 4.9, Pretrip Light Test Switch

spotlamp assembly mounted above the driver's door, or one above each door.

Utility Lamps

Utility lamps can be swivel-mounted on the upper half of the cab, mounted on the exhaust support, or flush-mounted on the back of the cab or sleeper. Press the upper half of the switch to turn the utility lamps on or off.

When activated, a red indicator light in the switch is illuminated.

Backup Lamps

Backup lamps activate only when the vehicle is in reverse, and are designed to be used while backing up at night.

Horn Controls

Air Horn

Air horn(s) may be mounted on the roof of day cabs, or under the driver-side floor for sleeper cabs. The air horn is controlled by a wire lanyard that hangs down inboard by the driver's door. See [Fig. 4.10](#). Pull downward on the lanyard to sound the air horn.

Electric Horn

The electric horn is activated by pressing down on the top of the steering wheel center pad.

The horn will sound for the duration that the button is pressed, up to 60 seconds. The electric horn will operate regardless of the position of the ignition key.

Dash-Mounted Brake Controls

NOTE: See [Chapter 11](#) Brake Systems, for additional information about brake systems.



Fig. 4.10, Air Horn Control

Parking Brake Control Valve

The yellow diamond-shaped knob operates the parking brake valve. See [Fig. 4.7](#). Pull the knob out to apply both the tractor and the trailer spring parking brakes. Push both the parking brake and the trailer air supply knobs in to release the tractor and trailer spring parking brakes. Before the spring parking brakes can be released, the air pressure in either air brake system must be at least 65 psi (447 kPa).

If the trailer is not equipped with spring parking brakes, pull the parking brake valve out to apply the tractor parking brakes and the trailer service brakes.

Trailer Air Supply Valve

The red octagonal-shaped knob operates the trailer air supply valve, which charges the trailer air supply system and releases the trailer spring parking brakes. See [Fig. 4.7](#).

After the vehicle and its air hoses are connected to a trailer and the pressure in the air system is at least 65 psi (447 kPa), push the trailer air supply valve knob in (and leave it in) to charge the trailer air supply system and release the trailer spring parking brakes. Pull the trailer air supply valve out before

Driver Controls

disconnecting a trailer or when operating a vehicle without a trailer.

Trailer Brake Lever

The trailer brake lever is used to apply the trailer service brakes without applying the truck or tractor service brakes. It is usually mounted on the right-hand control panel. Move the lever down to apply the trailer brakes; move the lever up to release the trailer brakes. The lever automatically returns to the up position when it is released. See [Fig. 4.7](#). The lever can be partially or fully applied, but in any partially on position it will be overridden by a full application of the service brake pedal.

Antilock Braking System

The Meritor™ WABCO® Antilock Braking System (ABS) passively monitors vehicle wheel speed at all times, and controls wheel speed during emergency stops or wheel lock situations.

During emergency or reduced-traction stops, fully depress the brake pedal until the vehicle comes to a safe stop. *Do not pump the brake pedal.* With the brake pedal fully depressed, the ABS controls all wheels to provide steering control and a reduced braking distance.

The ABS is designed to communicate with a trailer ABS, if they are compatible. Compatibility will result in the illumination of the trailer ABS lamp during vehicle start-up and fault detection. The trailer ABS lamp will not illuminate unless a compatible trailer is connected to the tractor.

Vehicles with ABS may have Automatic Traction Control (ATC). On these vehicles, the ATC system automatically limits wheel spin during reduced-traction situations. In normal braking applications, the standard air brake system is in effect.

Pressing the ATC SPIN switch shown in [Fig. 4.11](#) shuts ATC off and allows drive wheel spin. Pressing the switch again, or cycling the ignition key, cycles the system back to normal operation.

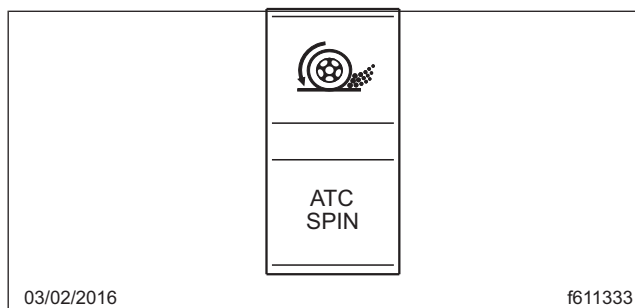

Fig. 4.11, ATC SPIN Switch

Powertrain Controls

Aftertreatment System Regen Switches

NOTE: See [Chapter 13](#) Emissions and Fuel Efficiency, for detailed information about the operation of the regeneration (regen) switches and the aftertreatment system (ATS).

Regen may be started manually with the optional digital switch in the ICU. See [Fig. 4.12](#).

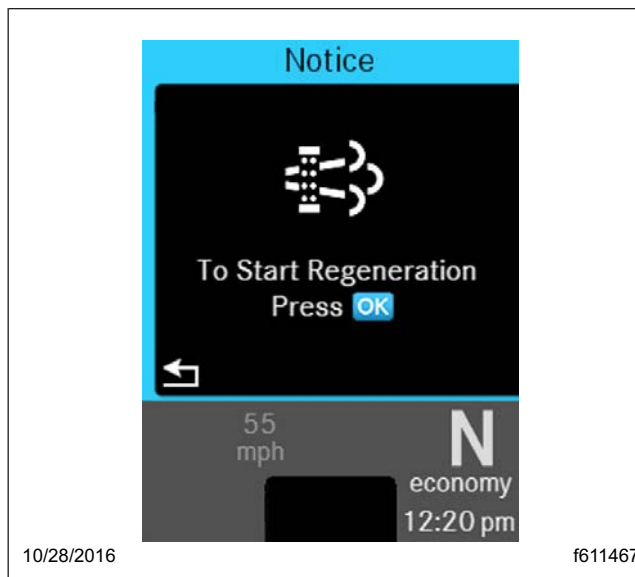

Fig. 4.12, Regen Start Digital Switch - ICUC

NOTICE

The ATC spin feature is intended to be used under specific slippery conditions that require momentary increased wheel spin. Using this option for an extended period of time may damage the vehicle brake system.

Some vehicles may be equipped with a regen inhibit switch. See [Fig. 4.13](#). To stop a regen in progress or prevent the start of a regen, press the upper half of the switch. Regen is delayed until the switch is no longer active.

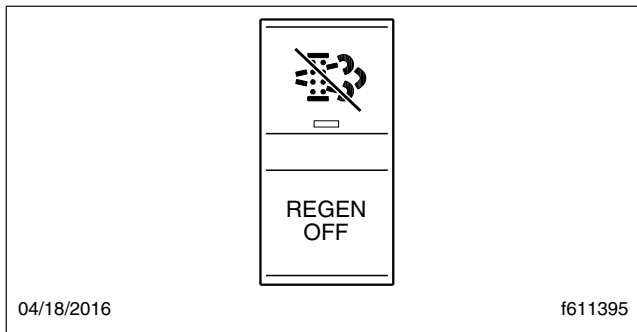

Fig. 4.13, Regen Inhibit Switch

Axle Switches

Some vehicles are equipped with an interaxle differential lock switch and/or a switch for each driver-controlled differential lock (DCDL). See [Fig. 4.14](#).

For more information about differential locks and using them for traction control, see [Chapter 16](#) Drive Axles.

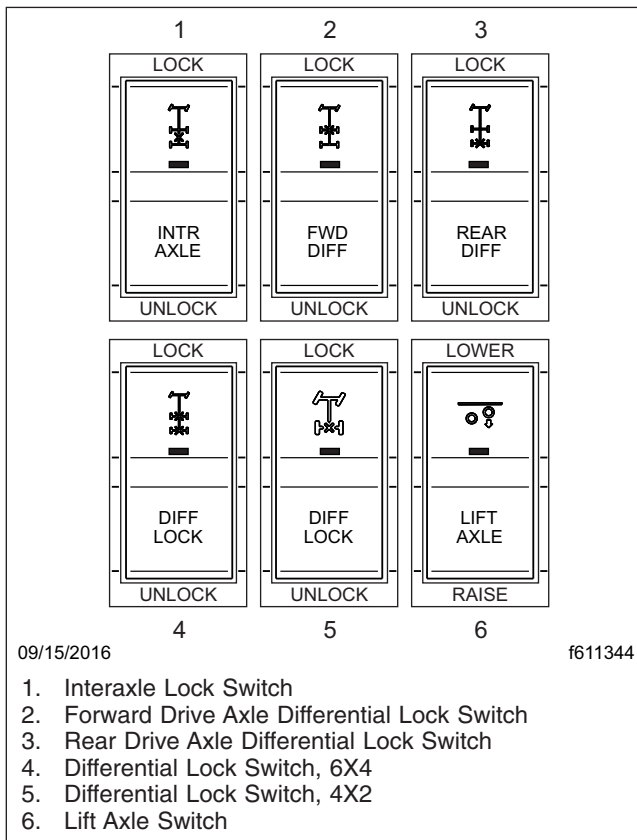

Fig. 4.14, Axle Switches

1. Interaxle Lock Switch
2. Forward Drive Axle Differential Lock Switch
3. Rear Drive Axle Differential Lock Switch
4. Differential Lock Switch, 6X4
5. Differential Lock Switch, 4X2
6. Lift Axle Switch

Engine Brake Switches

NOTE: See [Chapter 11](#) Brake Systems, for detailed information about engine brake operation.

Whenever vehicle braking is required on good road conditions, the engine brake may be used in conjunction with the service brakes. There is no time limit for operation of the engine brake. However, an engine brake does not provide the precise control of, and is not a substitute for, service brakes.

The engine brake control is located on the right-hand steering-column-mounted lever. At the top position, the engine brake is off, and at the three lower positions, the brake is on and the intensity (low, medium, high) increases with each step down. See [Fig. 4.15](#)

NOTE: Cruise control and safety systems may activate the engine brake regardless of the lever position.

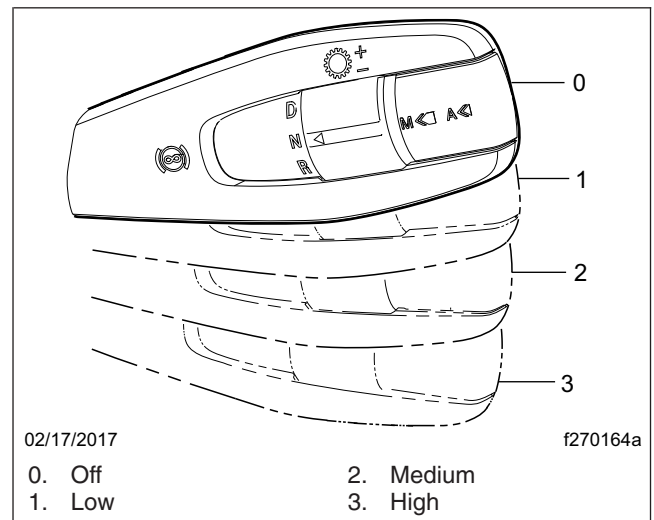

Fig. 4.15, Engine Brake Positions

0. Off
1. Low
2. Medium
3. High

Engine Fan Switch

The engine cooling fan can be turned on by the engine fan switch.

To turn the engine fan on, press the upper half of the switch. The fan will continue to operate for a set amount of time and then turn off unless the coolant temperature is high enough to continue fan operation. To turn the fan off before the set time period ends, press the lower half of the switch. See [Fig. 4.16](#).

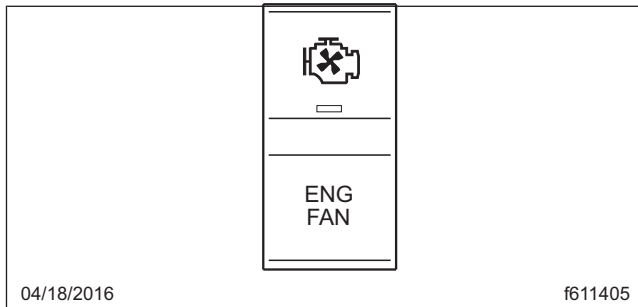

Fig. 4.16, Engine Fan Switch

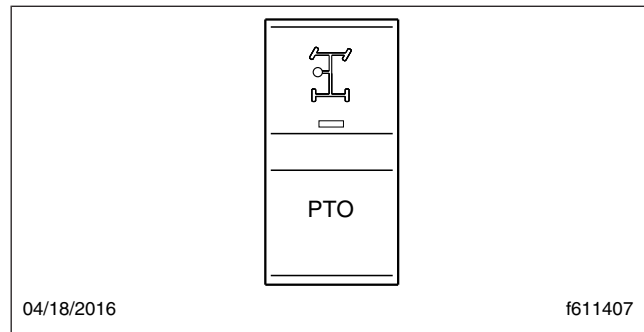

Fig. 4.18, PTO Switch

Hill Start Aid Override Switch

Some vehicles are equipped with a hill start aid (HSA) feature to prevent the vehicle from rolling while on steep grades and to allow for a controlled launch. HSA delays the release of the service brakes until enough torque is available to begin moving the vehicle forward, for a maximum of 3 seconds. HSA is "on" by default. It can be turned off by pressing and releasing the HSA override switch on the dash. See [Fig. 4.17](#).

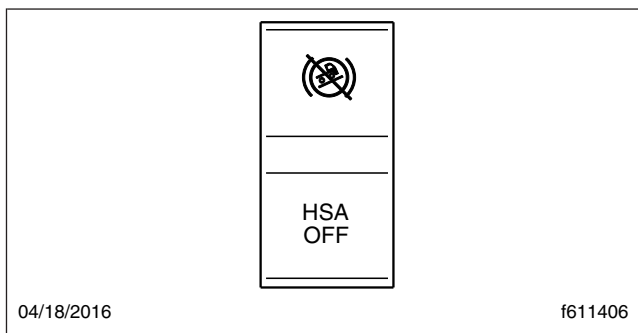

Fig. 4.17, Hill Start Aid Override Switch

Power Take-Off (PTO) Switch

To activate the PTO function, press the upper half of the switch. Press the lower half of the switch to deactivate the PTO function. See [Fig. 4.18](#).

PTO can also be activated using the digital switch in the ICU.

WARNING

To avoid injury, do not install a PTO that is not Detroit Diesel approved onto a Detroit™ Transmission. Use of a non-Detroit Diesel approved PTO with a Detroit Transmission could result in unintended operation which could lead to severe personal injury.

Transmission Controls

Detroit™ Automated Transmissions

NOTE: See [Chapter 14](#) Automated and Automatic Transmissions for automated transmission operating instructions.

Vehicles with automated and automatic transmissions use the multifunction control shown in [Fig. 4.19](#). This control moves in two directions and has two switches. It is used to request manual shifts, change shift mode, set engine brake levels, and control specialty engine brake functions.

Manual Transmissions

NOTE: See [Chapter 15](#) Manual Transmissions and Clutch, for manual transmission operating instructions.

If so equipped, the transmission range control and splitter valves are attached to the gear shift knob.

The range-preselection lever allows the selection of the low or high range for each transmission ratio. It is used once during an upshift sequence and once during a downshift sequence.

Dependent on the transmission model, some ratios can be split using the splitter-control button.

AWD Controls

Front Axle Transfer Case Switch

CAUTION

Stop the vehicle, set the parking brake, and put the transmission in neutral before engaging the front axle. Failure to do so may cause damage to the transfer case and the driveline.

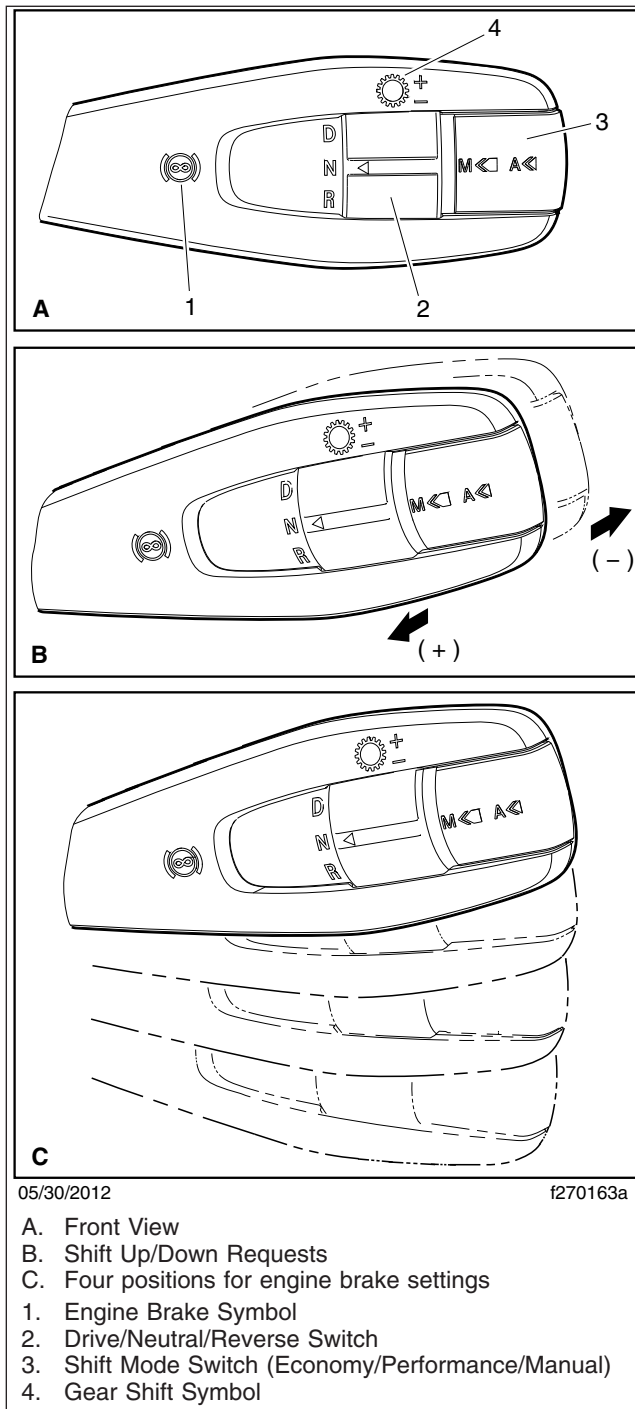

Fig. 4.19, Automated/Automatic Transmission Multifunction Control

The front axle transfer case switch directs power to the front axle. To engage the front axle, press the

upper half of the rocker switch. To disengage it, press the lower half of the switch. See [Fig. 4.20](#).

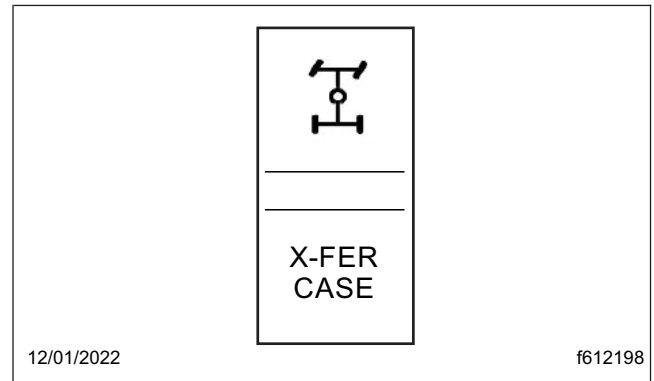

Fig. 4.20, Front Axle Transfer Case Range Switch

Front Axle Transfer Case Range Switch

CAUTION

Stop the vehicle and set the parking brake before selecting the neutral (N) position on the transfer case range switch to prevent the vehicle from rolling, and causing damage and/or personal injury.

Use the range switch when the steering axle has been engaged.

There are two possible transfer case range switches: a two-position rocker switch with LO and Hi range, or a three-position switch that has a third, neutral (N) position, for vehicles with a PTO unit. See [Fig. 4.21](#).

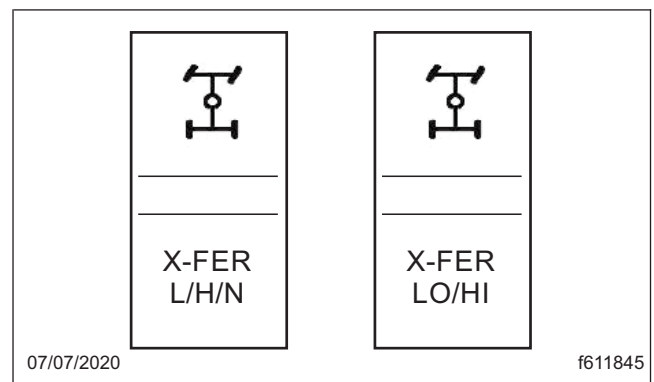

Fig. 4.21, Transfer Case Range Switches

Driver Controls

Other Dash-Mounted Controls

Air Suspension Height Control Switch

NOTICE

Do not operate the vehicle over uneven ground such as ramps, speed bumps, curbs, etc. with the air springs deflated. Doing this may lead to air bag separation from the piston, preventing the suspension air springs from re-inflating.

The air suspension height control switch is used to adjust the vehicle height to aid in coupling or uncoupling from a trailer. See [Fig. 4.22](#). Setting the switch to LOWER deflates the air springs to lower the rear of the vehicle. In the NORMAL position, the air springs inflate to raise the rear of the vehicle to normal ride height.

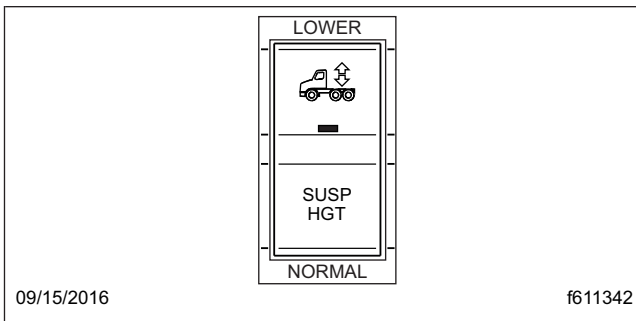

Fig. 4.22, Air Suspension Height Control Switch

NOTICE

Never exhaust air from the suspension while driving. When the air is exhausted, the suspension will not absorb road shocks, and components may be damaged.

A red LED in the switch is illuminated when the suspension is deflated.

5

Cab Features

Cab Amenities	5.1
Interior Lighting Controls	5.2
HVAC Controls	5.3
Infotainment Controls	5.5
Windows	5.7
Mirrors	5.8
Seats - General Information	5.8
Sitting Posture	5.9
ISRI Premium High Back Seat	5.10
ISRI Basic High Back Seat	5.12
Sears C-2 Plus Seat	5.13
Bench Seats	5.14
Seat Belts	5.14
RollTek Rollover Protection System	5.17

Cab Features

Cab Amenities



11/29/2022

f612190

- | | | |
|--------------------------|------------------------|----------------|
| 1. Steering Wheel Pod LH | 4. Trailer Air Supply | 7. Cup Holders |
| 2. Steering Wheel Pod RH | 5. Hazard Lamps Switch | 8. Park Brake |
| 3. Reading Lamp | 6. Power Outlets | |

Fig. 5.1, Dash Features

Standard Features

Standard features include:

- An AM/FM/WB world tuner radio mounted in the dash with Bluetooth®, USB, and auxiliary inputs.
- 12V power outlet in the dash.
- Storage pockets molded into the driver and passenger doors.
- Two cup holders.
- Slot for tablet or phone

Optional Features

Optional features include:

- AM/FM/WB world tuner radio with SiriusXM, iPod interface, Bluetooth, and USB input
- An installed CB radio or wiring for either a overhead or dash mounted CB.
- Two 12V power outlets in the dash or one 12V power outlet and one USB charger
- RAM mounted on dash or overhead console



Fig. 5.2, Tablet Slot



Fig. 5.3, Optional RAM

Interior Lighting Controls

Interior lighting includes dome lamps, console lamps, reading lamps, and courtesy lamps. See [Fig. 5.4](#) for location of the lamps.

Lamps may be controlled using the menu screen of the ICU, dash switches, or by pressing on the lamp lens.

Dash-mounted switches are back lit to illuminate the text and icon on the switch. Press the upper half of the switch to turn the desired lamp(s) on or off. If the lights have a dimming function, hold the switch down to cycle the light between bright and dim.

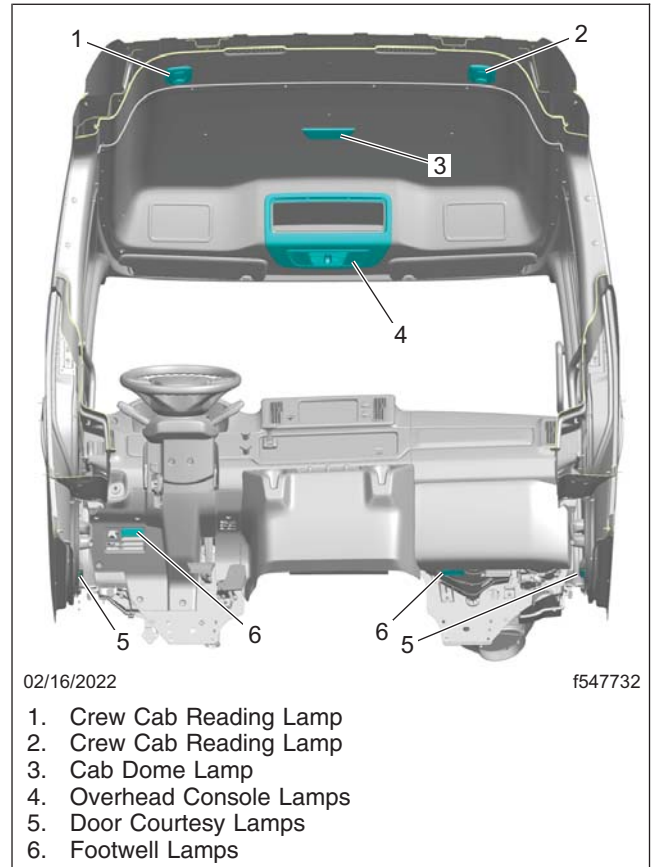

02/16/2022

f547732

1. Crew Cab Reading Lamp
2. Crew Cab Reading Lamp
3. Cab Dome Lamp
4. Overhead Console Lamps
5. Door Courtesy Lamps
6. Footwell Lamps

Fig. 5.4, Interior Lamps

Interior Lights

Door Courtesy Lamps

Each door contains a door entry courtesy lamp located on the bottom of the door pocket that illuminates when the door is opened, and stays on for a short time after both doors are closed.

Foot Well Lamps

If equipped, amber lamps illuminate both foot wells when the driver or passenger doors are opened. These lamps can also be activated with the foot-well light switch, shown in [Fig. 5.5](#).

Cab Dome Lamp

In the day and extended cab, the cab dome lamp is at the midpoint of the cab ceiling; in a crew cab there is a second dome lamp near the cab back wall. The cab dome lamp illuminates when a door is opened and stays on for a short time after both doors are closed.

Cab Features

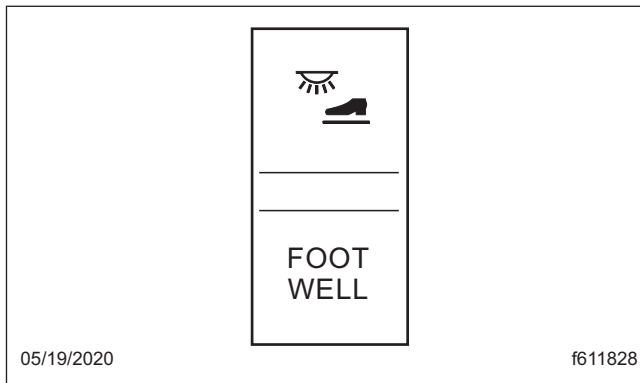

Fig. 5.5, Foot Well Light Switch

Press the lamp cover to turn it off or on.

Overhead Console Lamps

The overhead console lamps consist of two lamps with the form and function of the cab dome lamps, two reading lamps, and an amber lamp that provides ambient light for the center dash area.

The overhead console lights can be individually turned off and on by pressing on the lamp cover.

Dash Lights

The dash lighting adjusts automatically based on ambient lighting.

The brightness can be adjusted in either the 'Settings' menu or with an optional dash light switch as shown in [Fig. 5.6](#).

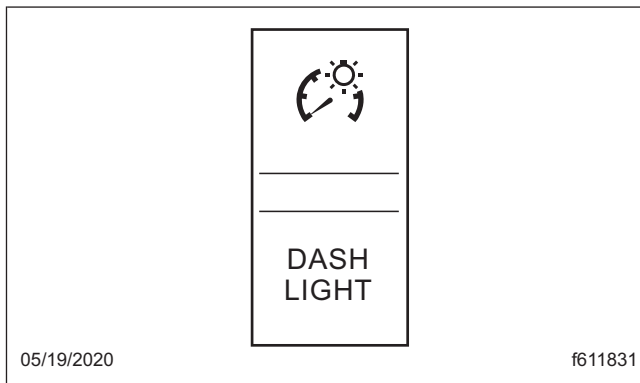

Fig. 5.6, Dash Light Switch

When using the dash light switch, the panel lights brighten and dim in 10% increments, depending on whether the upper half or the lower half of the switch is pressed. When the panel lights are turned on with

the switch they default to the intensity that was last set.

Reading Lamps

An extended or crew cab will have two to three reading lights above the back seat area. Press the switch on the rear of the light to turn it off or on.

Premium Lighting

Some vehicles are equipped with premium lighting which includes theater lighting. Theater lighting refers to the gradual illumination and dimming of the overhead and reading lamps when they are turned on and off.

HVAC Controls

Controls for the heating, ventilation, and air-conditioning system (HVAC) consist of a fan speed switch, an air vent selection switch, and a temperature control switch. On vehicles with air conditioning, the panel also contains a telltale LED and an air recirculation button as shown in [Fig. 5.7](#).

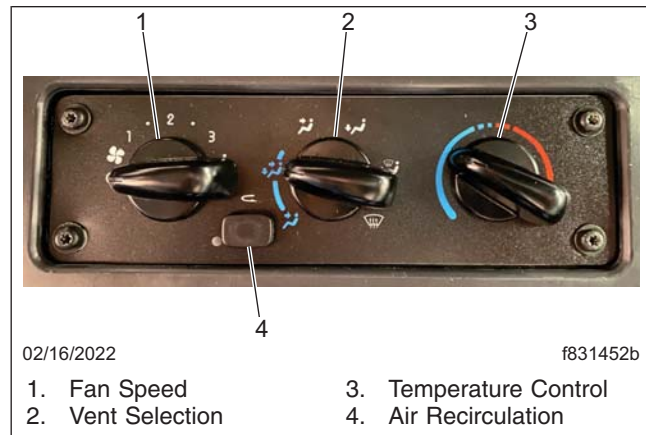

Fig. 5.7, HVAC Climate Control Panel, Standard

Fan Speed Switch

The fan speed switch controls the speed of the fan that forces fresh or recirculated air through the air outlets.

In the default mode fresh, or outside, air circulates through the heating and air conditioning system. If equipped with air conditioning, recirculation mode is available. This limits the amount of outside air entering the cab.

The fan has eight speeds.

Air Vent Selection Switch

The air selection switch allows you to control the flow of air through the face, floor, and defrost vents.

Before using any of the defrost modes, clear the screen at the base of the windshield if snow or ice is present.

With the intermediate modes between each telltale, there are nine modes to choose from on a system without air conditioning, as shown in [Fig. 5.8](#), and eleven modes to choose from in a system with air conditioning as shown in [Fig. 5.9](#).

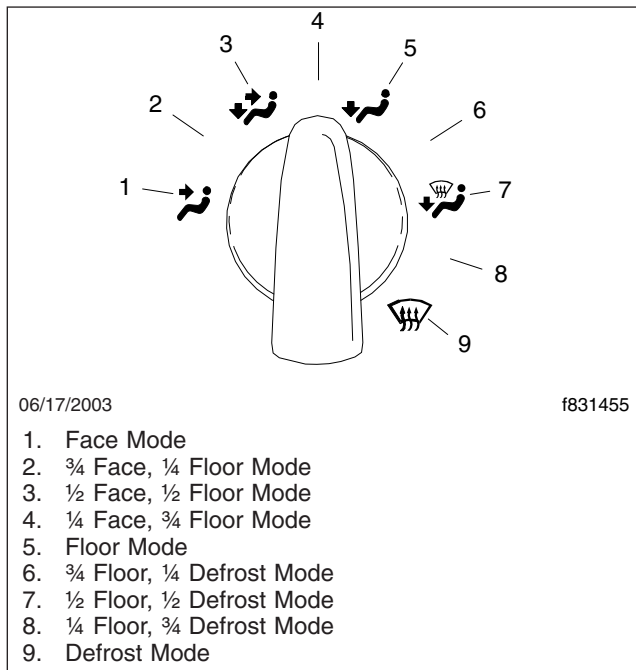

Fig. 5.8, Air Selection Switch Without Air Conditioning

Temperature Control Switch

Turn the switch to the left (counterclockwise) for cool air, or to the right (clockwise) for hot. There are 21 positions on the temperature control switch.

Recirculation Mode

Press the recirculation button to prevent dusty or smoky air from entering the cab or to decrease the time required to cool or heat the cab interior during extreme outside temperature conditions. When recirculation mode is active the LED next to the recirculation button shown in [Fig. 5.7](#) illuminates.

To prevent the buildup of odors or oxygen depletion inside the cab, after 20 minutes the system switches

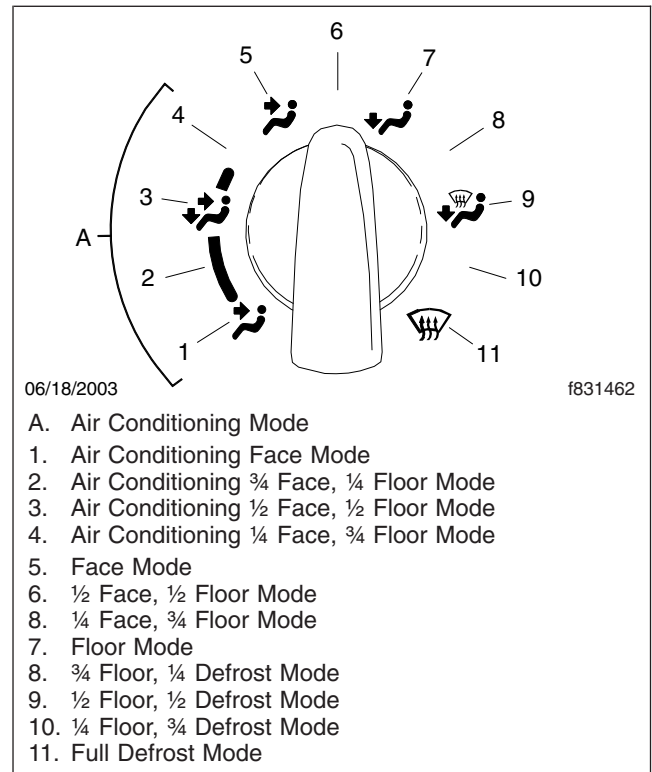

Fig. 5.9, Air Selection Switch With Air Conditioning

from full recirculation mode to partial recirculation mode for five minutes. The system cycles from full to partial recirculation as long as the mode is enabled.

Recirculation mode is not available when the air vent selection is set to partial or full defrost mode.

Air Conditioning

The four air conditioning modes are marked in blue on the air vent selection switch.

IMPORTANT: Operate the air conditioner at least five minutes each month, even during cool weather. This helps prevent drying and cracking of the refrigerant compressor seals and reduces the chance of refrigerant leaks in the system.

NOTE: The heating and air conditioning system has a brushless blower motor with a protection or shutdown mode to prevent damage due to overheating and overcurrent conditions. If the brushless blower motor goes into a protection mode, the motor operates at a slower speed. If the overheating or overcurrent condition continues, the motor shuts down and stops

Cab Features

completely. The motor resumes normal operation after the motor has cooled or the overcurrent condition has been resolved. It is necessary to cycle the fan switch off, and then on, to reset the motor. If the problem appears repeatedly, take the vehicle to a Freightliner dealer or authorized service outlet for repairs.

Infotainment Controls

NOTE: Features of the infotainment system depend on cellular and satellite reception. In certain situations, such as driving through tunnels, mountains, or parked in multistory parking lots, reception may be impaired due to interference or there may be no reception at all.

Safety Information



WARNING

A driver can be distracted from the traffic situation if operating communication equipment integrated in the vehicle when driving, possibly causing loss of control of the vehicle resulting in property damage, physical injury, or death.

Only operate this communication equipment when the road and traffic situation permits, otherwise stop and operate the equipment with the vehicle stationary.

The driver must observe the legal requirements of the country the vehicle is driving through when operating the infotainment system.

Wearing polarized sunglasses may impair or limit your ability to read the display.

General Infotainment Information

The standard infotainment system options consist of AM/FM/WX Radio with USB and auxiliary input with smart phone integration via Bluetooth®.

ICUC Infotainment Screens

Use the menu up and menu down arrows shown in [Fig. 5.10](#) to navigate between the Audio and Telephone infotainment screens:

1. Audio (AM/FM/WX, USB, AUX). See [Fig. 5.11](#).
2. Telephone, showing signal strength, battery level, phone number, and active call length. See [Fig. 5.12](#).

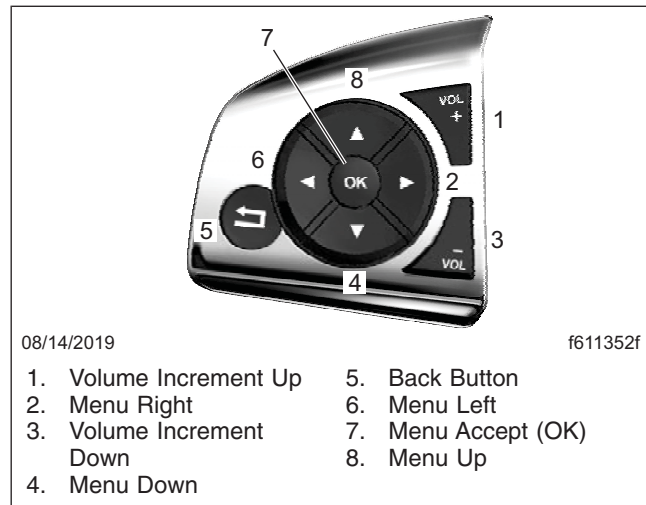

Fig. 5.10, Steering Wheel Left-Hand Switch Pod-ICUC



Fig. 5.11, Infotainment: Radio-ICUC

ICUC Radio Controls

Radio stations, presets, and other audio sources can be accessed under Audio.

1. Select the single bar note icon to open the infotainment menu. The last infotainment menu accessed will open.



Fig. 5.12, Infotainment: Active Call-ICUC

2. If not on the Audio screen, press the Up arrow in the left-hand steering wheel switch pod to move to this screen.
3. Press OK on the left-hand steering wheel switch pod to access Audio Settings.
4. Use the right and left arrows to navigate from one audio source to another—from radio to USB for example.
5. Use the up and down arrows to navigate through an audio options list of choices. Choices can vary depending on the number of audio sources available and saved presets.
6. Press OK on the left-hand steering wheel switch pod to select an audio source. The audio source is selected.
7. Press the back button to return to the main Audio screen.

Physical Radio Controls

ICUC volume up and down switches are on the left-hand switch pod as shown [Fig. 5.10](#). The radio itself also has a volume knob, as shown in [Fig. 5.13](#), which, along with the radio's other physical controls, a passenger would find easier to access.

NOTE: This is a brief overview of DEA710 radio controls; see the owner's manual for a full description.

Phone/Power: Press to show the Bluetooth menu. When a phone is connected, press to accept an incoming call, or long press to display the dial menu.

Display: If the ignition is off, pressing lights up the radio clock for a few seconds; if the ignition is on, pressing changes the source display.

Source/Power: Press to turn the radio on/off and toggle between sources (AM, FM, Bluetooth, etc.). If Bluetooth is active, press to reject/cancel a call.

Volume Knob: Rotate to increase/decrease audio volume, press for less than three seconds to mute audio.

Next/Forward: Press to select the next track/station, press and hold for fast forward.

Previous/Reverse: Press to select the previous track/station, press and hold for fast reverse.

Random: Press to play tracks randomly. Press again to stop.

Repeat: Press to repeat the current track. Press again to stop.

Pause/Play/Mute: Press to pause/unpause a track or mute the current station.

Browse: Press to navigate and play content on an attached device.

Scan/Autoscan: A long press scans stations and stores the six strongest signals to the radio presets until the radio is powered off or the source is changed.

Weather Radio

Weather Radio is an option under the Audio menu.

Weather radio channels WX1 through WX7, corresponding to frequencies 162.400 MHz through 162.550 MHz, are the standard weather radio channels used by NOAA Weather Radio in the United States, Weatheradio Canada/Radiométéo Canada in Canada, and SARMEX in Mexico. Each system consists of a nationwide network of radio stations broadcasting official weather warnings, watches, advisories, forecasts and other non-weather related hazard information including news on natural disasters (earthquakes, avalanches, floods), environmental hazards (oil spills, chemical releases), and public safety messages (AMBER alerts, network

Cab Features

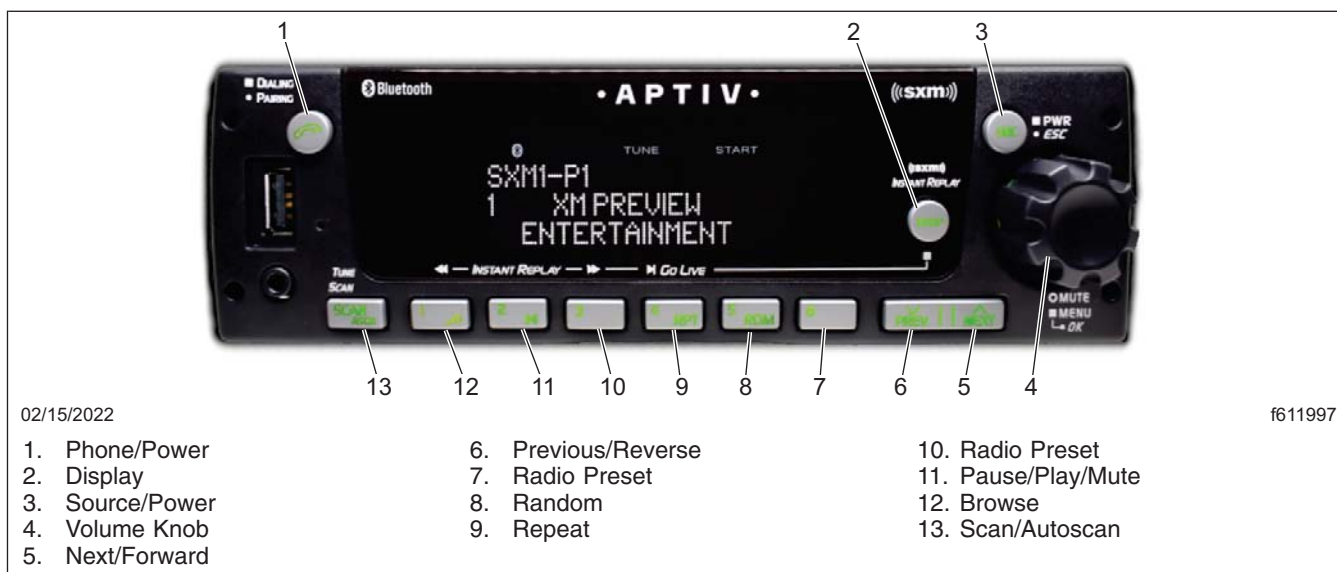

Fig. 5.13, Radio

outages). All services operate 24 hours a day, 7 days a week.

The average range for reception from a transmitter is approximately 40 miles (60 km). The National Weather Service operates more than 1000 transmitters.

Phone Controls

Telephone is the second screen under infotainment. The main telephone screen shows the connected phones current signal and battery strength. If a call is in progress it will show the phone number and call length.

1. Select the single bar note icon to open the infotainment menu. The last infotainment menu accessed will open.
2. If not on the Telephone Screen, use the down arrow in the left-hand steering wheel switch pod to move to this screen.
3. When on the Telephone screen, select OK on the left-hand steering wheel switch pod to access Telephone Settings.
4. Use the right and left arrows to navigate from one telephone setting to another—from contacts to missed calls for example.
5. Use the up and down arrows in the left-hand steering wheel switch pod to navigate through the current Telephone Settings list of choices.

6. Press OK on the left-hand steering wheel switch pod to choose an option.
7. Press the back button on the left-hand steering wheel switch pod to return to the main screen.

Windows

Power windows are standard on M2 Plus vehicles. With power windows, the driver's door has switches mounted in the top of the door, as shown in Fig. 5.14, that separately control the driver and passenger windows. Additionally, the passenger door has a switch mounted in the top of the door that controls the passenger-side power window as shown in Fig. 5.15.

CAUTION

There is no anti-pinch protection when the window is almost closed. Be sure to clear all objects from the window before closing.

The window switches have three positions: lower window, neutral, and raise window. Press forward on the switch to lower the window. Hold the switch down in the forward position for approximately one second to activate the express function; the window will continue to roll down after the switch is released. Press the switch in the rearward position to raise the window.



11/29/2022

f612191

1. Door Lock Switch
2. Driver-Side Window Switch
3. Mirror Heat Switch
4. Mirror Selector Switch
5. Mirror Directional Switch
6. Passenger-Side Window Switch

Fig. 5.14, Driver's Door Switches



11/29/2022

f612192

1. Passenger-Side Window Switch
2. Door Lock Switch

Fig. 5.15, Passenger's Door Switches

Mirrors

The standard outside mirrors are mounted on the door frame. There is a primary heated power rear view mirror and a convex mirror.

The power mirrors are controlled with a left-hand or right-hand mirror selector switch, and a directional switch. Select the left (driver) mirror, or the right (passenger) mirror using the selector switch. The mirror can then be adjusted by pressing the

directional switch arrow for the direction the mirror should be adjusted.

The outside door mirrors can be heated to keep them clear of fog, frost, and ice. To heat the mirrors, press the outboard part of the mirror heat switch on the door. See [Fig. 5.14](#). When the mirror heat switch is on, an amber indicator light on the switch illuminates.

Seats - General Information

General Information

WARNING

Keep hands, tools, and other objects away from the scissor points under the seats. Failure to do so could cause personal injury.

Unless otherwise noted, all seat adjustments should be made while seated and before the engine is started.

Due to the high degree of adjustability found in high-back air suspension seats, it is possible to set the seat back recline adjustment and the seat slide adjustment in such a combination that the seat back will come into contact with the rear wall of the cab. It is the responsibility of the driver to adjust the seat to prevent damage to the seat and the cab interior.

All controls for adjusting air suspension seats are located within easy reach of the occupant.

All adjustment controls for a suspension seat are located on the seat base.

The following is a description of adjustments that are available on one or more seats. Not all seats have all of the adjustments listed below.

1. **Seat Slide (forward-and-backward):** When this adjustment is made, the entire seat moves forward or backward on its track. See [Fig. 5.16](#).
2. **Isolator:** This feature (also referred to as back-slap isolator or Chugger-Snubber®) reduces the amount of road shock by isolating the occupant from the motion of the vehicle, and allowing the upper seat to move in a simple pendulum motion. Whenever the isolator is not desired, it can be locked out. See [Fig. 5.16](#).
3. **Lumbar Support:** Lumbar support changes the shape of the seat back to give more or less support to the occupant's lumbar (lower back) area. This adjustment is either mechanical or air

Cab Features

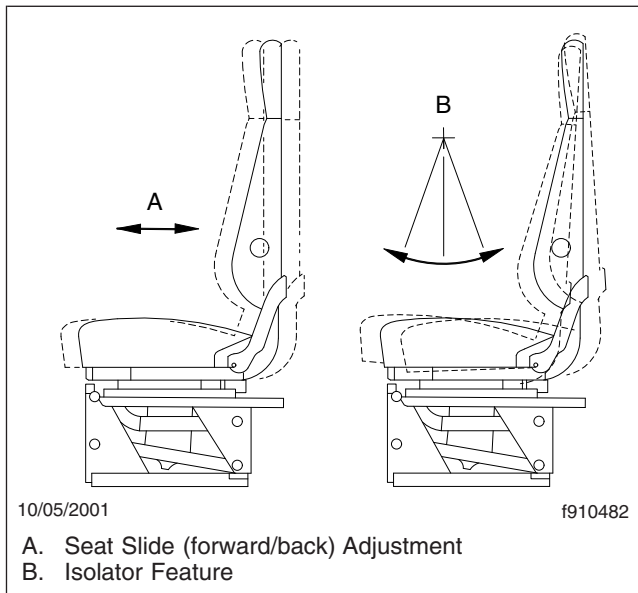

Fig. 5.16, Seat Slide Adjustment and Isolator Feature

controlled, depending on make and model of the seat. See [Fig. 5.17](#).

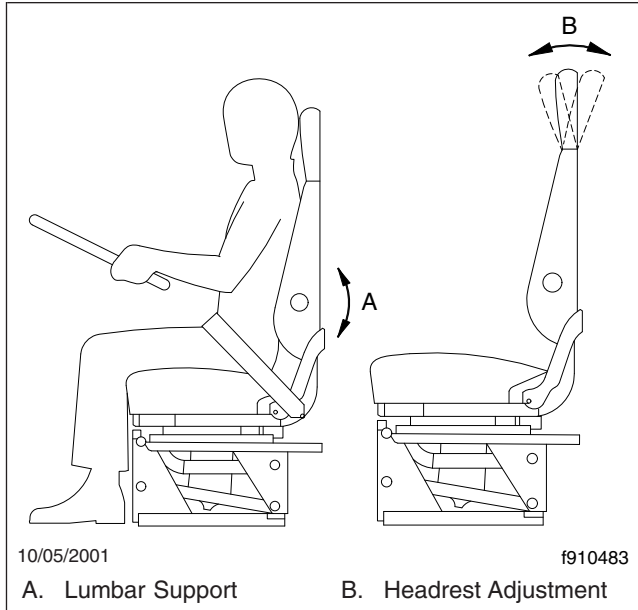

Fig. 5.17, Lumbar Support and Headrest Adjustment

4. Headrest: When this adjustment is made, the upper part of the back cushion changes angle to provide head and upper back support. See [Fig. 5.17](#).
5. Backrest Tilt: This adjustment pivots the backrest forward or backward. See [Fig. 5.18](#).

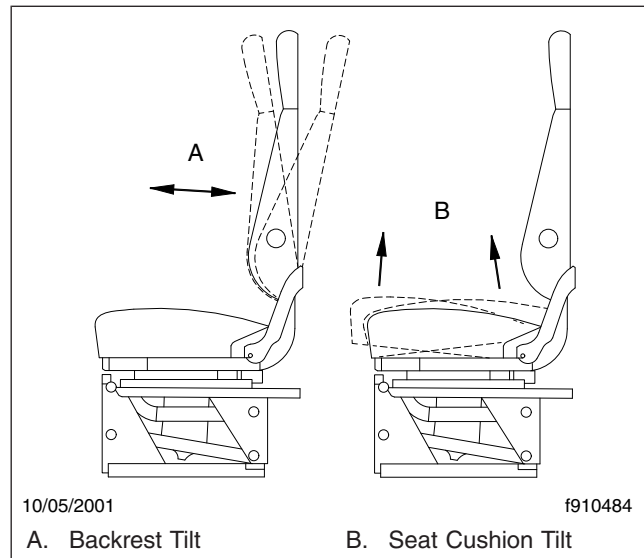

Fig. 5.18, Cushion Tilt Adjustments

6. Seat Cushion Tilt: This adjustment raises or lowers the front and/or back of the seat bottom cushion. This adjustment is easier to perform when all weight is removed from the seat. See [Fig. 5.18](#).
7. Seat Tilt: When this adjustment is made, the seat assembly, both backrest and seat cushion, tilts forward or backward. See [Fig. 5.18](#).
8. Ride Height Adjustment: The entire seat moves up or down when adjusting the ride height. The adjustment is either manual or air controlled, depending on the make and model of the seat. See [Fig. 5.19](#).
9. Damper: While sitting on the seat, a leveling valve sets the seat in the center of the ride zone. When the damper is adjusted properly under normal driving conditions, the seat should not top or bottom against the limits of the vertical travel.
10. Ride Firmness: A firmer ride gives a better feel for the road but less protection against unevenness in the road surface. A softer ride smooths out the bumps.

Sitting Posture

Before driving, adjust the seat to support good sitting posture as shown in [Fig. 5.20](#). Good posture supports the safe operation of the vehicle and the driver's fitness and comfort. When correctly seated, all instruments and controls should be within easy

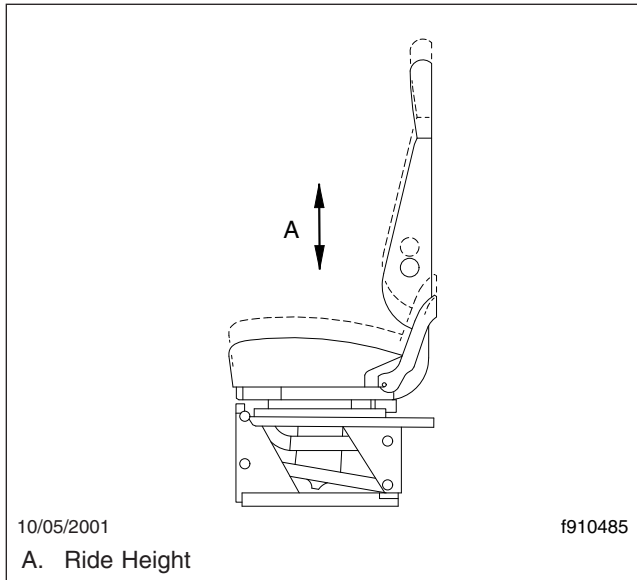

Fig. 5.19, Ride Height Adjustment

reach and the driver should have a clear view of the road and mirrors.

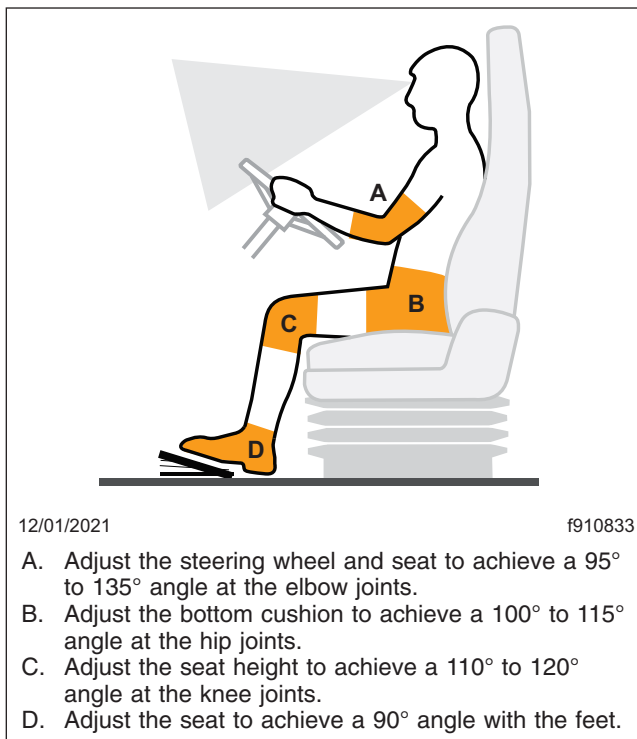

Fig. 5.20, Correct Seating Posture

ISRI Premium High Back Seat

NOTE: The seat should only be adjusted when the vehicle is parked with the park brake on.

The seat is designed to hold a maximum driver's weight of 330 lbs.

The ISRI Premium seat controls are shown in **Fig. 5.21**.

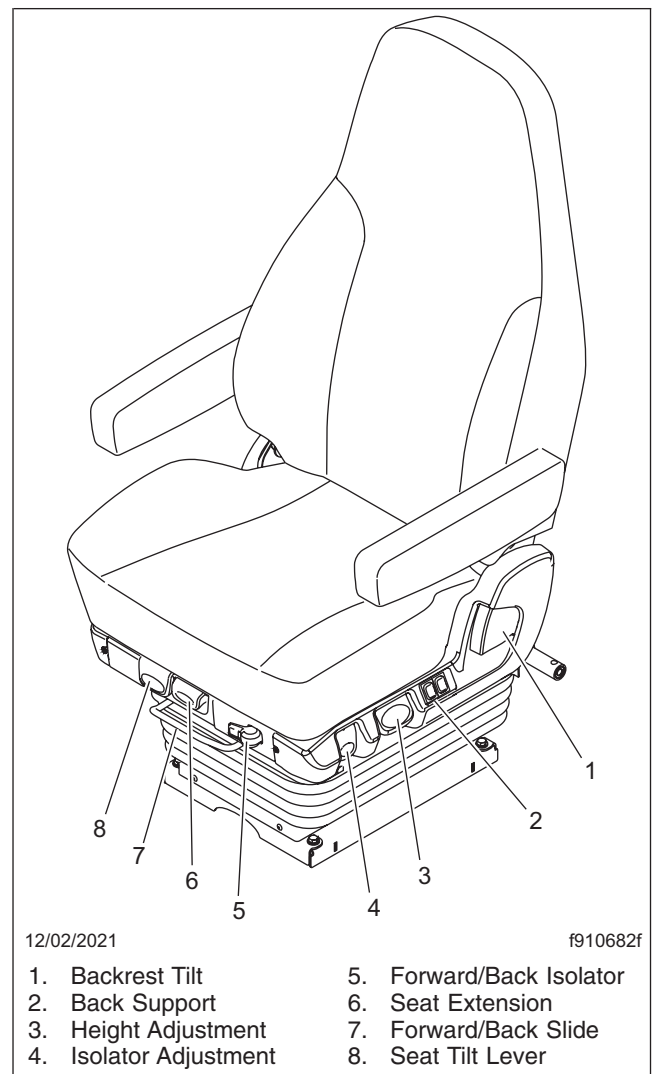

Fig. 5.21, ISRI Premium High Back Seat

1. **Backrest Tilt:** Pull the handle out completely and lean back or forwards to adjust the backrest tilt. Release the handle when the correct position is achieved. The backrest has a 52 degree range of movement.

Cab Features

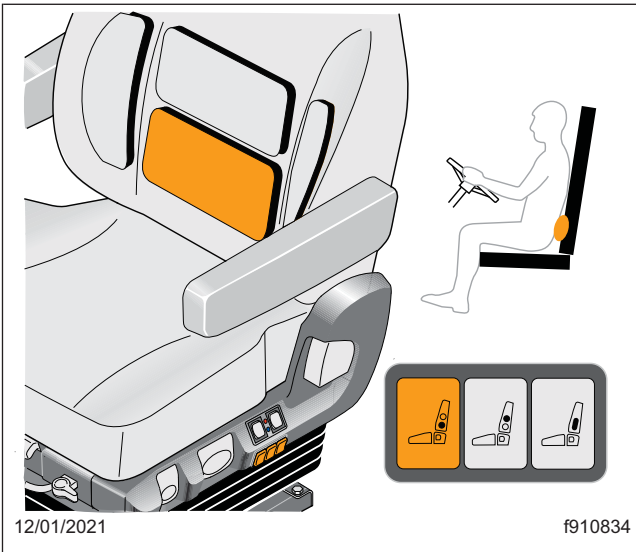

Fig. 5.22, Lower Back Support

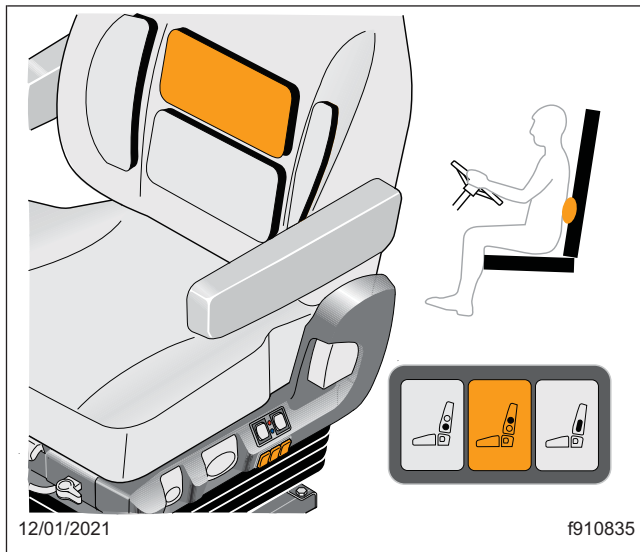

Fig. 5.23, Upper Back Support

When adjusted, the backrest inclination should allow the driver to reach the steering wheel with angled arms.

2. **Back Support:** There are two switches that control the back areas of the seat. Making changes to a driver's sitting position from time to time helps prevent driver fatigue and improves posture.

2.1 Lumbar Support:

Press the forward button to inflate the cushion highlighted in **Fig. 5.22** to increase support at the lower back. This moves the driver's spine into a double S shape and decreases pressure on the spine.

2.2 Upper Back Support:

Press the back button to inflate the cushion highlighted in **Fig. 5.23** to increase support at the mid-back region. This can help prevent the driver from sitting in a slouched, hunched, or hollow-back position.

3. **Height Adjustment:** Pull or push the handle to adjust the seat height.

Adjust the seat so the driver's feet can move each pedal through a full range of motion without fully stretching out the driver's legs or using force.

4. **Damper Adjustment:** Move the lever down to increase damping on rough roads, or up to decrease damping on flat roads.

The damper protects the driver's spine by absorbing vertical vibrations and shocks. It should be adjusted down far enough that the driver's feet never lose contact with the pedals. In general, heavier drivers will not need to adjust the lever up.

5. **Forward/Back Isolator:** Rotate the isolator lever to the left to lock the isolator, or to the right to allow horizontal movement.

Damping horizontal shocks can be helpful with driving off-road or pulling a tank trailer.

6. **Seat Extension:** Pull the lever to move the seat cushion forwards or back. The cushion moves up to 2-3/8 inches (60 mm) in 3/8-inch (10-mm) increments. Releasing the lever locks the cushion in place.

Adjust the length of the seat cushion until there is space for three fingers between the cushion's front edge and the back of the driver's knee. This helps to help improve circulation in the lower legs.

7. **Forward/Back Slide:** Pull the lever to unlock the seat and slide it forward or backward. Release the lever to lock the seat in position.

Adjust the seat so that reaching and pressing the pedals requires no effort and all dashboard controls are within easy reach.

8. **Seat Tilt:** Pull the lever and add or reduce weight on the front area of the seat cushion to move it into one of three positions. Release the lever to lock the seat into position.

The tilt of the seat, along with the tilt of the backrest and the contour of the seat cushion, affects the amount of pressure placed on the underside of the thighs and the back.

9. **Armrest Tilt:** To adjust the armrest angle, tilt the armrest to the highest position, then down to the lowest position, then to the desired position.

The armrest should be at an angle where the elbows lay lightly on it; this helps to relax the muscles in the shoulder and neck.

ISRI Basic High Back Seat

NOTE: The seat should only be adjusted when the vehicle is parked with the park brake on.

The seat is designed to hold a maximum driver's weight of 330 lbs.

The ISRI Basic seat controls are shown in [Fig. 5.24](#).

1. **Backrest Tilt:** Pull the handle out completely and lean back or forwards to adjust the backrest tilt. Release the handle when the correct position is achieved. The backrest has a 52 degree range of movement.

When adjusted, the backrest inclination should allow the driver to reach the steering wheel with angled arms.

2. **Lumbar (Lower) Back Support:**

Press the forward button to inflate the cushion highlighted in [Fig. 5.22](#) to increase support at the lower back. This moves the driver's spine into a double S shape and decreases pressure on the spine.

3. **Height Adjustment:** Pull or push the handle to adjust the seat height.

Adjust the seat so the driver's feet can move each pedal through its full range of motion without fully stretching out the driver's legs or using force.

4. **Forward/Back Isolator:** Rotate the isolator lever to the left to lock the isolator, or to the right to allow horizontal movement.

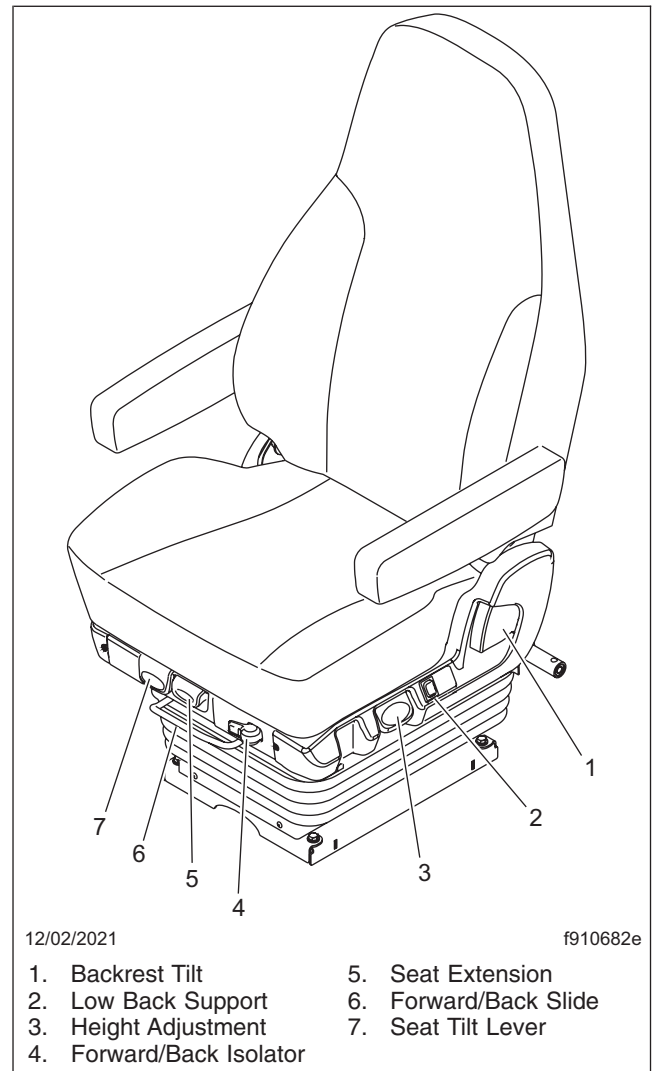

Fig. 5.24, ISRI Basic High Back Seat

Damping horizontal shocks can be helpful with driving off-road or pulling a tank trailer.

5. **Seat Extension:** Pull the lever to move the seat cushion forwards or back. The cushion moves up to 2-3/8 inches (60 mm) in 3/8-inch (10-mm) increments. Releasing the lever locks the cushion in place.

Adjust the length of the seat cushion until there is space for three fingers between the cushion's front edge and the back the driver's knee. This helps to help improve circulation in the lower legs.

Cab Features

6. **Forward/Back Slide:** Pull the lever to unlock the seat and slide it forward or back. Release the lever to lock the seat in position.

Adjust the seat so that reaching and pressing the pedals requires no effort and all dashboard controls are within easy reach.

7. **Seat Tilt:** Pull the lever and add or reduce weight on the front area of the seat cushion to move it into one of three positions. Release the lever to lock the seat into position.

The tilt of the seat, along with the tilt of the backrest and the contour of the seat cushion, affects the amount of pressure placed on the underside of the thighs and the back.

8. **Armrest Tilt:** To adjust the armrest angle, tilt the armrest to the highest position, then down to the lowest position, then to the desired position.

The armrest should be at an angle where the elbows lay lightly on it; this helps to relax the muscles in the shoulder and neck.

Sears C-2 Plus Seat

Seat Slide Adjustment

NOTE: The seat should only be adjusted when the vehicle is parked with the park brake on.

Push the seat slide (forward/back adjustment) lever shown in [Fig. 5.25](#) all the way to the left and slide the seat forward or backward, as desired. Release the lever to lock the seat in the desired position.

Isolator

To engage the isolator (if installed), move the seat slide and isolator lever, as shown in [Fig. 5.26](#), all the way to the right. To lock out the isolator, move the isolator lever to the center position.

Lumbar Support

Move the three-position lumbar support lever upward to increase lumbar support (firmer). Move the lever downward to decrease lumbar support (less firm).

NOTE: This three-position lever (see inset) does not rotate a full 360 degrees.

For seats with air support, use the aft rocker switch on the control panel on the left-hand side of the seat, shown in [Fig. 5.27](#). Press up to make the seat firmer; press down to make the seat less firm.

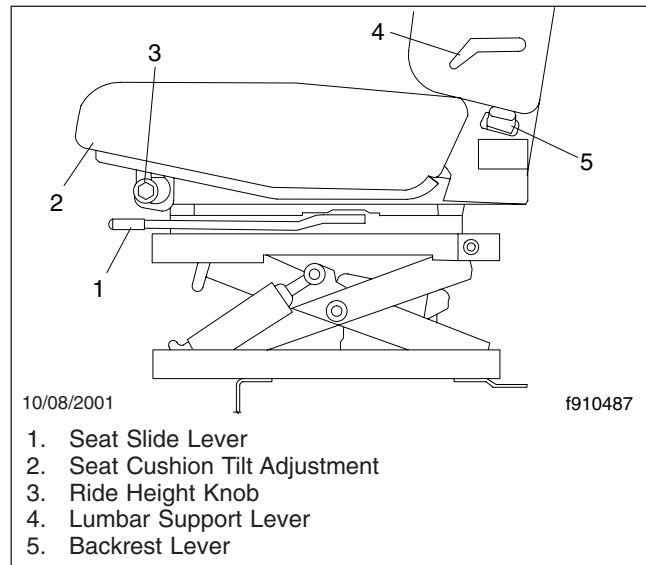

Fig. 5.25, Sears Low Profile Seat

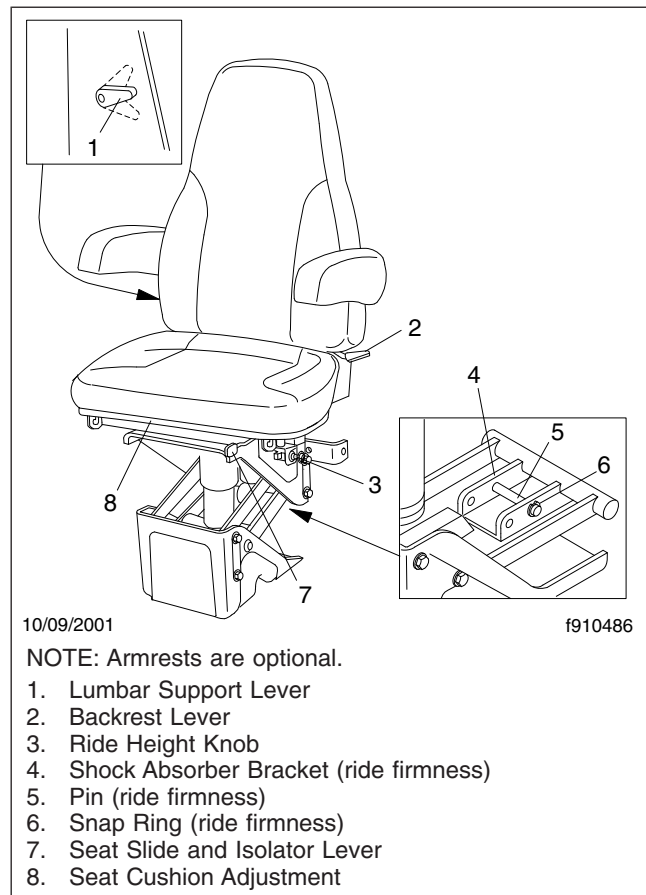

Fig. 5.26, Sears Fleetmaster Seat (with isolator)

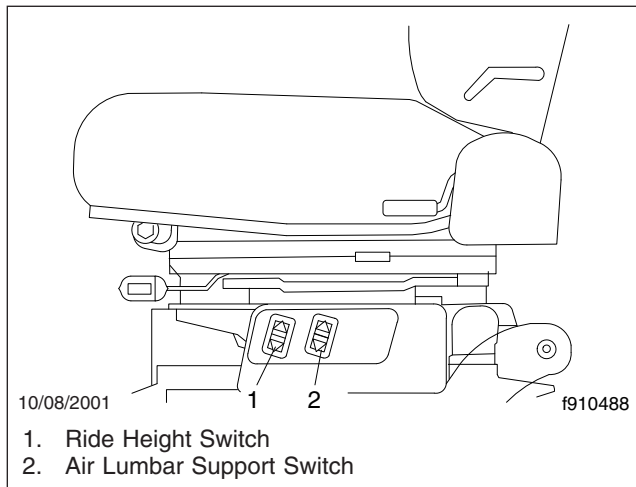

Fig. 5.27, Air Controls, Sears Seat

Seat Cushion Tilt

To raise the seat cushion, lift upward on the front of the seat cushion, and then push it rearwards. To lower the seat cushion, pull forward on the front of the seat cushion, and then push downwards.

Backrest Adjustment

To adjust the backrest, push downwards on the backrest lever just below the bottom of the backrest cushion. With the lever down, lean forward or backward to the desired position. Release the lever to lock the backrest in place.

Ride Height Adjustment

Push the ride height knob inwards to inflate the air cylinder, raising the height of the seat. Pull the ride height knob outwards to deflate the air cylinder, lowering the height of the seat.

For seats with air support, use the forward rocker switch on the control panel on the left-hand side of the seat as shown in [Fig. 5.27](#). Press up to raise the seat; press down to lower the seat.

Ride Firmness Adjustment

For a softer ride, remove the snap ring and pin from the shock absorber bracket (see inset). Relocate the pin in the other set of holes in the bracket and secure it with the snap ring.

Bench Seats

Bench Seats

A full width rear bench seat is optional on the M2Plus. See [Fig. 5.28](#).

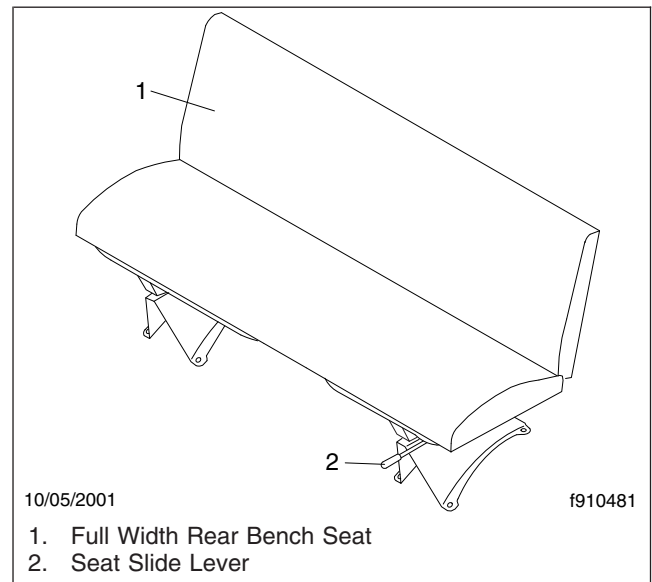

Fig. 5.28, Full Width Rear Bench Seat

The full bench seat accommodates up to three passengers with lap belts and shoulder restraints. The full bench seat has a seat slide adjustment to adjust leg room. Release the seat slide lever and push backwards or forwards to move the seat along its track.

Also available is a two-person bench seat with a safe or tool box located under the seat. No adjustments are available on the two-person bench seat.

Seat Belts

General Information

Seat belt assemblies are designed to secure persons in the vehicle to help reduce the chance of injury or the amount of injury resulting from accidents or sudden stops. For this reason, Daimler Truck North America LLC urges that the driver and *all* passengers, regardless of age or physical condition, use seat belts when riding in the vehicle.

Cab Features

WARNING

Always use the vehicle's seat belt system when operating the vehicle. Failure to do so can result in severe personal injury or death.

Seat belt assemblies in Daimler Truck North America (DTNA) vehicles meet Federal Motor Vehicle Safety Standard 209, "Type 1" and "Type 2" requirements.

When transporting a child, always use a child restraint system or the vehicle seat belts as appropriate. To determine whether a child restraint system is required, review and comply with applicable state and local laws. Any child restraint used must comply with Federal Motor Vehicle Safety Standard 213, "Child Restraint Systems." When providing a child restraint system, always carefully read and follow all instructions pertaining to installation and usage for the child. Make certain the child remains in the restraint system at all times when the vehicle is in motion.

In addition to seat belt assemblies, tether belts are installed on suspension-type seats. Tether belts help secure the seat to the floor and are intended to restrain the seat and seat belt in case of an accident or sudden stop.

IMPORTANT: Seat belts have a finite life which may be much shorter than the life of the vehicle. Regular inspections and replacement as needed are the only assurance of adequate seat belt security over the life of the vehicle.

Seat Belt Inspection

WARNING

Inspect and maintain seat belts. When any part of a seat belt system needs replacement, the entire seat belt must be replaced, both retractor and buckle side. Any time a vehicle is involved in an accident, and the seat belt system was in use, the entire vehicle seat belt system must be replaced before operating the vehicle. Do not attempt to modify the seat belt system; doing so could change the effectiveness of the system. Failure to replace worn or damaged seat belts, or making any modifications to the system, may result in personal injury or death.

Inspect the seat belts and tether belts (if so equipped).

1. Check the web for fraying, cuts, extreme dirt and dust, or for severe fading from exposure to sunlight, especially near the buckle latch plate and in the D-loop guide area.
2. Check operation of the buckle, latch, comfort clip or Sliding Komfort Latch (if equipped), web retractor, and upper seat belt mount on the door pillar. Check all visible components for wear or damage.
3. Check the seat belt and tether belt connection points and tighten any that are loose.

Seat Belt Operation

When engaged and used properly, the comfort clip, as shown in [Fig. 5.29](#) and the Sliding Komfort Latch, as shown in [Fig. 5.30](#) introduce a small amount of slack into the seat belt, resulting in a more comfortable ride.

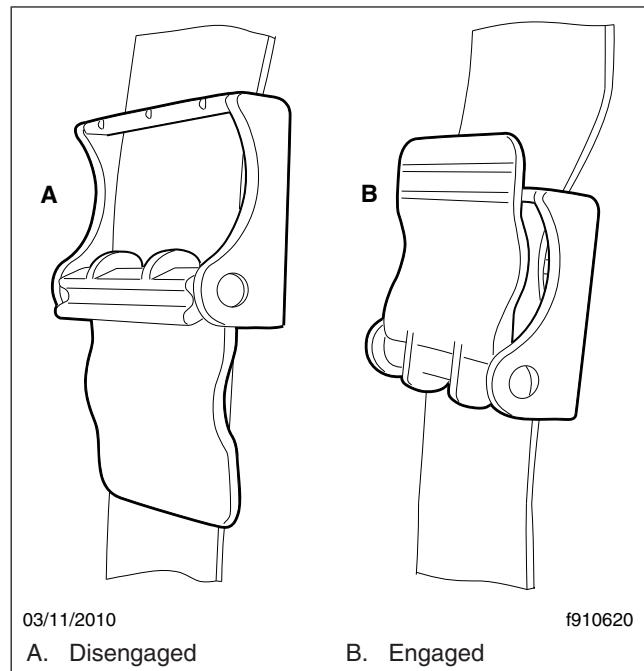

Fig. 5.29, Comfort Clip

1. Slowly pull the latch end of the three-point seat belt out of the retractor and pull it across your lap (from outboard to inboard) far enough to engage the buckle. If the retractor locks too soon, allow the belt to retract slightly, then slowly pull it out again.

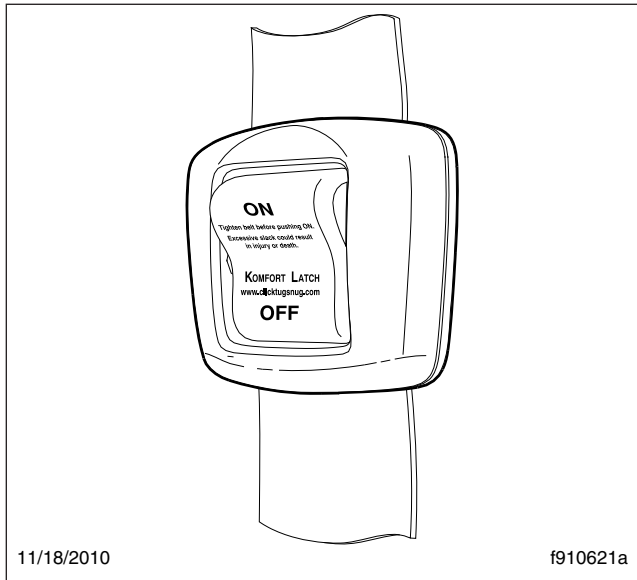

Fig. 5.30, Sliding Komfort Latch

2. Fasten the three-point seat belt by pushing the latch into the buckle. Listen for an audible click. See **Fig. 5.31**.

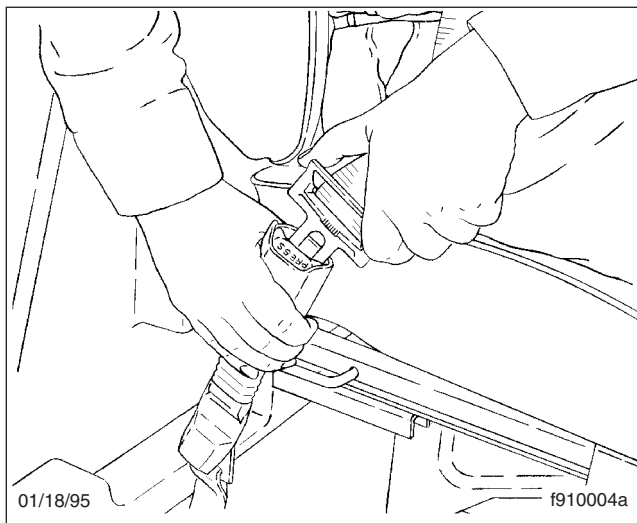

Fig. 5.31, Fastening the Three-Point Belt

3. Tug on the seat belt to make sure it is securely fastened. If the buckle unlatches, repeat this step. If the problem continues, replace the three-point seat belt.
4. Snug the seat belt to your waist.
5. Position the shoulder strap diagonally across your chest with the adjustable D-loop bracket (if

equipped). If desired, engage the comfort clip or Sliding Komfort Latch as follows.

*If equipped with a comfort clip, pull on the shoulder strap to lessen the pressure of the strap on your shoulder and chest. Allow no more than 1 inch (2.5 cm) of slack between your chest and the shoulder harness. More slack can significantly reduce the seat belt effectiveness in an accident or a sudden stop. While holding the belt slack, press the comfort clip lever up, clamping the seat belt webbing as shown in **Fig. 5.32** and **Fig. 5.33**.*

*If equipped with a Sliding Komfort Latch, make sure that the shoulder strap is snug against your chest. Without loosening the shoulder strap, push the Sliding Komfort Latch switch to the "ON" position. See **Fig. 5.30**. To activate the latch lean forward until you hear a click. This will allow for approximately 1 inch (2.5 cm) of slack between your chest and the shoulder harness. Once engaged, the latch will allow you to lean forward about 5 inches (13 cm) without having to reset the latch. Leaning forward more than 5 inches (13 cm) will disengage the Sliding Komfort Latch, requiring it to be reset.*

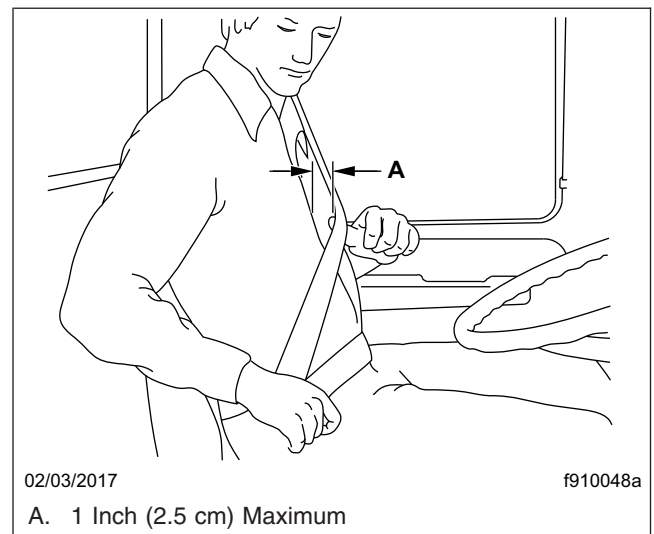

Fig. 5.32, Adjusting Shoulder Harness Clearance, Comfort Clip

6. Unbuckle the three-point seat belt and release the comfort clip or the Sliding Komfort Latch as follows.

If equipped with a comfort clip, unbuckle the seat belt, then release the comfort clip by giving the shoulder belt a quick tug. If you lean forward

Cab Features

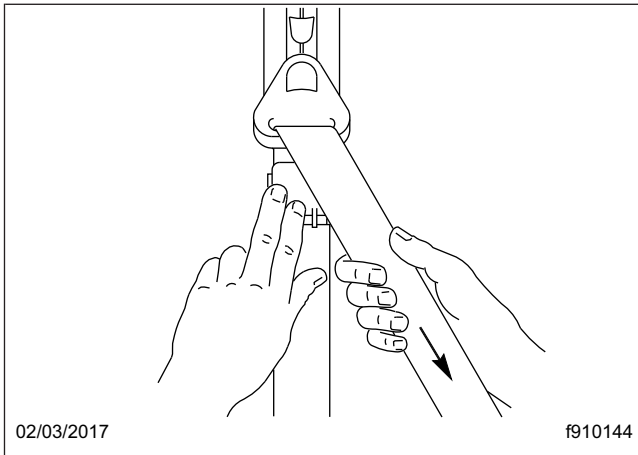

Fig. 5.33, Locking the Comfort Clip

against the shoulder belt, the comfort clip will automatically release, and will need to be reset.

If equipped with a Sliding Komfort Latch, unbuckle the seat belt, then tug on the shoulder belt to release the Sliding Komfort Latch, or press the Sliding Komfort latch to the "OFF" position, then unbuckle the seat belt.

NOTE: Neither the comfort clip nor the Sliding Komfort Latch need to be manually released in an emergency situation. Each will release by itself under rough road or other abnormal conditions. Make sure the three-point seat belt is completely retracted when it is not in use.

RollTek Rollover Protection System

WARNING

Always use the seat belts when operating the vehicle. Failure to do so can result in severe personal injury or death. Do not place infants and children in seats equipped with the RollTek system. The RollTek system is designed for adults only. Doing so could result in severe bodily injury or death. Keep all heavy objects in the cab secured. Do not place objects on the seat back or block the side-roll air bag. Objects that block the side-roll air bag may prevent proper inflation and could result in serious injury or death.

IMPORTANT: The RollTek system must be replaced after being activated. Damaged seat

belts and tethers, or seat belts and tethers that were worn in an accident, must be replaced, and their anchoring points must be checked.

The RollTek system, when used with seat belts, provides additional protection to the driver and passenger (if equipped with a passenger-side system) in rollover accidents. See [Fig. 5.34](#).



Fig. 5.34, Rolltek Seat

The RollTek system provides a significant increase in seat stability during a rollover. Vehicles equipped with RollTek rollover protection have a sensor mounted in the seat base that activates the side-roll air bag and seat pull-down device during a rollover. When the RollTek module senses a rollover, the module triggers gas cylinders mounted in the base of the seat. The gas cylinders activate the power cinches that then tighten the lap and shoulder belts against the occupant of the seat and lower the seat suspension, moving the occupant down and away from the steering wheel and ceiling. The side-roll air

bag deploys from the outboard side of the seat as the seat is pulled down to its lowest position.

The operational readiness of the RollTek system is indicated by the supplemental restraint system (SRS) indicator on the dash. The SRS indicator illuminates for several seconds when the ignition is turned on, and then it goes off. The indicator will remain on if there is a problem with the air bag or RollTek system. The vehicle must be serviced if the SRS indicator does not illuminate when the ignition is turned on, or if the SRS indicator remains on.

 **WARNING**

Keep hands and tools away from the scissor points under the seats. The RollTek system contains components that use combustible chemicals. Do not cut, drill, braze, solder, weld, strike, or probe any part of the RollTek system. Keep all liquids and chemicals away from the RollTek components. Do not attempt to service or modify the RollTek system. Unintentional or improper deployment of the RollTek system could cause severe bodily injury or death. Contact an authorized Freightliner service facility for all service and maintenance.

The air bag module may contain perchlorate material; for information, see www.dtsc.ca.gov/hazardouswaste/perchlorate. Special handling may apply; follow appropriate rules and regulations when disposing of materials.

For all service and maintenance, contact an authorized Freightliner service facility.

6

Detroit Assurance 5.0

Detroit Assurance Collision Mitigation System (CMS)	6.1
Detroit Assurance Vehicle Cameras	6.1
Detroit Assurance Adaptive Cruise Control (ACC)	6.2
Detroit Assurance Tailgate Warning	6.5
Detroit Assurance Active Brake Assist (ABA)	6.5
Limitations of Active Brake Assist and Adaptive Cruise Control	6.7
Detroit Assurance Lane Departure Warning (LDW)	6.11
Detroit Assurance Side Guard Assist (SGA) and Active Side Guard Assist (ASGA)	6.13
Detroit Assurance Traffic Sign Display	6.17

Detroit Assurance 5.0

Detroit Assurance Collision Mitigation System (CMS)

The Detroit Assurance collision mitigation system (CMS) is a safety system that uses a radar mounted on the front frame crossmember, shown in **Fig. 6.1**, and a windshield-mounted multipurpose camera to communicate information to active features that can control the truck.

The system can track vehicles up to 820 ft (250 m) ahead, and if necessary sounds a warning and applies the brakes.

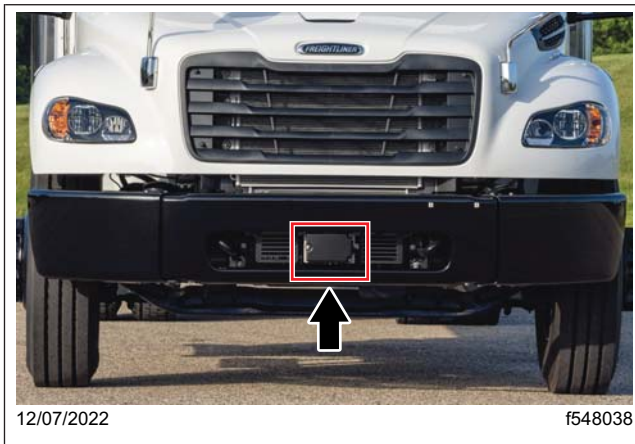

Fig. 6.1, Forward Radar Location

IMPORTANT: Do not mount any attachments in front of the radar distance sensor. Do not paint or affix items over the distance sensor cover. Keep the cover free of mud, ice, and snow. Attachments mounted in front of the distance sensor, such as a crash guard, and objects on the sensor cover can impair the sensor's operation.

Driver's Display

The M2 Plus is equipped with an instrument cluster unit common (ICUC). The driver's display, on the ICUC, presents the status and warnings from the different features that make up the Detroit Assurance safety system.

The standard core features of Detroit Assurance on the Freightliner M2 Plus 106 include active brake assist 5 (ABA5) and lane departure warning (LDW) with a fifteen minute timeout switch.

The standard core features of Detroit Assurance on the Freightliner M2 Plus 112 include active brake

assist 5 (ABA5), adaptive cruise control (ACC) with fixed headway, tailgate warning, and lane departure warning (LDW) with a fifteen minute timeout switch.

Optional safety features include traffic sign display, active speed intervention, and either side guard assist or active side guard assist (SGA).

The right-hand steering wheel switch pod, shown in **Fig. 6.2**, contains adaptive cruise control (ACC) controls and access to Detroit Assurance settings via the 'quick access system settings' button.

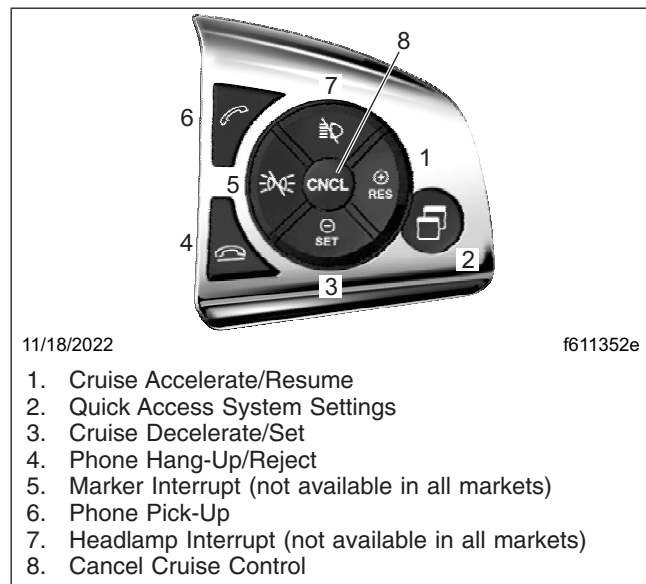

Fig. 6.2, Right-Hand Steering Wheel Switch Pod, ICUC

Detroit Assurance Vehicle Cameras

IMPORTANT: The windshield must be clean, unobstructed, and without damage for the proper operation of the multipurpose camera and rain/light sensor.

Multipurpose Camera 2 (MPC2)

The camera bracket that comes with Detroit Assurance 5.0 can hold a driver facing camera, multipurpose camera 2 (MPC2), and rain/light sensor (RLS). The unit is mounted against the windshield. See **Fig. 6.3**.

The MPC2 works with the radar system to support multiple features within DA 5.0. It is important for the driver to keep the windshield clean and unobstructed in order for the MPC2 and rain/light sensor to operate properly.

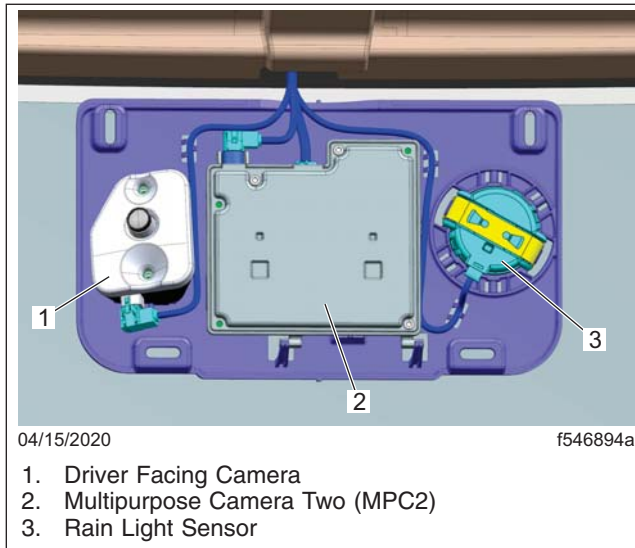

Fig. 6.3, Multipurpose Camera 2 Components

Driver Facing Camera

If equipped, the driver facing camera records the interior view in the case of a safety critical event.

Rain/Light Sensor

This rain/light sensor detects rain, snow, or other precipitation on the windshield and can determine the amount of ambient light.

If the windshield wipers are set to intermittent operation, they automatically start clearing the windshield when the RLS detects precipitation. For additional windshield wiper and headlight information, see [Chapter 4](#).

If the headlight switch is set to the automatic or 'A' position, the low beam headlights and vehicle exterior lights turn on when the RLS registers a low level of ambient light. This could happen due to sunset, fog, smoke, or any other event that decreases light levels.

Bendix Forward Facing Camera

IMPORTANT: In order for the forward facing camera to operate properly, the windshield area in front of the camera must be clean, unobstructed, and not be damaged in any way.

An optional Bendix forward facing 5G camera that works in tandem with the Detroit Assurance MPC2 camera is an available option on the vehicle. If

equipped, the Bendix camera appears as shown in [Fig. 6.4](#).



Fig. 6.4, MPC2 and Bendix Camera Brackets

The Bendix camera records in color and can capture high-quality video in low light conditions. For more information about the Bendix camera, see the SafetyDirect by Bendix section in this chapter.

Detroit Assurance Adaptive Cruise Control (ACC)

⚠ WARNING

The Detroit Assurance Collision Mitigation System is intended solely as an aid for an alert and conscientious professional driver. It is not intended to be relied upon to operate a vehicle. Use the system in conjunction with rearview mirrors and other instruments to safely operate the vehicle.

The Detroit Assurance Collision Mitigation System is not a substitute for safe, normal driving procedures, nor compensate for any driver impairment such as drugs, alcohol, or fatigue.

Failure to drive safely and use the system properly could result in personal injury and/or death and severe property damage.

Adaptive Cruise Control Safety Information

NOTE: In vehicles equipped with a DT12 transmission, this feature is called Adaptive

Detroit Assurance 5.0

Cruise Control to 0 mph. In instances where the feature capabilities are different, this is called out. Otherwise the feature is called Adaptive Cruise Control (ACC).

ACC may not detect vehicles driving in a different lane or narrow vehicles, like motorcycles, driving in front.

In particular, stay aware in the following situations:

- when cornering, entering, and exiting bends;
- when driving winding stretches of road;
- when overtaking;
- when there are vehicles driving in a different lane;
- when vehicles are changing lanes;
- when vehicles are exiting the road;
- when there are obstacles and stationary vehicles.

ACC does not compensate for inattentive driving, weather, or traffic conditions. ACC is only an aid. The driver is responsible for maintaining a safe distance from the vehicle in front, maintaining a safe vehicle speed, braking, and remaining in a lane.

If ACC does not detect a vehicle driving in front, the system accelerates to the set speed.

Adaptive Cruise Control Overview

See [Table 6.1](#) and [Fig. 6.2](#) for a description of cruise control steering wheel switches.

Steering Wheel Controls	
Description	Function
-/SET	Sets the cruise speed while the vehicle is traveling at the desired speed. Pressing and holding decreases the set cruise speed.
+/RES	Resumes the set speed. Pressing and holding increases the set cruise speed.
CNCL	Cancels cruise control, but retains the set speed in memory.

Table 6.1, Steering Wheel Controls

When a vehicle is detected in front, the driver display shows a generic image of the detected vehicle, the detected vehicle’s speed, and the distance to it. See [Fig. 6.5](#).



Fig. 6.5, Driving Assistance ACC, ICUC

Adaptive Cruise Control Functions and Activation Conditions

ACC controls the speed of the equipped vehicle to maintain a safe distance from a vehicle detected in front.

If ACC detects a vehicle in front driving at a slower speed, the engine is defueled, the engine brakes are activated, and the service brakes are applied, slowing the vehicle to maintain the set following distance. The standard factory-set following distance is 3.6 seconds; for vehicles configured with adjustable headway, this can be adjusted under the 'Cruise Control' menu under 'Vehicle Settings.'

In vehicles equipped with a DT12 transmission, ACC to 0mph allows the vehicle to operate in cruise all the way down to 0 mph (0 km/h). As traffic in front of the vehicle slows and eventually stops, the vehicle adjusts with the traffic.

If the vehicle ahead causes the truck to be stopped for two seconds or less, ACC to 0 mph resumes when the vehicle ahead moves. If the vehicle ahead is stopped for more than two seconds, the driver—after carefully checking surrounding traffic—must press the resume button or tap the accelerator pedal to move forward.

The ACC also slows the vehicle if it exceeds the set speed (on a downhill grade, for example).

If there is no vehicle in front, ACC operates in the same way as standard cruise control when the vehicle is traveling above 10 mph (15 km/h).

IMPORTANT: Nothing should be put between the driver and the seat, such as a heating pad, massage pad, or similar items. Doing so may keep the seat occupancy sensor from functioning correctly.

ACC to 0 mph verifies seat occupancy before resuming forward motion after slowing down to 0 mph.

ACC cannot be activated, or is automatically deactivated, if:

- the driver is not in their seat to activate the seat occupancy sensor;
- the vehicle is traveling slower than 10 mph (15 km/h);
- the transmission is in neutral for more than 5 seconds;
- reverse gear is selected;
- the Anti-Lock Braking System (ABS) is deactivated;
- there is a malfunction in the brake system or the electronic management system;
- the distance sensor initialization is not yet complete.

Activating Adaptive Cruise Control and Setting the Speed

Activate ACC by setting the cruise speed, using the controls on the steering wheel. See [Table 6.1](#).

When driving at the desired speed, press the **-/SET** switch to activate ACC and store the set speed.

If cruise control is deactivated, the stored speed can be activated again by pressing the **+ /RES** switch on the steering wheel switch pod. When activated, the driver display shows the adaptive cruise control telltale and the set speed.

If the brake pedal is pressed, ACC is deactivated automatically.

If ACC becomes unavailable, a message appears on the driver display screen. If the vehicle is programmed to allow for standard cruise control, the

message displayed allows the driver to use standard cruise control. See [Fig. 6.6](#).

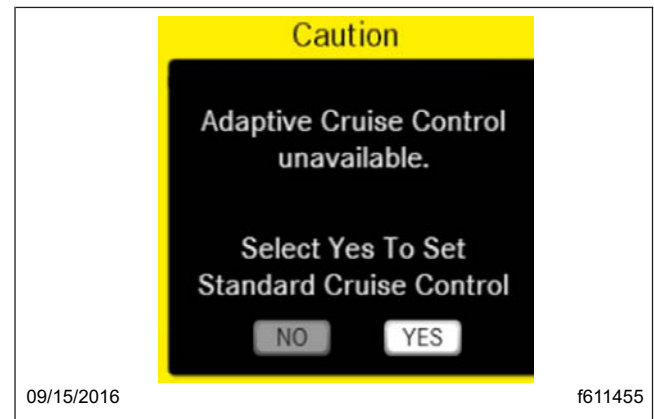

Fig. 6.6, ACC Unavailable Caution, ICUC

Increasing or Reducing Adaptive Cruise Control Speed

The ACC speed setting can only be set when driving.

Press the **-/SET** switch on the steering wheel switch pod to set the cruise speed when the vehicle is traveling at the desired speed. To decrease the set cruise speed, press and hold **-/SET**.

Setting the Adaptive Cruise Control Distance to the Vehicle in Front

If equipped, the ACC ICUC menu under 'Settings' > 'Safety Systems Settings' > 'More Information' > 'Adaptive Cruise Control' can be used to set the overspeed and underspeed limits and the following distance to the vehicle in front.

IMPORTANT: Make sure that the minimum distance required by law is maintained.

Overtaking When Using Adaptive Cruise Control

NOTE: It is possible to exceed the set speed when overtaking.

The set speed of ACC can be exceeded using the accelerator pedal. When the accelerator pedal is released, the ACC set speed is resumed.

Deactivating Adaptive Cruise Control

To deactivate ACC, press the **CNCL** switch on the steering wheel switch pod or press the brake pedal.

Detroit Assurance 5.0

NOTE: The set speed remains stored when ACC is deactivated.

Detroit Assurance Tailgate Warning

The tailgate warning provides alerts when the vehicle in front is being followed too closely.

The system gives warning when:

- ACC is not active;
- the vehicle is moving faster than 20 mph (32 km/h);
- the driver follows a vehicle for longer than 10 seconds at a distance that can be traversed in less than 2.6 seconds.

The system also warns when ACC is active, if:

- the driver is overriding the distance control by pressing on the accelerator pedal;
- the vehicle is moving faster than 20 mph (32 km/h);
- the driver follows a vehicle for longer than 10 seconds at a distance that can be traversed in less than 2.6 seconds.

The system continues to give warnings every 20 seconds if the gap between the vehicles does not increase.

The system does **not** give warning when:

- the vehicle is moving slower than 20 mph (32 km/h);
- another vehicle cuts in front;
- the vehicle in front is moving away;
- ACC distance control is active.

Detroit Assurance Active Brake Assist (ABA)

Active Brake Assist Overview

IMPORTANT: The windshield must be clean, unobstructed, and without damage for proper operation of the multipurpose camera. No objects or attachments should be mounted in front of the forward radar and the radar covering should be free of paint, stickers, mud, ice, or snow.

ABA is active when the vehicle is on.

ABA uses fused camera and radar signals for improved object recognition, enabling it, in some cases, to recognize potential hazardous situations faster than a driver. If the camera cannot positively identify an object, radar signals alone are used. If the camera becomes unplugged or otherwise disabled, ABA is disabled.

ABA tracks both moving and stationary objects in the vehicle's path and, if necessary, engages in a cascade of defensive actions in reaction to those objects through:

1. visual and auditory warnings;
2. then partial braking;
3. then full or emergency braking.

ABA has the capacity to recognize and engage in emergency braking for moving and braking vehicles, moving pedestrians, parked vehicles, and stopped traffic. However, the system will not detect objects or pedestrians in every situation. An ABA equipped vehicle is not a substitute for cautious driving.

Active Brake Assist Safety Information



Active Brake Assist (ABA) is intended only as an aid for a conscientious and alert driver. The driver is responsible for keeping a safe distance from the vehicle in front, for the vehicle speed, braking in a sufficient amount of time, and remaining in the lane.

ABA does not take road and weather conditions into account, nor the prevailing traffic situation. The driver should always adapt their driving to suit road and weather conditions.

The Detroit Assurance Collision Mitigation System is not designed to warn about all possible road hazards. Specifically, it is not programmed to react to animals, oncoming vehicles, or cross traffic, but it may do so.

Operate a vehicle equipped with Detroit Assurance Collision Mitigation System as if the vehicle were not equipped with a collision mitigation system.

Failure to drive safely and use the system properly could result in personal injury and/or death and severe property damage.

A vehicle equipped with ABA may:

- react more quickly than a driver to an object in the vehicle's path of travel;
- perform emergency braking;
- react to moving people with a warning and emergency braking.

ABA may minimize the risk of a front-end collision with a moving or stationary vehicle and pedestrians. If ABA detects the risk of a front-end collision, it issues an audible and visual warning. If the risk persists, ABA automatically initiates partial braking of the vehicle. If the driver does not react to the warnings and partial brake application, ABA automatically initiates a full emergency brake application.

ABA is not designed to detect and react to vehicles driving in a different lane.

ABA may not react to narrow vehicles, like motorcycles, driving in front of the vehicle.

A driver should always be aware of possible hazards and be prepared to engage the service brakes if the ABA system warns of a possible pending collision.

ABA does not automatically adapt to road and traffic conditions. If ABA issues no visual and/or acoustic warning in a critical situation:

- it is suppressed;
- it has failed;
- it has not recognized the danger of the situation.

ABA may also issue warnings where no risk exists. An alert and conscientious driver should be able to easily validate an ABA warning, and, if necessary, override a false-positive ABA braking event.

Activating and Deactivating Active Brake Assist

The M2 Plus has an ABA OFF physical switch option, to support specific operations where an ABA false positive may occur, or conditions where the ABA activation is not required. See [Fig. 6.7](#).

When the ABA function is turned off by the driver the physical switch LED logo illuminates in red, and the ICUC presents a popup warning to the driver showing the ABA not available status. See [Fig. 6.8](#).

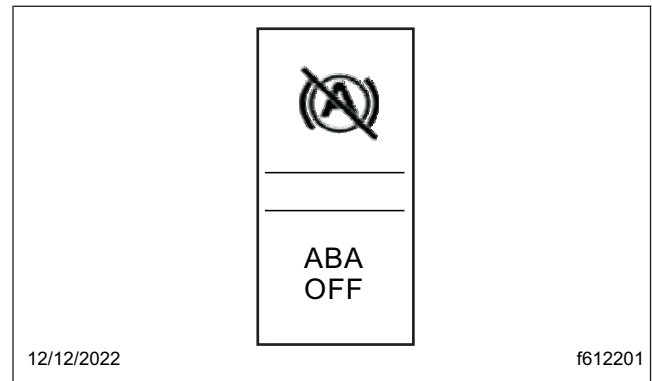

Fig. 6.7, ABA OFF Switch

The ABA will remain off until the driver deactivates the switch, or after a complete key cycle turns the ABA feature back ON.



Fig. 6.8, ABA Not Available Caution

Active Brake Assist Collision Warning and Emergency Braking

NOTE: A driver can override ABA if, during an ABA braking event, the driver presses the accelerator pedal beyond the pressure point (kickdown).

If there is a collision risk, ABA engages in the following cascade of warnings:

1. **Issues Warnings:** the radio and/or hands free system is muted, the vehicle issues a warning beeping, and an ABA collision warning window, shown in [Fig. 6.9](#), appears on the driver display.
2. **Engages in Partial Braking:** ABA brakes the vehicle with around 50 percent of the vehicle's maximum braking power.



Fig. 6.9, First Visual ABA Warning, ICUC

The radio and/or hands free system stays muted, the warning beeping continues, and the ABA collision warning, shown in [Fig. 6.9](#), continues to appear or, if previously dismissed, reappears on the driver display.

- Engages in Emergency Braking:** If a driver does not react to the collision warnings or partial brake application, ABA brakes the vehicle with 100 percent of the vehicle's maximum braking power.

The radio and/or hands free system stays muted, the warning beeping shifts to a continuous tone, and the emergency braking warning, shown in [Fig. 6.10](#) appears on the driver display.

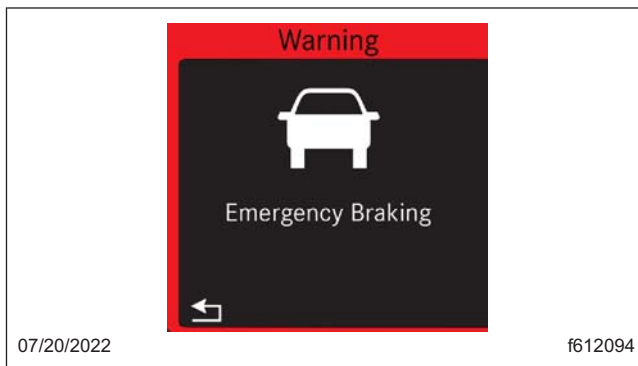

Fig. 6.10, Second Visual ABA Warning, ICUC

- Brakes Release:** The radio and/or hands free system is taken off mute, the warning tone

ceases, and the notice shown in [Fig. 6.11](#) appears on the driver display.

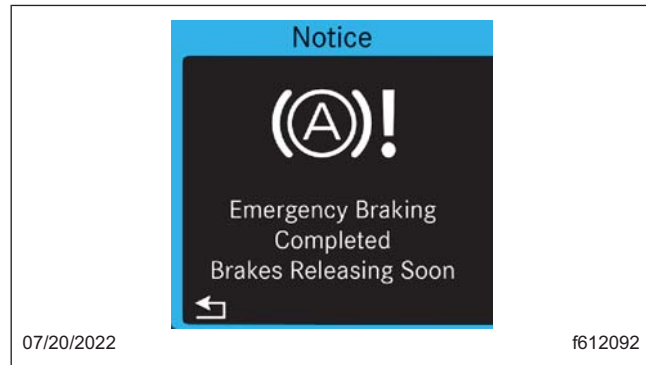

Fig. 6.11, Third Visual ABA Warning, ICUC

The driver should take the first opportunity to safely move the vehicle from traffic. Before continuing, the driver should confirm that the vehicle is in good operating condition and that the load is still properly secured.

CAUTION

After an emergency braking maneuver has been performed, if necessary, move the vehicle from the area of danger.

Take the first opportunity to safely move the vehicle from traffic to confirm the load is still properly secured and that the vehicle is still in good operating order. Failure to do so may result in personal injury and product or property damage

Always apply the parking brake prior to exiting the vehicle.

Limitations of Active Brake Assist and Adaptive Cruise Control

See [Table 6.2](#) for a description of ABA and ACC limitations in specific driving conditions.

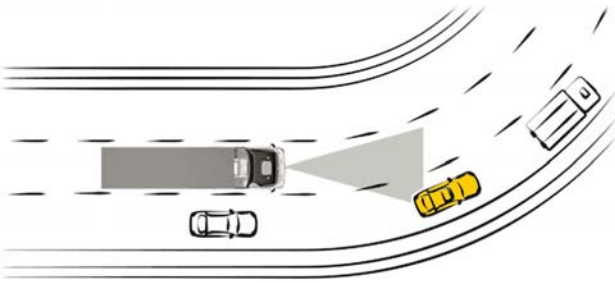
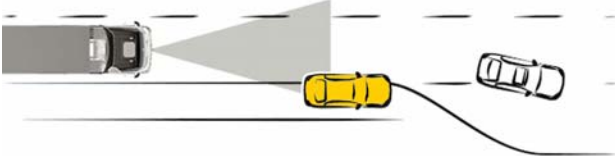
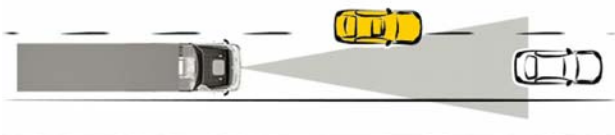
Active Brake Assist and Adaptive Cruise Control Limitations	
Condition and Illustration	Description
<p style="text-align: center;">Cornering, entering and exiting bends</p>  <p>07/27/2022 f040877</p>	<p>The ability of ABA and ACC to react to vehicles on bends is limited.</p> <p>ABA and ACC may react to a vehicle or object in an adjoining lane and unexpectedly issue warnings or brake the vehicle.</p> <p>ABA and ACC may be slow to react to a vehicle or object previously hidden by a bend in the lane.</p> <p>ACC may also accelerate the vehicle unexpectedly if the vehicle ahead is hidden by a bend in the lane.</p>
<p style="text-align: center;">Vehicles not traveling in line with your vehicle and stationary vehicles</p>  <p>07/27/2022 f040883</p>	<p>The ability of ABA and ACC to react to vehicles not traveling in line with your vehicle and stationary vehicles is limited.</p> <p>ABA and ACC may react to a vehicle or object partially in your lane and unexpectedly issue warnings or brake your vehicle.</p> <p>ABA and ACC may be slow or fail to react to vehicles not traveling in line with your vehicle or stationary vehicles only partially in your lane.</p> <p>ACC may not detect and react to vehicles not traveling in line with your vehicle or stationary vehicles partially in your lane and may accelerate unexpectedly.</p>
<p style="text-align: center;">Other vehicles changing lanes</p>  <p>07/27/2022 f040884</p>	<p>The ability of ABA and ACC to detect and react to vehicles pulling into your lane without maintaining a safe distance is limited.</p> <p>ABA and ACC may be slow to react or fail to react to a vehicle entering your lane if the distance to the vehicle entering the lane is too short.</p> <p>ACC may accelerate unexpectedly if it fails to detect the vehicle entering the lane.</p> <p>If a vehicle cuts in front, brake your vehicle to increase the following distance.</p>

Detroit Assurance 5.0

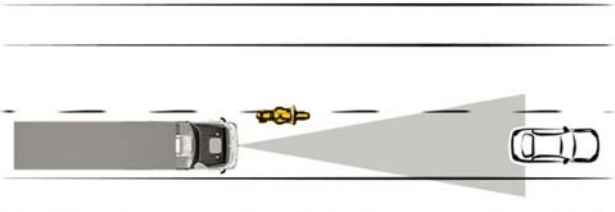
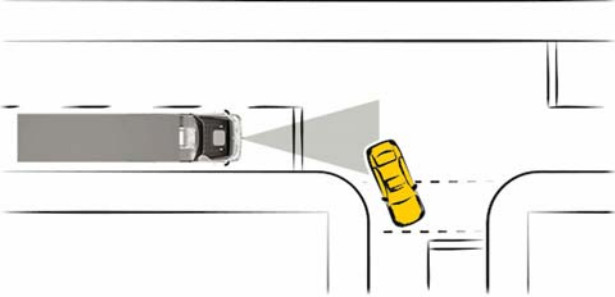
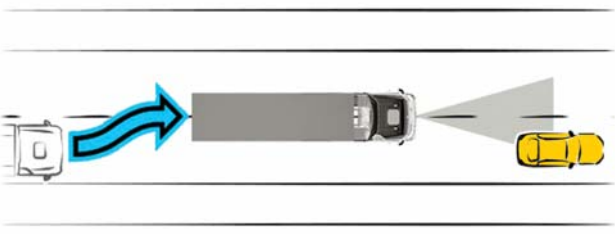
Active Brake Assist and Adaptive Cruise Control Limitations	
Condition and Illustration	Description
<p>Narrow vehicles changing lanes</p>  <p>07/27/2022 f040876</p>	<p>The ability of ABA and ACC to detect and react to narrow vehicles pulling into your lane is limited.</p> <p>Narrow vehicles may be slow to enter the system's detection range.</p> <p>ABA and ACC may be slow to react or fail to react to a critical driving situation due to the merging vehicle being slow to enter the system's detection range.</p> <p>ACC may accelerate unexpectedly if it fails to detect the vehicle entering the lane.</p>
<p>Vehicles turning off or in a nonstandard orientation.</p>  <p>07/27/2022 f040885</p>	<p>The ability of ABA and ACC to detect and react to vehicles turning off or vehicles in a nonstandard orientation is limited.</p> <p>ABA and ACC may react to a vehicle turning off and unexpectedly issue warnings or brake the vehicle.</p> <p>ABA and ACC may be slow or fail to react to a vehicle turning off or to a vehicle at an angle due to an accident even through there is a critical driving situation.</p>
<p>Overtaking</p>  <p>07/27/2022 f040879</p>	<p>The ability of ABA and ACC to detect and react to a vehicle you are overtaking is limited.</p> <p>When overtaking a vehicle, ABA and ACC may unexpectedly issue warnings or brake your vehicle if you drive too close to the vehicle you are overtaking before exiting that lane.</p>

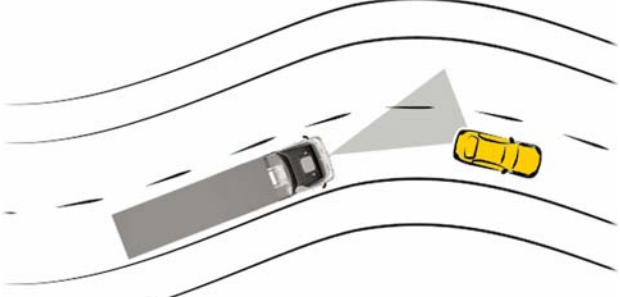
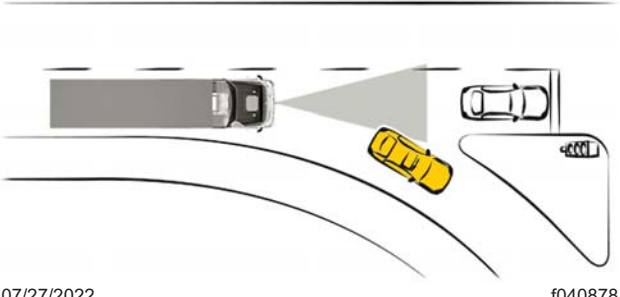
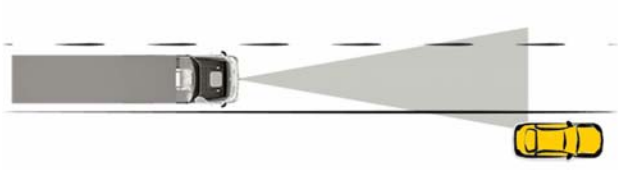
Active Brake Assist and Adaptive Cruise Control Limitations	
Condition and Illustration	Description
<p style="text-align: center;">Winding stretches of road</p>  <p>07/27/2022 f040886</p>	<p>On winding stretches of road, ABA and ACC cannot detect which lane the vehicle in front is driving in.</p> <p>ABA and ACC may unexpectedly issue warnings or brake your vehicle when reacting to vehicles in a different lane.</p> <p>ABA and ACC may be slow to react or fail to react to a vehicle in your lane even through there is a critical driving situation.</p> <p>ACC may fail to detect the vehicle in front in your lane and may accelerate the vehicle unexpectedly.</p>
<p style="text-align: center;">Obstacles and stationary vehicles in front of a detected vehicle</p>  <p>07/27/2022 f040878</p>	<p>The ability of ABA and ACC to detect and react to objects when the detected vehicle turns off is limited.</p> <p>When the detected vehicle turns off, ABA and ACC may react to the obstacle or stationary vehicle that was in front of the detected vehicle and unexpectedly issue warnings or brake your vehicle.</p> <p>When the detected vehicle turns off, ABA and ACC may be slow to react or fail to react to an obstacle or stationary vehicle that was in front of the detected vehicle even though there is a critical driving situation.</p> <p>ACC may react to the vehicle turning off by accelerating unexpectedly.</p>
<p style="text-align: center;">Vehicles parked or broken down at the side of the road</p>  <p>07/27/2022 f040880</p>	<p>The ability of ABA and ACC to detect and react to a stationary vehicle on the side of the road is limited.</p> <p>ABA and ACC may unexpectedly issue warnings or brake your vehicle if it detects a vehicle on the side of the road.</p>

Detroit Assurance 5.0

Active Brake Assist and Adaptive Cruise Control Limitations	
Condition and Illustration	Description
<p style="text-align: center;">Stationary objects</p>  <p>07/27/2022 f040882</p>	<p>The ability of ABA and ACC to detect and react to stationary objects above, beside, and on the road is limited.</p> <p>ABA and ACC can unexpectedly issue warnings and brake the vehicle if it detects stationary objects beside, above, or in front of your lane such as:</p> <ul style="list-style-type: none"> • signs • traffic islands • some bridges, such as truss and cable bridges • low overpasses
<p style="text-align: center;">People</p>  <p>07/27/2022 f040881</p>	<p>The ability of ABA to detect and react to people in certain situations is limited.</p> <p>ABA can unexpectedly issue warnings and brake the vehicle if it detects and reacts to:</p> <ul style="list-style-type: none"> • people on the roadside on a curve • people walking beside the road • people in a tunnel

Table 6.2, Active Brake Assist and Adaptive Cruise Control Limitations

Detroit Assurance Lane Departure Warning (LDW)

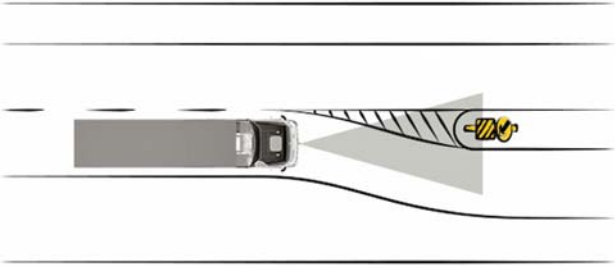
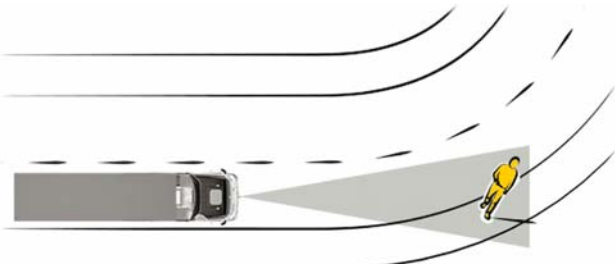

The LDW system is intended only as an aid for a conscientious and alert driver. Do not rely solely on the system to safely operate the vehicle.

The system may not indicate lane departures under certain conditions. Read the information in this manual to understand the circumstances under which this system may not provide adequate lane departure warnings.

The system does not provide warnings for all possible hazards. LDW is not a substitute for safe driving procedures and cannot prevent an accident if the driver is impaired or not driving safely.

Failure to use the system properly could result in personal injury and/or death and severe property damage.

Safety Notes on Lane Departure Warning

The system may be impaired or may not operate in the following situations:

- There is low visibility due to insufficient road illumination, or due to snow, rain, fog, heavy

spray, smoke, or other circumstances that limit visibility.

- There is glare due to oncoming traffic, direct sunlight, or reflections from wet road surfaces.
- The windshield in the area of the camera is dirty, misted up, damaged, or covered by a sticker.
- No lane markings or several varied lane markings are present, such as in a construction zone.
- The lane markings are worn, dark, or covered—such as by sand, dirt, or snow.
- The distance from the vehicle in front is too small and prevents the lane markings from being detected.
- The lane markings change rapidly, such as when lanes merge, branch off, or cross.
- Lanes are very narrow or winding.
- Shade conditions on the road surface vary widely.

The driver must adapt their driving style to current conditions. LDW cannot take the road and weather conditions into account, nor the prevailing traffic situation. The driver is responsible for the distance to the vehicle in front, for vehicle speed, braking in good time, and remaining in the lane.

Overview

LDW monitors the area in front of the vehicle using the multipurpose camera mounted at the top of the windshield. When LDW is active and detecting lane markings, it visually and audibly warns the driver if it thinks the vehicle may be leaving the lane unintentionally.

LDW only needs one identifiable lane line to function.

Functions and Activation Conditions for Lane Departure Warning

The Detroit Assurance LDW system is designed to warn the driver as the vehicle crosses the outer boundary of the lane marking. This may differ from other LDW systems which issue a warning as the driver approaches the inside of the lane marking. If the system warns at, or just beyond the outer edge of the lane marking, the system is performing as designed. If the warning does not occur, or occurs

after an excessive lane departure, the system may not be operating properly.

Lane departure warning only issues warnings if the speed is above approximately 37 mph (60 km/h).

The lane markings on the driver display screen show the status and state of LDW:

- No lane markings indicate that LDW is off.
- Outlined lane markings indicate that LDW is not ready.
- Solid white markings indicate LDW is on and ready to issue warnings.
- Red lane markings indicate a lane departure is occurring; red lane markings are a visual warning from the LDW system.

In addition to the visual warning, when driving over lane markings unintentionally, the volume of audio equipment like the radio and/or hands-free systems is muted and a "rumble-strip noise" emits from the side of the vehicle driving over the lane markings.

LDW does not issue an audible warning when:

- the turn signals are switched on
- if the driver is braking or accelerating
- if the driver is making a sharp turn
- if a driving safety system such as ABA5, stability control, or ACC intervenes.

Activating or Deactivating Lane Departure Warning (LDW)

When the engine is turned on, LDW is automatically activated.

NOTE: There is no audible self-test of the "rumble-strip noise" of LDW when the key is turned on.

Pressing the physical LDW OFF switch deactivates LDW for fifteen minutes. See [Fig. 6.12](#). When LDW is deactivated, the switch illuminates.

A driver might want to turn off LDW on winding roads or when driving through construction zones or other areas where lane markings are not clear.

LDW is not active if:

- the driver presses the LDW OFF switch;
- the system is searching for a lane.

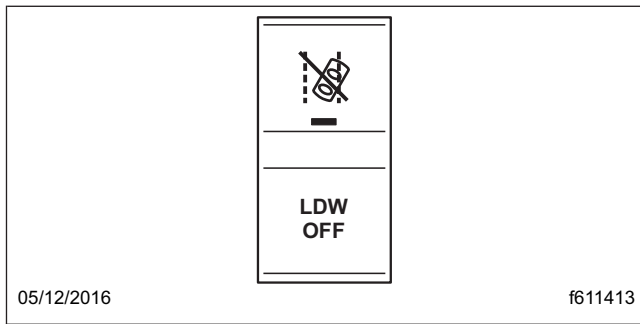

Fig. 6.12, Lane Departure Warning Alert Switch

If there is a system error, the LDW unavailable telltale, shown in **Fig. 6.13**, illuminates on the driver display.



Fig. 6.13, LDW Unavailable Telltale, ICUC

Cleaning the Windshield in the Area of the Camera

Make sure that the windshield is always kept clean and unobstructed in the area of the camera.

During rainy or cold weather, the driver should switch on the windshield wiper to clear the windshield and remove snow and ice to avoid incorrect lane detection.

If the area of the windshield is damaged, LDW may not work as intended. If this happens, the windshield must be replaced.

Detroit Assurance Side Guard Assist (SGA) and Active Side Guard Assist (ASGA)

General Information

IMPORTANT: SGA is designed for use with one trailer attached to the tractor. The enhancement, ASGA, only reacts to moving objects within SGA's sensor monitoring area.

SGA detects if a trailer is attached to the tractor, but it cannot detect whether or not multiple

trailers are attached. If used with more than one trailer, SGA only considers objects or stationary obstacles in the range of the tractor and the first trailer. False-positive indications and warnings may occur with multiple trailers.

IMPORTANT: SGA and its enhancement, ASGA, are not currently designed to work with non-ABS trailers or on trucks with lift axles.

In a left-hand drive vehicle, SGA monitors the area to the right of the vehicle and trailer using two short range radar sensors. The radar sensors are mounted close to the rear of the right-hand footsteps. See **Fig. 6.14**. SGA provides assistance when turning right and changing lanes to the right. A triangular warning lamp in the A-pillar, shown in **Fig. 6.15**, lights up to inform the driver that an object has been detected in the monitored area. An additional warning tone sounds if there is a risk of collision.

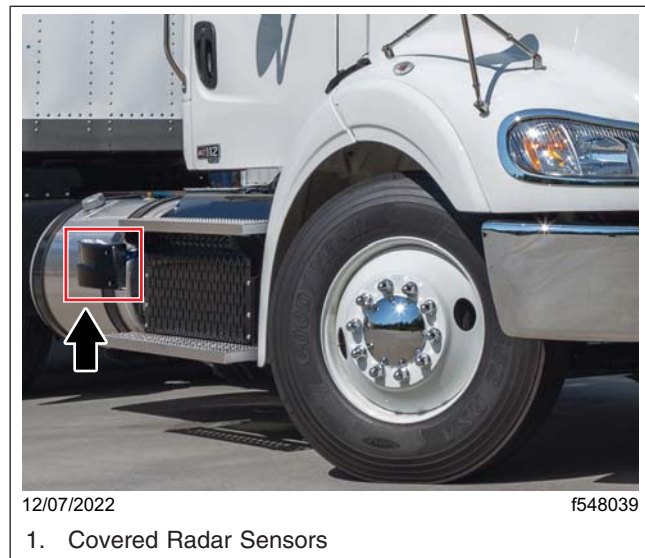

1. Covered Radar Sensors

Fig. 6.14, Radar Sensors with Covers

ASGA engages at speeds less than 12 mph (19 km/h). If SGA detects a critical moving object in the sensor monitoring area along the side of the truck during a passenger side turn, ASGA automatically applies the brakes.

In a right-hand drive vehicle, SGA monitors the area to the left of the vehicle and trailer. The location of sensors and warning lamps on the vehicle all shift to the left in this case. All other features remain the same.

The trailer monitoring of SGA is not active shortly after reversing or coupling up; therefore it is not



Fig. 6.15, SGA Warning Lamp

possible to switch SGA trailer monitoring on or off shortly after reversing or coupling up.

Safety Information



When detection is restricted, SGA may issue a warning too late or not at all. The detection of obstacles can be impaired by the following situations:

- dirty, icy or obscured sensors
- very wide lanes
- vehicles not driving in the middle of their lane
- barriers or other road boundaries

There is a risk of an accident in these situations.

The driver must pay attention to the traffic situation and maintain a safe distance at the side of the vehicle.

SGA is only an aid for a conscientious driver. Depending on the situation and the trailer, SGA may issue a warning prematurely or not at all. SGA is not a substitute for attentive driving. Always ensure there is sufficient distance to the side for other vehicles, cyclists, pedestrians, and obstacles.

IMPORTANT: If the sensors are dirty or SGA malfunctions, a grey triangle alert icon appears on the driver display. Objects in the monitoring range are not tracked when this occurs.

Before driving the vehicle, ensure the radar sensor cover is free from dirt, ice, or slush. If the sensors get dirty while driving, pull off in a safe location to clean them. The radar sensors must not be painted or covered by items such as stickers.

If the vehicle is involved in a severe accident or there is damage to the right-hand footsteps, have the function of the radar sensors checked.

If SGA malfunctions, have the function of the radar sensors checked at an authorized dealer.

SGA is only an aid for a conscientious driver. Depending on the situation and the trailer, SGA may issue a warning prematurely or not at all. SGA is not a substitute for attentive driving. Always ensure there is sufficient distance to the side for other vehicles, cyclists, pedestrians, and obstacles.

Sensor Monitoring Range

As shown in Fig. 6.16, there is an empty angle of approximately 6 degrees between the vehicle and the area monitored by the sensor. Objects within this area are not detected.

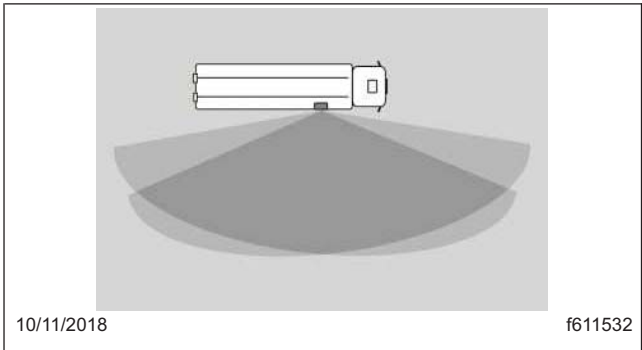

Fig. 6.16, Sensor Monitoring Area

Due to the nature of the system, warnings may be issued in error when driving close to barriers or other solid boundaries.

Warnings may also be interrupted when driving alongside particularly long vehicles for a prolonged time.

SGA Indicator Lamps

NOTE: Depending on the type of instrument panel installed in the vehicle, the telltales described as grey may appear white.

Name	Telltale	Color
Side Guard Assist Initializing		Grey
Side Guard Assist Active		Grey
Side Guard Assist Error or Deactivation		Grey
Side Guard Assist Trailer Monitoring Active		Grey
Side Guard Assist Trailer Monitoring Deactivated		Grey
Caution, Side Guard Assist		Amber
Caution, Side Guard Assist Trailer		Amber
Caution, Side Guard Assist Trailer Monitoring Deactivated		Amber
Warning, Side Guard Assist		Red
Warning, Side Guard Assist Trailer		Red
Warning, Side Guard Assist Trailer Monitoring Deactivated		Red

Table 6.3, Side Guard Assist Telltales

Activating or Deactivating the Side Guard Assist

SGA becomes active when the ignition is turned on. An SGA initializing telltale, the first telltale in [Table 6.3](#), appears on the driver display during startup.

After startup, if a trailer is not attached to the tractor, a grey triangle appears on the driver display screen as shown in [Fig. 6.17](#). If a trailer is attached, a grey triangle with trailer appears.

If SGA monitoring experiences an error or is deactivated without a trailer attached, a grey triangle with a slash appears.

If SGA monitoring is deactivated with a trailer attached, a triangle with a trailer and a slash appears.

NOTE: When the transmission is shifted to reverse the SGA deactivated telltale is displayed in the instrument cluster until the transmission is shifted back to Neutral (N) or forward gears.

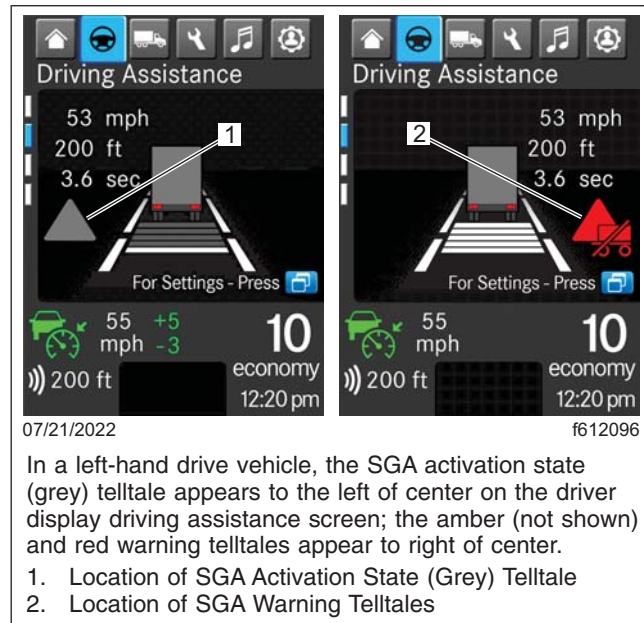

Fig. 6.17, SGA Telltale Locations, ICUC

The M2 Plus vehicle has an optional SGA OFF physical switch, used to support specific operations where SGA could have false positives. See [Fig. 6.18](#). The driver can turn the SGA function off at any time and it will remain off until the driver deactivates the switch, or until a complete key cycle turns the SGA feature on. When the SGA OFF switch

is used, the telltale for Side Guard Assist Error or Deactivation illuminates as shown in [Table 6.3](#).

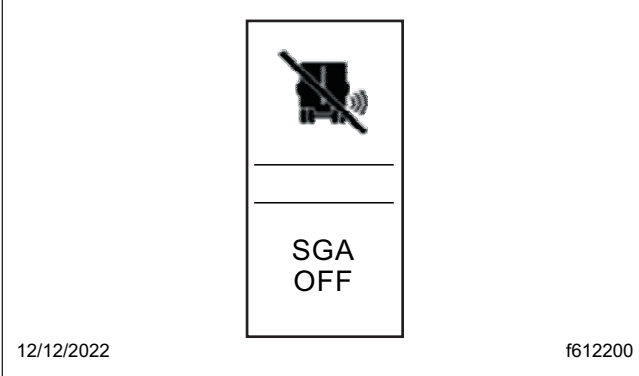

Fig. 6.18, SGA OFF Switch

Warnings for Moving Objects

If there is a moving object in the SGA monitoring range, shown in [Fig. 6.19](#), an amber SGA warning lamp in the A-pillar activates and the ICU displays the appropriate SGA caution telltale.

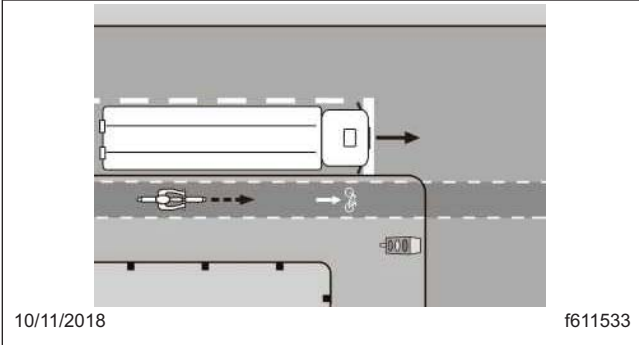

Fig. 6.19, A Moving Object in the SGA Monitoring Range

Warnings When Turning Right

SGA recognizes when the driver signals or steers to the right and there is a risk of collision. See [Fig. 6.20](#). In this situation, the red SGA warning lamp in the A-pillar flashes for a few seconds, a warning tone sounds, and the ICU displays the appropriate SGA warning telltale. After flashing, the red warning lamp stays on as long as there is a risk of a collision.

Warnings When Changing Lanes

If there is a moving object in the SGA monitoring range when a driver signals or steers to the right,

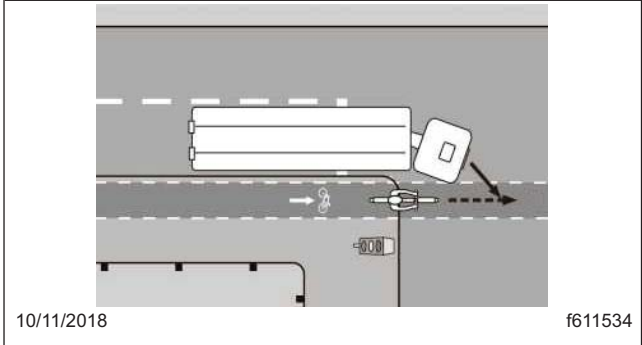

Fig. 6.20, A Moving Object in the SGA Monitoring Range When Turning Right

shown in [Fig. 6.21](#), an amber warning lamp activates in the A-pillar and the appropriate SGA caution telltale appears on the driver display screen.

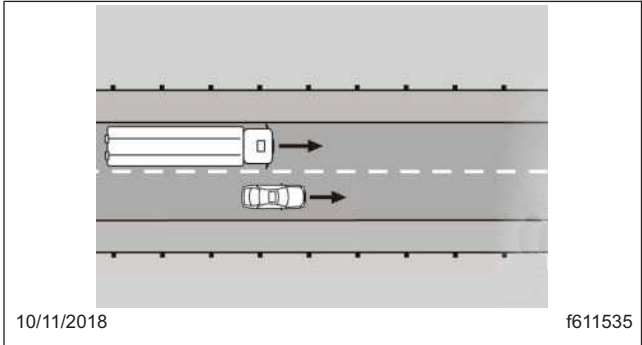

Fig. 6.21, A Moving Object in the SGA Monitoring Range When Changing Lanes

If there is a moving object in the SGA monitoring range when a driver signals or steers to the right, shown in [Fig. 6.22](#), the red warning lamp in the A-pillar flashes and a warning tone sounds and the appropriate SGA warning telltale appears on the driver display screen. The red warning lamp stops flashing after a few seconds but stays on as long as there is a risk of a collision.

Warnings When Turning Right for Stationary Obstacles

IMPORTANT: SGA is only an aid. It may fail to detect some objects and is not a substitute for attentive driving. Always ensure that there is sufficient distance to the side for vehicles, cyclists, pedestrians, and obstacles.

SGA warns the driver about stationary obstacles in the vehicle's range of movement up to a maximum speed of 22 mph (35 km/h).

Detroit Assurance 5.0

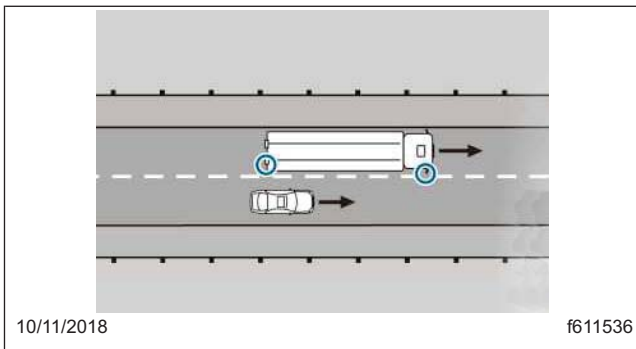

Fig. 6.22, A Moving Object in the Monitoring Range When Changing Lanes

If there is a risk of collision with a stationary obstacle when turning right, the red warning lamp in the A-pillar flashes and a warning tone sounds and the appropriate SGA warning telltale appears on the driver display screen. The red warning lamp stops flashing after a few seconds but stays on as long as there is a risk of a collision.

Detroit Assurance Traffic Sign Display

General Information

NOTE: Traffic sign display requires Intelligent Powertrain Management (IPM) to function.

If equipped, the Detroit Assurance Traffic Sign Display system may increase road safety by making the driver aware of posted traffic signs. Traffic sign display uses video data from the multipurpose camera in combination with GPS map data to recognize USA and Canadian traffic signs and display them on the ICUC 'Driver Assistance' screen. GPS information dictates the language and style of the sign display.

Safety Information

Traffic sign recognition and display is only intended as an aid for a conscientious and alert driver. The system may not operate as designed under the following conditions:

- There is low visibility caused by insufficient road illumination or because of snow, rain, fog, smoke, or heavy spray.
- There is glare or reflections from oncoming traffic, the sun, or a wet road surface.

- There are variable shade conditions on the road surface.
- The windshield is dirty, misted up, damaged, or covered in the vicinity of the camera.
- The traffic signs are partly or fully hidden by other vehicles, bushes, or trees.
- The distance from the vehicle in front is too small and it prevents the traffic signs from being detected in time.
- The traffic signs are designed in a non-standardized form, with additional text, or are LED panels.
- The traffic signs are damaged, bent, twisted, stained, or scratched.
- The traffic signs are posted on the far side of the road or very high above the road and out of view of the camera.
- The road is very wide, winding, or has sharp turns.
- GPS satellite reception is limited due to geographical location or development along the road.
- The onboard map data is outdated due to recent changes in local traffic regulations or new road layout.

The traffic sign recognition system not take the road and weather conditions into account, nor the current traffic situation. The driver is responsible for the distance to the vehicle in front, for vehicle speed, braking in good time, and remaining in the lane.

Traffic Sign Display Functionality

NOTE: Only three types of USA and Canadian traffic signs are currently detectable:

- speed limit signs (from speeds 5 to 140)
- passing signs
- exclusion signs

See **Fig. 6.23** for currently recognized USA signs and **Fig. 6.24** for Canadian signs.

When a traffic sign is recognized by the system, an image representing it appears in the instrument panel. See **Fig. 6.25**. The ICU displays up to two traffic signs at a time. If more than two signs are recognized by the system, the most safety critical signs are displayed.

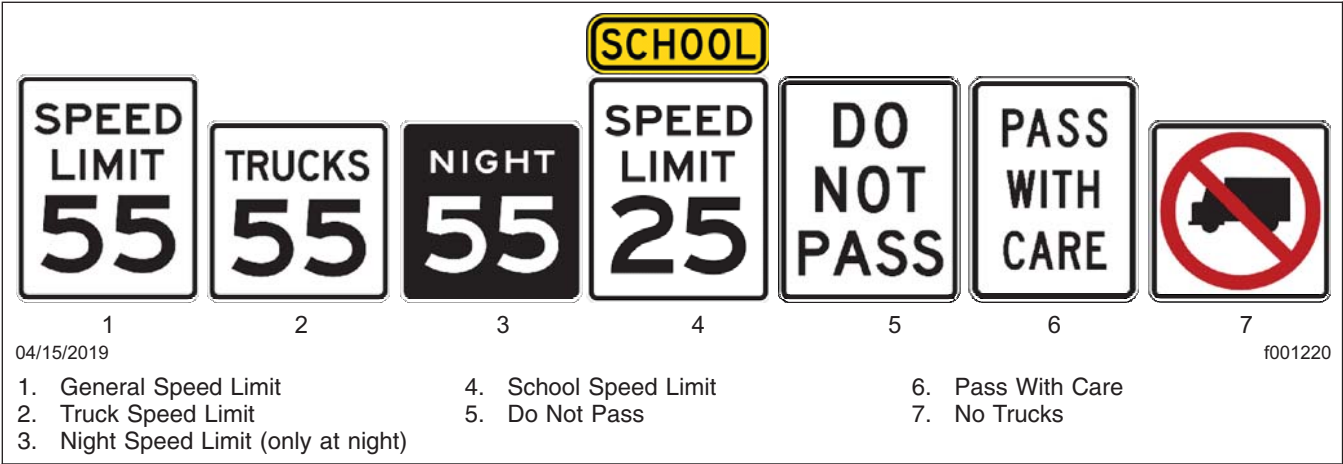

Fig. 6.23, Currently Recognizable Traffic Signs, USA



Fig. 6.24, Currently Recognizable Traffic Signs, Canada

Traffic Sign Display With Speed Limit Emphasis

Traffic sign display with speed limit emphasis displays a red glow around a displayed speed limit sign if the current vehicle speed exceeds, by a set threshold, the detected speed limit.

Traffic Sign Display With Warnings

Traffic sign display with warnings builds on speed limit emphasis. In addition to the red glow around speed limit signs, the following warnings are added:

- a pop-up notice window that tells the driver to slow down.
- a pop-up warning window that tells the driver to slow down, shown in [Fig. 6.26](#).
- an audible excessive speed warning

- a pop-up caution window accompanied by an audible warning that tells the driver not to pass

These warnings are triggered by the vehicle speed exceeding the detected speed limit by a set threshold for a minimum amount of time. The driver must acknowledge the visual warnings to dismiss them.

Active Speed Intervention

If the vehicle speed exceeds the detected speed limit by more than a set amount for a minimum duration, active speed intervention may, if equipped, temporarily limit engine torque, adjust the cruise control speed, or cancel cruise control to slow the vehicle.

Active speed intervention displays a pop-up warning window when any of these actions are taken. The pop-up warning window about limiting the engine's torque is shown in [Fig. 6.27](#). The driver must acknowledge these warnings to dismiss them.



Fig. 6.25, Traffic Sign Display, ICUC



Fig. 6.27, Example Active Speed Intervention Warning



Fig. 6.26, Traffic Sign Display Warning

Activating or Deactivating

Depending on the installed version of traffic sign display or active speed intervention, a virtual switch may be available under the 'Settings' menu on the ICU. This switch allows the system to be turned off or on.

When the ignition is turned on, traffic sign display restores the state of the system (either off or on) from the last ignition cycle.

Driver Assistance Features

Standard Cruise Control	7.1
Cruise Descent Control and Deceleration Modes	7.2
Hill Start Aid	7.3
Brake Hold	7.4
Intelligent Powertrain Management (IPM)	7.5
PasSmart	7.6
Electronic Stability Control (ESC)	7.6
SafetyDirect® by Bendix	7.7
Lytx SF500 DriveCam System	7.8

Driver Assistance Features

Standard Cruise Control

WARNING

Do not use the cruise control system when driving conditions do not permit maintaining a constant speed, such as in heavy traffic or on roads that are winding, icy, snow-covered, slippery, or roads with a loose driving surface. Failure to follow this precaution could cause a collision or loss of vehicle control, possibly resulting in personal injury or property damage.

NOTICE

When the cruise control is engaged, do not attempt to shift gears without using the clutch pedal. Failure to follow this precaution may result in a temporarily uncontrolled increase in engine speed. Transmission damage and gear stripping could result.

NOTE: If the vehicle is equipped with a Detroit DT12 automated transmission, setting the cruise control with the engine brake on activates cruise descent control mode. Moving the transmission shift lever to the top position resumes the set cruise speed. Moving the lever down to engage the engine brake after the cruise control has been set activates deceleration mode. See 'Cruise Descent Control and Deceleration Modes' in this chapter.

In the ICUC, standard cruise control is operated by three switches mounted in the right-hand switch pod of the steering wheel. See [Fig. 7.1](#).

- **Cruise Decelerate/SET Button**—Press to set the cruise speed while the vehicle is traveling at the desired speed. Press and hold to decrease the set cruise speed by 5 mph increments (Detroit Diesel engines only). Single press decreases cruise speed by 1 mph. When cruise control has been set, the driver display static menu in the ICUC shows relevant cruise control icons and the set speed. See [Fig. 7.2](#). The speed memory is retained until the ignition is turned off.
- **CNCL Button**—Press to pause the cruise control, while retaining the speed setting in memory. The cruise control can also be disengaged, while retaining the speed memory, by depressing the brake or clutch pedals.

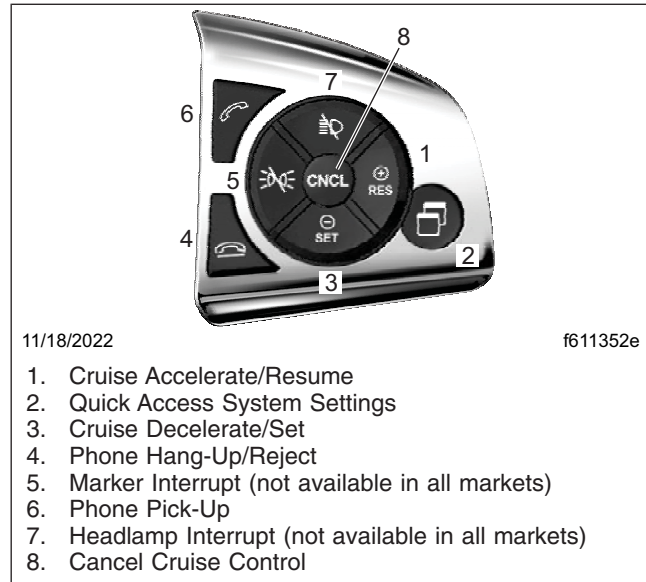

Fig. 7.1, Steering-Wheel-Mounted Right-Hand Switch Pod, ICUC

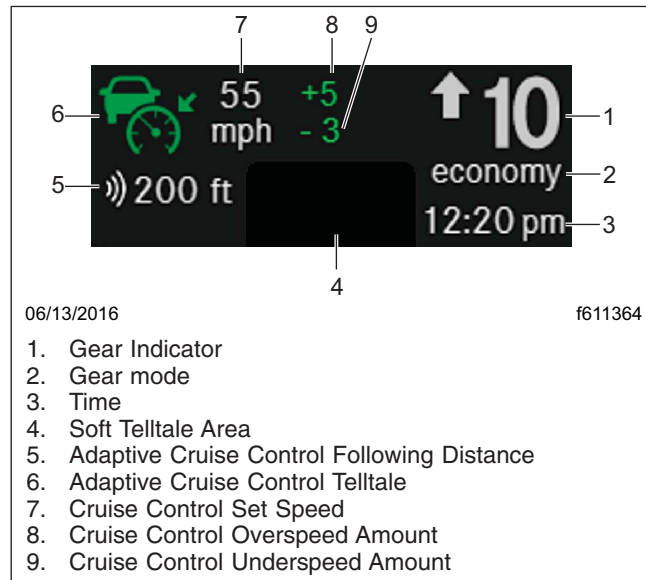

Fig. 7.2, Static Menu, ICUC

- **Cruise Accelerate/RES Button**—Press to resume the set speed. Press and hold to increase the set cruise speed by 5 mph increments (Detroit Diesel engines only). Single press increases cruise speed by 1 mph. If no previous set speed is stored, pressing the button sets the cruise speed.
1. To cruise at a particular speed:

- 1.1 Depress the accelerator pedal until the speedometer reaches the desired speed.
- 1.2 Press the cruise decelerate/SET button to set the desired speed.

NOTE: The set speed memory is lost whenever the ignition is turned off.

2. To disengage the cruise control, do one of the following:
 - Press the CNCL button in the center of the right-hand steering-wheel-mounted switch pod. A single press disengages the cruise control, but retains the set speed.
On vehicle's equipped with a Detroit Diesel engine, press and hold the CNCL button to clear the set speed.
 - Depress the brake pedal.
 - If equipped with a manual transmission, press the clutch pedal.
3. To resume a preselected cruise speed, press the cruise accelerate/RES button. Cruise control returns to the last set speed.

NOTE: If vehicle speed drops below the minimum cruise control speed, cruise control disengages. To resume to the preselected cruise speed, increase the vehicle speed to above the minimum cruise control speed and press the cruise accelerate/RES button.

4. To increase cruise speed, press the cruise accelerate/RES button until the desired set speed is displayed.
5. To decrease cruise speed, press the cruise decelerate/SET button until the desired set speed is displayed.

The cruise speed hysteresis (maximum speed above and below the set speed) can be set in the ICU settings menu. The leading vehicle following distance can be set using the quick access button.

Cruise Descent Control and Deceleration Modes

NOTE: As a feature of cruise control, descent control mode works with all transmission options; however, cruise control can only request a specific gear if the vehicle is equipped with a DT12. Descent control mode with

transmissions other than D12 is therefore limited.

On vehicles equipped with a Detroit DT12 automated transmission, the functions of the engine brake controls change, depending on which specialty braking mode is being utilized. Two distinct modes can be activated:

- **Descent control mode:** engine braking attempts to maintain a set speed; accelerator pedal is not automatically applied. Setting the cruise control speed with the engine brake on activates cruise descent control mode. Moving the transmission shift lever to the top position resumes the set cruise speed.
- **Deceleration mode:** engine braking activates to reduce vehicle speed (with no lower limit) at a constant rate. Moving the transmission shift lever down to engage the engine brake after the cruise control has been set activates deceleration mode.

Descent Control Mode

NOTE: Before engaging descent control, determine an appropriate speed for the vehicle's load and grade of the road.

Descent control mode attempts to keep the vehicle speed at the set speed using all available engine brake stages when descending a grade.

To activate descent control mode:

1. Exit cruise control.
2. Remove your foot from the accelerator pedal.
3. Set the engine brake to any of the three 'on' positions as shown in [Fig. 7.3](#).
4. Use the set or resume buttons to set the vehicle speed.

The descent control mode active telltale illuminates on the driver display when descent control mode is active. See [Fig. 7.4](#).

In descent control mode, all three levels of engine braking are employed to keep the speed below the set speed regardless of the level selected by the right-hand stalk switch.

In the case of very steep road grades, the engine brake may not be able to maintain the vehicle speed. The driver may apply the service brakes without dropping out of descent mode to slow the vehicle. If the vehicle is slowed below the set speed, this lower

Driver Assistance Features

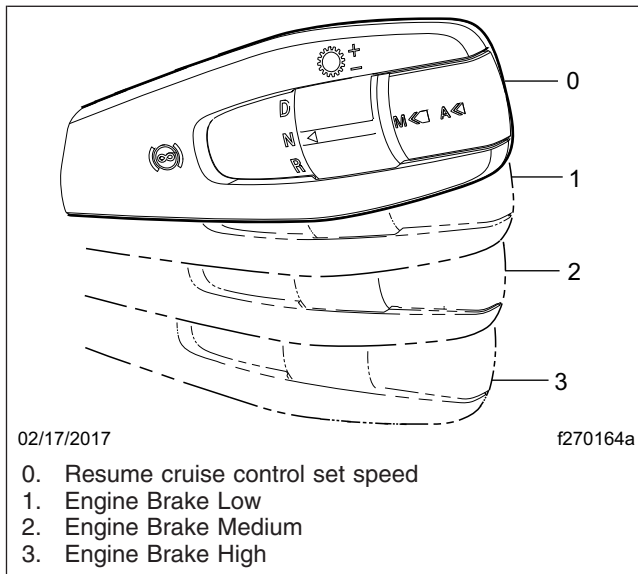

Fig. 7.3, Descent Control Mode Engine Brake Positions

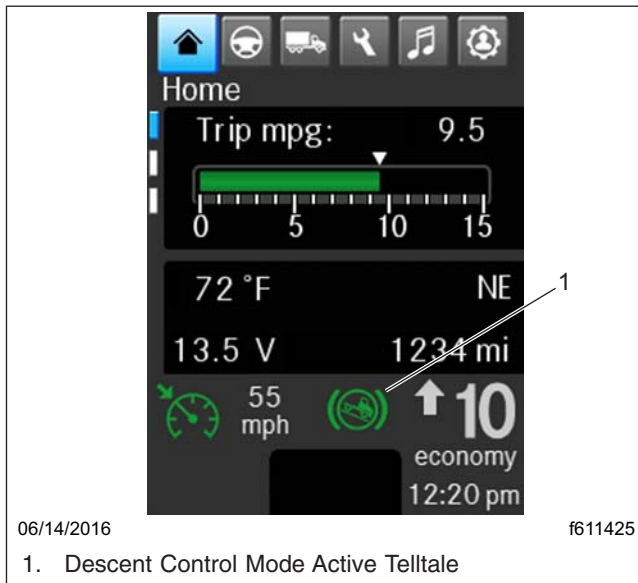

Fig. 7.4, Descent Control Mode Telltale, ICUC

speed becomes the set speed after the driver releases the service brakes. In this instance, a pop-up window in the ICU notifies the driver that a new set speed was captured, as shown in **Fig. 7.5**.

Descent control mode does not keep the speed above the lower limit of the set speed, so it is possible to eventually coast to a stop, unless the stalk lever is moved to 'off' (position 0), or the accelerator pedal is applied.

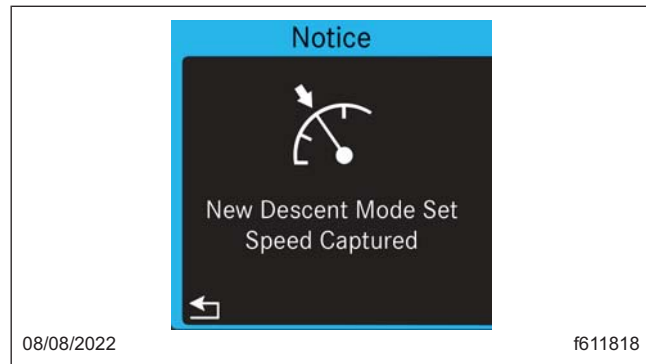

Fig. 7.5, Descent Mode Speed Set Notification, ICUC

After accelerator pedal application, descent control mode is resumed.

Moving the lever to the 0 position deactivates descent control mode and resumes cruise control, using the descent control set speed as the cruise control set speed.

Deceleration Mode

Deceleration mode reduces the vehicle speed at a constant rate.

While in cruise control, activate deceleration mode turning on the engine brake using the right-hand stalk switch as shown in **Fig. 7.3**. The vehicle decelerates at a constant rate until the vehicle comes to a stop, unless the accelerator pedal is applied to override the deceleration, or the right-hand stalk switch is moved to 'off' position.

Moving the lever to 'off' resumes the previously set cruise control speed.

Hill Start Aid

The hill start aid (HSA) feature prevents the vehicle from rolling on a slope steeper than three percent to allow for a controlled launch.

HSA prevents a stationary vehicle in forward gear from rolling downhill prior to continuing to drive up the hill; HSA also prevents a stationary vehicle in reverse gear from rolling downhill prior to continuing to back up the hill.

HSA delays the release of service brakes until enough torque is available to begin moving the vehicle, up to a maximum of three seconds. If sufficient driveline torque is not detected after three seconds, the system audibly alerts the driver and releases the brakes.

HSA is on by default. It can be turned off by pressing the HSA OFF dash switch shown in [Fig. 7.6](#).

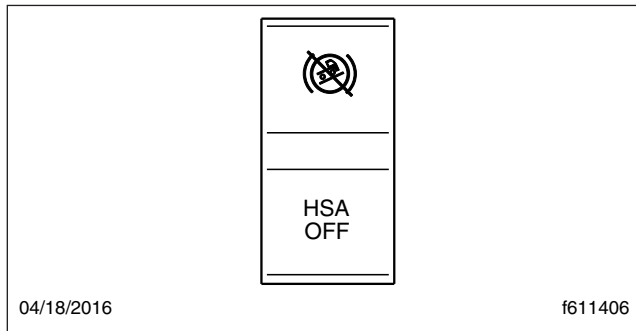

Fig. 7.6, Hill Start Aid Off Dash Switch

When hill start aid is inactive, the HSA OFF telltale, shown in [Fig. 7.7](#), flashes on the driver display screen.

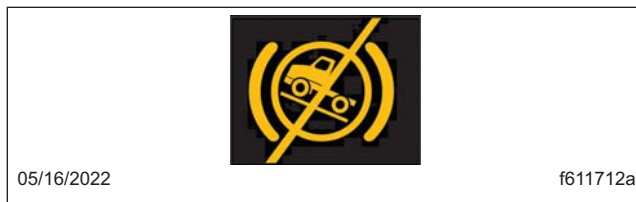

Fig. 7.7, Hill Start Aid Disengaged Telltale

To turn hill start aid on again, press the HSA OFF switch or cycle the vehicle keyswitch.

If the hill start aid disengaged telltale appears as a solid image on the driver display screen, there is a fault in the system.

Brake Hold

The brake hold function eases the strain of driving in stop-and-go traffic by allowing the driver to "hold" the brake without constantly applying pressure to the brake pedal. The brake hold function is an extension of hill start aid (HSA).

To activate the brake hold function, bring the vehicle to a complete stop, then press the brake pedal further toward the floor. The HOLD telltale, shown in [Fig. 7.8](#), illuminates on the driver display to indicate the function is active and the vehicle's brake lights come on. The driver can then take their foot off the brake pedal without releasing the service brakes.

If the brake pedal is pressed down farther, air is added to the chamber, continuing the brake hold.



Fig. 7.8, Brake Hold Active Telltale

To release the brake hold, press the accelerator pedal, engage the park brake, or rapidly apply and release the brake pedal.

The hold function is deactivated when the HSA OFF switch is pressed to disable HSA.

The hold function cannot be engaged if any of the following are true:

- the anti-lock braking system was active in bringing the vehicle to a stop,
- the anti-lock braking system is in a fault state, or
- the vehicle is in reverse gear.

If the hold function is active for four minutes, the window shown in [Fig. 7.9](#) appears on the ICU warning the driver to engage the park brake. An audible alarm activates at the same time and repeats every minute until the park brake is set.

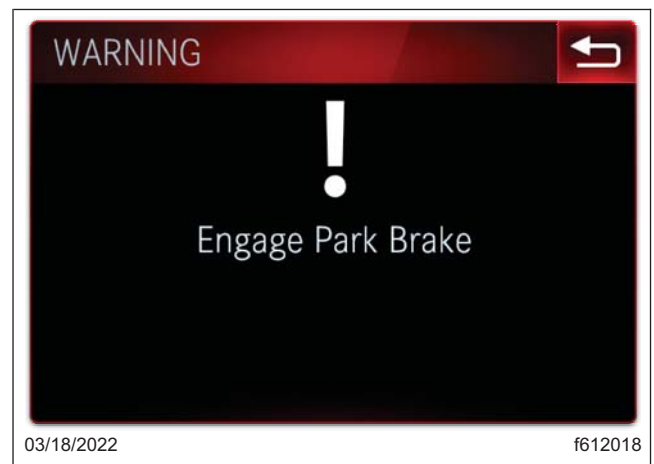

Fig. 7.9, Engage Park Brake Message

The same warnings are triggered if the hold function is active and:

- the ignition is turned off without the park brake being set, or
- the brakes are not strong enough to hold the vehicle in place and it starts rolling.

Driver Assistance Features

If a door is opened without the park brake being set when the hold function is active, the horn sounds and a visual warning activates on the driver display. If the seat occupancy sensor registers an empty seat under the same conditions, the same warnings are triggered. Warnings cease when the condition that triggered the warning is corrected.

Intelligent Powertrain Management (IPM)

NOTE: IPM is standard with a DT12 transmission; IPM is not available with an Eaton or Allison transmission.

IPM is an optional fuel savings application that functions as a predictive cruise control. Using 3D digital map technology and GPS, IPM evaluates the upcoming road grade about a mile in advance to determine the best use case for most fuel-efficient vehicle speed and gear selection.

The IPM active telltale illuminates on the driver display when an IPM mode is activate. See [Fig. 7.10](#).



Fig. 7.10, IPM Active Telltale, ICUC

The 3D digital map database contains profile information for over 200,000 highway miles (322,000 km) in the 48 contiguous United States, the Trans-Canada Highway, and most major Canadian highways.

Using these maps, IPM varies the cruise speed, depending on the approaching road grade.

For a vehicle equipped with the Economy Package, the default variance is +5/-4 mph (+8/-6 km/h). If the engine brake is enabled, IPM may automatically engage the engine brake at speeds higher than the cruise set speed.

Key predictive features of IPM are:

- Steep Mountain Mode — applies if the vehicle does not maintain cruise set speed while climbing. To balance travel time while saving fuel, the vehicle predictively accelerate before starting the climb, then may slow down as it approaches the crest of the hill. In this scenario the speed is allowed to fall below the cruise control underspeed.
- Crest Coasting — reduces speed before cresting a hill
- Dip Coasting — increases speed before a dip
- Predictive Shifting — selects a gear shifting strategy for upcoming terrain
- Load Balancing — maintains most efficient power for near zero road grades; small fluctuation in road speed may be seen from cruise set speed by ± 1 or 2 mph
- Predictive Adaptive Cruise Control — if equipped with adaptive cruise control (ACC), allows IPM to increase following distance

IMPORTANT: IPM behavior is different from that of conventional cruise control. The system incorporates features to improve the overall driver experience. Some key points to remember are:

- IPM is active only when cruise control is engaged.
- IPM only controls speed within the upper and lower bounds of the cruise set speed. The upper and lower set limits may be exceeded up to 2 mph (3 km/h) for a limited time during dip coasts, as IPM predicts the terrain demands for the most fuel-efficient performance. The driver is responsible for setting a speed appropriate for the conditions and grade. If equipped, IPM upper and lower bounds can be adjusted by selecting the quick access button on the steering wheel.
- IPM can engage eCoast sooner, later, or not at all compared to conventional cruise control.

- IPM may automatically engage the engine brake at a higher speed than the cruise set speed.
- If IPM becomes unavailable, conventional cruise control can still function.

WARNING

Apply the brakes and downshift as necessary when driving on downhill grades. IPM does not adequately control vehicle speed on steep downhill grades. Failure to use normal braking techniques when IPM is active could result in personal injury and vehicle damage.

IMPORTANT: IPM adjusts the vehicle set speed to achieve maximum fuel economy, but it does not account for traffic flows or surrounding vehicles.

For best fuel-savings, use cruise control whenever possible. Driver interaction with IPM is the same as standard adaptive cruise control. In the event of a problem with IPM, or when driving on a road with no profile information available, the system reverts to standard adaptive cruise control.

Using the accelerator pedal cancels the current IPM session. Disengaging the cruise control also deactivates IPM.

PasSmart

A standard feature on fleet vehicles, PasSmart enables a vehicle to exceed a set speed limit by a limited amount to allow for passing vehicles on the highway. For example, a PasSmart vehicle may be programmed to enable the vehicle to travel 5mph over a set speed limit for 30 minutes every 24 hours. This speed limiting increases overall fuel economy.

If equipped, the PasSmart function is initiated by double-pumping the accelerator pedal within a two second period. When initiated, the PasSmart window as shown in [Fig. 7.11](#) appears. The PasSmart timer shown in this window starts when the road speed limit is exceeded by 1.89 mph (3 km/h).

PasSmart does not disengage cruise control. After engagement, PasSmart deactivates when the speed limit of the vehicle drops below the cruise control standard set speed limit at which point cruise control resumes.

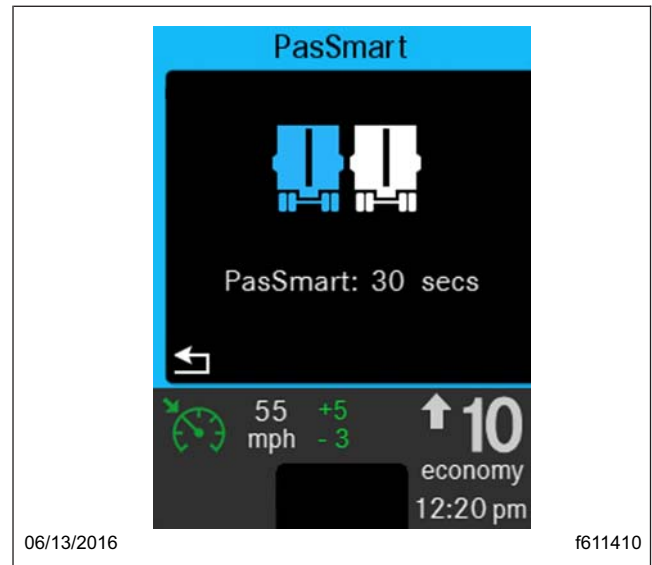

Fig. 7.11, PasSmart Active, ICUC

Thirty seconds before a daily PasSmart limit is reached, the PasSmart active window, if closed, opens to notify the driver of the time remaining.

Electronic Stability Control (ESC)

WARNING

ESC is intended only as an aid for a conscientious and alert driver. Carefully read the information in this manual to understand this system and its limitations. ESC is not a substitute for safe driving procedures. Failure to drive safely, and use the system properly, could result in personal injury and/or death and property damage.

CAUTION

Changing or modifying the location of the ESC sensor or reconfiguring the vehicle, such as by changing the wheelbase or adding axles, can change the performance of the enhanced stability control system and may result in product or property damage and personal injury.

Electronic stability control (ESC) works by constantly comparing the driver's intention with the vehicle's actual behavior. The system does this by monitoring wheel speed, steering angle, yaw rate, lateral acceleration, throttle position, and brake application.

Driver Assistance Features

A central microcomputer analyzes the collected data and triggers a response to keep the vehicle on course when an unstable condition is detected.

When the system detects that the vehicle is at risk of over-steering or under-steering, it applies individual tractor wheel end brakes and trailer brakes and/or cuts power to reduce the likelihood of a drift-out or jackknife.

If the acceleration sensor detects the vehicle is at risk of rolling over, the roll stability control system within the ESC automatically reduces power and applies the brakes.

Yaw control is not active below approximately 6 mph (10 km/h). Roll stability control is not active below approximately 12 mph (20 km/h). At higher speeds, ESC operates automatically; the driver does not monitor or activate the system.

The driver has full control over the vehicle until the system detects a potential risk and intervenes accordingly.

The ESC telltale, as shown in [Fig. 7.12](#), appears on the driver display when ESC intervenes and when ESC is unavailable due to a fault. The ESC telltale flashes when an ESC event is actively occurring and is solidly illuminated when ESC is unavailable due to a fault.



Fig. 7.12, Electronic Stability Control (ESC) Telltale

It is normal for the ESC telltale to illuminate shortly after a curve, lane change, or other driving maneuver that results in ESC detecting a rollover-risk.

SafetyDirect® by Bendix



SafetyDirect by Bendix is solely intended as a support for a conscientious professional driver.

IMPORTANT: In order for the forward facing camera to operate properly, the windshield area

in front of the camera must be clean, unobstructed, and not be damaged in any way.

SafetyDirect by Bendix is a fleet management system that automatically records ten to twenty seconds of video during a safety event and delivers it and other vehicle safety data wirelessly and in real time to the Bendix SafetyDirect portal.

Bendix Forward Facing Camera

If equipped, the SafetyDirect system uses the telematics systems of the vehicle and a Bendix 5G forward facing video camera, shown in [Fig. 7.13](#). The Bendix camera records in color and can capture high-quality video in low light conditions.

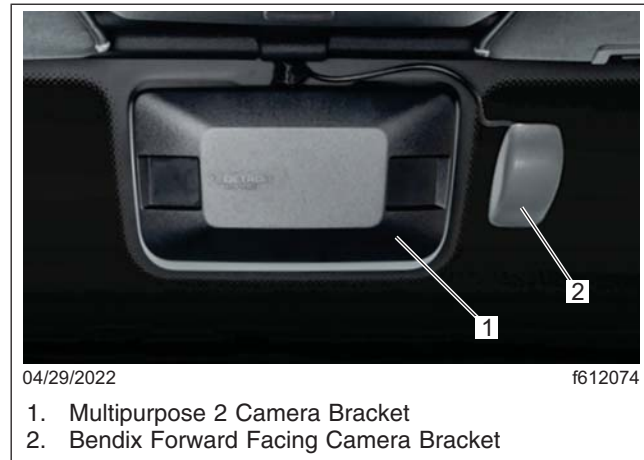

Fig. 7.13, Multipurpose Camera 2 and Bendix Camera Brackets

Driver Facing Camera

If equipped with a driver facing camera, the SafetyDirect system also records ten to twenty seconds of driver behavior during an event.

The Bendix SafetyDirect Portal

If the vehicle is equipped with the SafetyDirect system, data is sent from the vehicle's safety systems to the portal. The portal presents each driver's behavior in a 'miles between events' format with the following events recognized:

- lane departure warning
- excessive lane departure warning
- lane change without turn signal
- loss of video tracking

- lane departure warning system disabled
- distance/tailgate alert given
- forward collision warning
- collision mitigation braking
- automatic traction control (ATC) activation
- antilock braking system activation
- stability system activation
- excessive braking
- excessive speed on curves
- average following distance
- adaptive cruise control usage

Lytx SF500 DriveCam System Driver Facing Camera

WARNING

The Lytx DriveCam event recorder is a driver aid only. It is not a substitute for a safe, conscientious driver. It cannot compensate for a driver that is distracted, inattentive, or impaired by fatigue, drugs, or alcohol. Whether or not the Lytx DriveCam event recorder is in use, it is always the responsibility of the driver to take appropriate corrective action. Never wait for the Lytx DriveCam event recorder to provide a warning or audible alert before taking measures to avoid an accident. Failure to do so can result in severe property damage, serious personal injury or death.

The Lytx SF500 DriveCam System constantly monitors driving behaviors. When risky driving behavior is detected it begins a recording, indicated by a red light in the camera. An audible alert sounds to alert the driver. The alerts can not be muted and continue to occur until the driver corrects the behavior.

Risky driving behaviors that may be monitored include:

- Driver Smoking
- Food or Drink
- Handheld Device
- Inattentive or Distracted Driver
- No Seat Belt

- Speed (company policy)
- Speed (posted speed)
- Following Distance
- Lane Departure

Vehicles equipped with a Lytx SF500 driver facing camera have a switch on the dash as shown in 7.14. Press the VIDEO REC switch to manually initiate a ten-second recording. An amber lamp in the switch illuminates while the recording is in process.

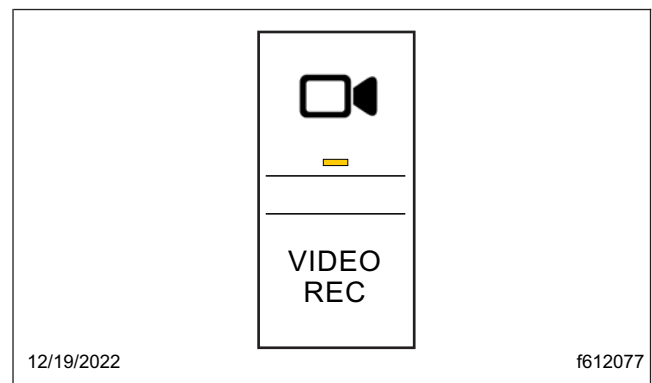

Fig. 7.14, Lytx Video Record Switch

The Lytx SF500 DriveCam System automatically turns on a privacy mode when the parking brake is set. When the vehicle is on, it is indicated by a solid blue LED light on the Lytx camera. This mode cannot be initiated by the driver.

Videos can be viewed on the Lytx account system which requires approval to access.

For more information, access the Lytx SF500 DriveCam System User's Manual by scanning the Lytx QR code shown in Fig. 7.15.



Fig. 7.15, Lytx QR Code Link to Manual

Electrical System

System Overview	8.1
Power Distribution	8.2
Cab Load Disconnect Switch	8.4
Emergency Power Mode	8.5
Powernet Management	8.5

Electrical System

System Overview

Power is supplied by the vehicle power distribution modules (PDMs) to electronic control units (ECUs). The ECUs coordinate power to outputs such as lighting, displays, gauges, and indicators and control power distribution by monitoring inputs such as sensors and switches. The ECUs also continuously monitor the status of all input devices and transmit messages over multiple control area networks (CANs), reducing the number of sensors required for operation.

The Instrumentation Control Unit (ICU) and Fault Codes

The majority of electrical and electronic issues on the vehicle have an associated fault code, which will be displayed on the ICU. If the ICU receives active fault codes during the ICU self-check, it displays them one after the other until the parking brake is released or the ignition is turned off. Once the parking brake is completely released, the ICU displays alerts until acknowledged. See [Fig. 8.1](#). If there are no active faults, the ICU displays the home screen after the self-check completes.

NOTE: Some non-critical faults may be suppressed and will not appear during an instrumentation control unit (ICU) self-check.



Fig. 8.1, ICUC Active Faults Alert Screen

When there is an active vehicle fault code, a popup appears on the ICU message screen.

To access fault codes in the ICU:

1. Use the buttons on the left-hand steering wheel to navigate to the wrench icon and press OK. See [8.2](#)



Fig. 8.2, Electronic Control Unit (ECU) List in the ICUC

2. ECUs with active faults have an exclamation point next to them. Use the down arrow to select the affected ECU from the list, then press OK.
Refer to the ECU acronyms list for the full names of acronyms on the ICU screen. See [Table 8.1](#).
3. Locate the code to troubleshoot from the list of active fault codes, then press OK to access the information screen. See [Fig. 8.3](#).
4. Press OK again to access additional information. See [Fig. 8.4](#).

To troubleshoot and resolve fault codes, take the vehicle to an authorized Freightliner service center for diagnostics.

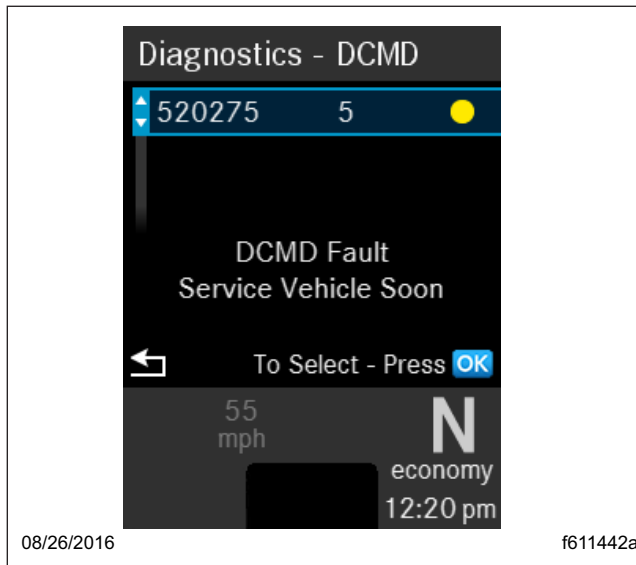

Fig. 8.3, Information Screen for an Active Fault Code

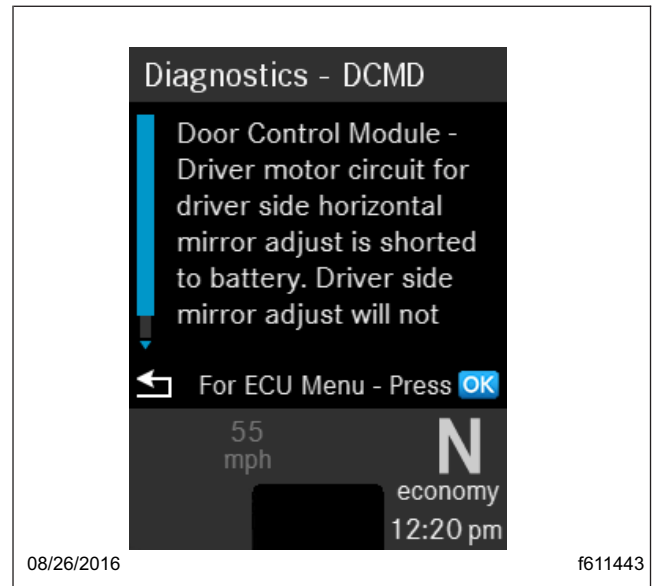

Fig. 8.4, Additional Information for the Fault

ICU Electronic Control Unit Acronyms			
ABS	Antilock Brake System	ICU	Instrumentation Control Unit
ACM	Aftertreatment Control Module	MCM	Motor Control Module
CGW	Central Gateway	RDF	Radar Front End
CPC	Common Powertrain Controller	SAS	Steering Angle Sensor
DCMD	Door Control Module, Driver	sSAM	Single Signal Detect and Actuation Module
DCMP	Door Control Module, Passenger	TCM	Transmission Control Module
HVCF	Heating/Ventilation/AC Front (HVAC)	TPMS	Tire Pressure Monitoring System
HVCP	Heating/Ventilation/AC, Auxiliary (HVAC)	VRDU	Video Radar Decision Unit

Table 8.1, ICU Electronic Control Unit Acronyms

Power Distribution

The power distribution system provides battery power to the electrical and electronic systems.

The following components make up the vehicle power distribution system:

- Battery Cable Access (BCA)
- Power Distribution Modules (PDMe and PDMi)
- Cab Load Disconnect Switch

Vehicle power is supplied by the batteries to the battery cable access (BCA) box. The BCA front wall pass-through is the primary interface through which battery power gets transferred from outside the cab to the inside. It is located on the passenger side of the engine compartment front wall. This provides a

disconnect point for harness service, testing, and replacement. See Fig. 8.5.

The power supplied by the batteries goes to the vehicle power distribution modules and the single signal detect and actuation (sSAM) module.

The PDMs are fuse power distribution boxes. They provide power and circuit protection for powertrain needs, cab functions, and various stand alone modules. They also supply power to the emergency power supply circuits in the event of a module failure. The PDMe is located in the engine compartment on the frontwall. See Fig. 8.6. The PDMi is located in the vehicle electronics bay, behind the passenger-side dash panel. See Fig. 8.7.

Depending on a vehicle's specifications, the fuses and relays installed and their locations can vary.

Electrical System

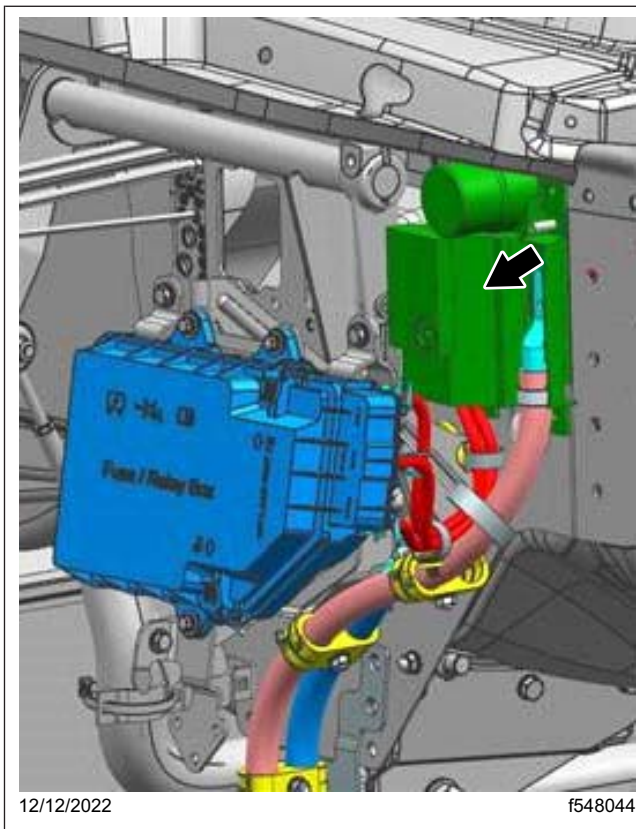

Fig. 8.5, BCA



Fig. 8.7, Power Distribution Module (PDMi) Behind Right-Side Dash

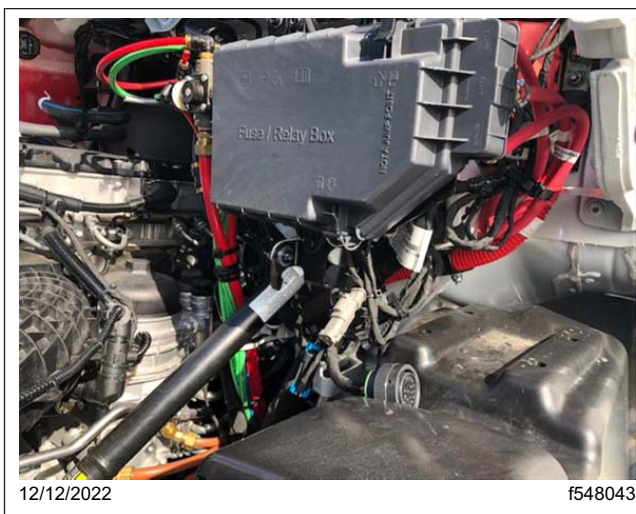

Fig. 8.6, Power Distribution Module (PDMe) in Engine Compartment

Each PDM inside cover has a fuse map with an image of the fuse layout for that vehicle.

Cab Electrical and Electronic Components

Advanced Signal Detect and Actuation Module (ASAM)

The advanced signal detect and actuation module (ASAM) is the primary module in the electrical system, combining chassis power distribution, cab power distribution, and modular switch functions into a single ECU. The ASAM does **not** contain fuses or relays.

The ASAM reads input information from sensors, switches, and databus messages, and drives output and controller area network (CAN) messages. The ASAM is located behind the right side dash panel. See [Fig. 8.8](#).

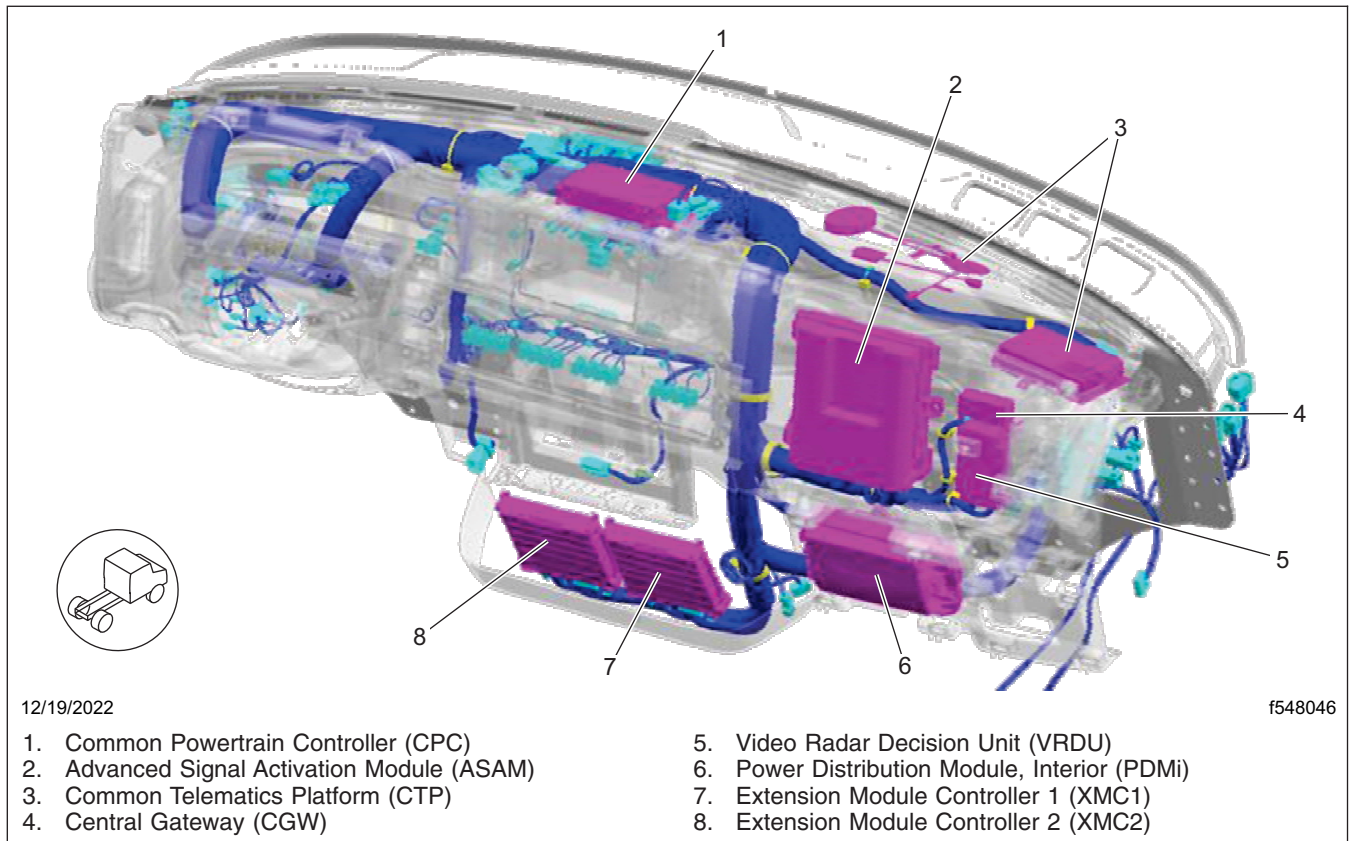

Fig. 8.8, Component Locations Behind the Dash

Cab Load Disconnect Switch

WARNING

Turning the cab load disconnect switch (CLDS) to the OFF position does not disconnect power to all electrical components (e.g. the starter and sSAM). To work on the vehicle safely, the negative leads must be disconnected from the battery.

The cab load disconnect switch can be used to disconnect the circuits between the battery and the battery cable access box (BCA), minimizing the power draw on the battery when the vehicle is parked for an extended period of time.

The CLDS may be mounted in a variety of locations, including:

- inside the cab on the outboard side of the driver's seat;
- behind the cab on the driver's side;

- at the battery box;
- outside of the cab.

The ignition must be turned OFF before turning the cab load disconnect switch ON or OFF.

The CLDS is set to ON for normal daily use. When the CLDS is set to ON, a steady red LED indicator at the base of the switch selector illuminates. See [Fig. 8.9](#).

A flashing red LED indicates an error with the CLDS. Take the vehicle to an authorized Freightliner service center for diagnostics.

The CLDS should be set to OFF if the vehicle will be parked for more than two days. However, even with the CLDS OFF, the vehicle still draws a small amount of battery power. If parking the vehicle for more than five days, disconnect the batteries.

IMPORTANT: If the vehicle is driven while the CLDS is set to the OFF position, the vehicle will run on the emergency power feed but the

Electrical System

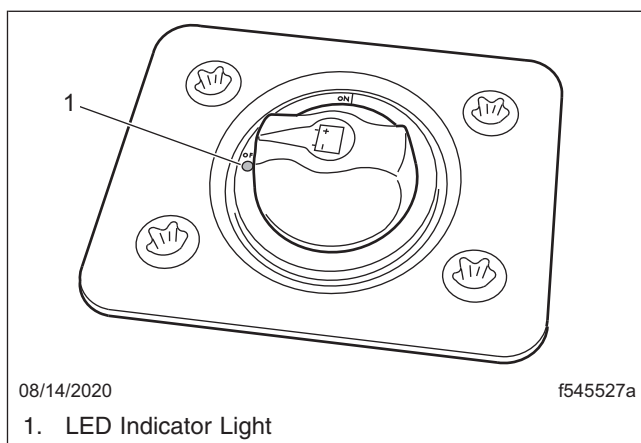

Fig. 8.9, Cab Load Disconnect Switch

batteries will not be charging. The **Emergency Power Mode** will activate.

Emergency Power Mode



WARNING

If emergency power mode activates, do not shut down the engine until the vehicle is out of traffic and in a safe place. The engine will not be able to be restarted until the cause of the loss of power is corrected.

The emergency power circuit allows a vehicle to be moved out of traffic and off the road in the event of a loss of power.

The emergency power circuit is live even when the cab load disconnect switch (CLDS) is turned off.

The following is a list of behaviors that could occur when in emergency power mode:

- Inoperative switches and lamps.
- Unresponsive or frozen gauges.
- Display of warning lamps that indicate low voltage and/or ECU faults.
- Lamps either constantly on or flashing.
- Windshield wipers on low speed.

The cause of the loss of power dictates the specific behaviors that appear. If emergency power mode is activated due to a microprocessor failure in the sSAM ECU, the gauges become unresponsive; this includes dash panel lamps and turn signal indicators.

NOTE: Possible variations in lamp illumination are noted in parentheses.

In emergency power mode with the ignition in the ON position the following lamps stay on constantly:

- dash panel lamps including turn-signal indicators (except in case of microprocessor failure in the sSAM ECU.)
- headlamp, low beams (left, right, or both sides)
- headlamp, accent lamps, left and right (in the case of a BCA fault)
- rear stop lamp (left, or both sides)

In emergency power mode with the ignition in the ON position the following lamps flash:

- headlamp turn signals, both sides
- trailer tail lamps, both sides
- outboard clearance lamps, both sides
- tractor tail lamps (right, left, or both sides)
- side marker lamps, forward (right, left, or both sides)
- identification lamps (all or none)

Turning the ignition switch to OFF when in emergency power mode shuts down the exterior lighting, windshield wipers, and the engine. The engine will not start if the ignition switch is turned back to the ON position.

Powernet Management

The powernet management feature protects the batteries from excessive discharge by disconnecting certain loads—features that draw power—from the battery power supply. This allows the batteries to maintain enough of a charge to restart the vehicle.

Features that draw power are prioritized into different categories:

1. House loads: This includes the majority of dash and sleeper power outlets, sleeper reading and spot lamps, and sleeper auxiliary fans.
2. Basic loads: This includes power for fleet management systems and third party telematics as well as critical dash and sleeper power outlets.

By making noncritical features that draw power temporarily unavailable, powernet management allows the driver to continue using critical features.

Progressive low voltage disconnect (PLVD) is used to implement the powernet management feature.

PLVD calculates disconnecting loads based on battery voltage, ignition switch status, and engine rpm. When battery voltage drops below a predetermined value, house loads are turned off. One minute before house loads are turned off, a pop-up message will display in the ICU and an audible alarm will sound.

The front reading lamp, spot lamp, and sleeper lamps—designated as house loads—can be turned back on after being shutdown by PLVD by pressing on the light or light switch.

No alarm sounds before basic loads are turned off.

A time delay is implemented for the shutdown and reactivation of loads to avoid unnecessary cycling when battery voltage is close to shutdown thresholds.

Loads disconnected by the PLVD will reconnect when all of the following conditions are met:

- ignition ON;
- engine at 450 rpm or above;
- batteries reach and maintain 12.7 volts for one minute.

9

Engine Starting, Operation, and Shutdown

Engine Starting	9.1
Engine Operation	9.2
Engine Shutdown	9.4
Engine Protection—Warning and Shutdown	9.4

Engine Starting, Operation, and Shutdown

Engine Starting

This engine chapter is to serve as a guide for best practices only. Each engine model may have operating characteristics that are unique to that particular engine, and is documented in the engine manufacturer's literature. Always refer to specific instructions and recommendations from the engine manufacturer.

NOTE: Before starting the engine, read [Chapter 3, Instruments](#), and [Chapter 4, Driver Controls](#). Read the engine manufacturer's operating instructions before starting the engine.

WARNING

Never pour fuel or other flammable liquid into the air inlet opening in the air intake in an attempt to start the vehicle. This could result in a flash fire causing serious personal injury or property damage.

IMPORTANT: Freightliner vehicles are equipped with starter interlocks to enhance reliability and safety. Anti-grinding, starter pinion, and thermal protection logic limit the amount of time and conditions for starter engagement. Cranking may be limited from 5 to 15 seconds, with a 30-second cool-down period, as determined by the protection logic. If the engine is turning, the starter will not engage. Depending on the transmission option, the starter will not engage if the clutch is not fully depressed, or if the transmission is not in neutral.

IMPORTANT: The starter **can not** be used for priming the fuel system. If the fuel/water separator filter is replaced, and the fuel system needs to be primed, see the engine manufacturer's operating instructions.

1. Before engine start-up, complete the pre- and post-trip inspections and maintenance procedures in [Chapter 22](#).
2. Set the parking brake.
3. Place the transmission in neutral. On vehicles with manual transmissions, fully depress the clutch pedal.

NOTE: Depending on local jurisdictional emissions regulations, vehicles and/or engines that are domiciled outside of the U.S. and

Canada may not be equipped with the STARTER BLOCKED function.

4. Turn the ignition switch to the ON position and allow the self-check to complete. See [Fig. 9.1](#).

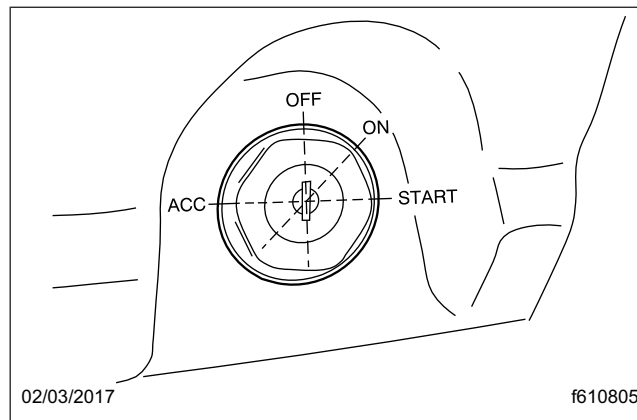

Fig. 9.1, Ignition Switch

NOTE: The driver display screen may present a STARTER BLOCKED message if the gauge sweep is not completed, the transmission is in gear, or the starter has overheated.

5. Once the gauge sweep has completed, turn the ignition key to the START position. Release the key the moment the engine starts.

If the vehicle is equipped with an engine start switch as shown in [Fig. 9.2](#), hold the switch down while turning the ignition key to the START position. Release the switch and the key the moment the engine starts.

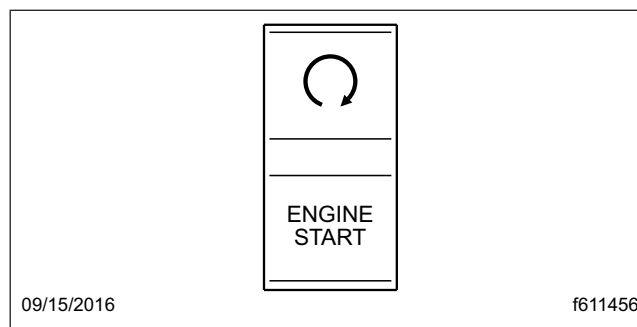

Fig. 9.2, Engine Start Switch

NOTICE

Do not rev the engine if the oil pressure gauge indicates no oil pressure. Shut down the engine

Engine Starting, Operation, and Shutdown

if oil pressure does not build within approximately ten seconds. Check to determine the cause of the problem. Operating the engine with no oil pressure will damage the engine.

6. It is not necessary to idle the engine before engaging or starting the operation, but load should be applied gradually during the warm-up period until the oil temperature reaches 140°F (60°C).
7. Apply load gradually during the warm-up period.

NOTICE

If the oil pressure gauge indicates no oil pressure, shut down the engine within approximately ten seconds to avoid engine damage.

8. Check the oil pressure gauge for any drop in lubricating oil pressure or mechanical malfunction in the lubricating oil system. Minimum oil pressure at idle is 7 psi (50 kPa).

Cold-Weather Starting

See the engine manufacturer's operation manual for starting aids that are approved for specific engines.

Starting After Extended Shutdown

Before engine start-up, complete the engine pretrip inspections in [Chapter 22](#).

NOTICE

Failure to eliminate water-diluted lubricating oil may lead to serious engine damage at startup.

An engine in storage for an extended period of time (over winter, for example) may accumulate water in the oil pan through normal condensation of moisture on the internal surfaces of the engine. Oil diluted by water cannot provide adequate bearing protection at start-up. For this reason, change the engine oil and filters after extended storage.

Engine Operation

Safety and Environmental Considerations



Do not operate the engine in an area where flammable vapors such as gasoline or diesel fumes are present. Shut off the engine when in an area where flammable liquids or gases are being handled. Failure to observe these precautions could result in serious injury or death.

All engines in Freightliner vehicles comply with the requirements of the Federal (U.S.) Clean Air Act. Once an engine is placed in service, the responsibility for meeting both state and local regulations is with the owner/operator.

IMPORTANT: Depending upon local jurisdictional emissions guidelines, vehicles that are domiciled outside of the U.S. and Canada may not have engines and/or emissions aftertreatment systems that are compliant with EPA10 or GHG21 regulations.

NOTICE

It is extremely important that the following guidelines be followed for engines that comply with EPA07 or newer regulations, or damage may occur to the aftertreatment device, and the warranty may be compromised.

- Use ultralow-sulfur diesel with 15 ppm sulfur content or less.
- Do not use fuel blended with used engine lube oil or kerosene.
- Use only engine lube oil with a sulfated ash level less than 1.0 wt%; API CJ-4, CK-4, and FA-4 oils meet this requirement.

A Top Tier™ compliant fuel is recommended. Look for the symbol that denotes a Top Tier compliant fuel; see [Fig. 9.3](#).

Engine Starting, Operation, and Shutdown



Fig. 9.3, Top Tier Fuel Symbol

Adequate maintenance of the engine and the diesel particulate filter (DPF) are the responsibility of the owner/operator, and are essential to keep the emission levels low. Good operating practices, regular maintenance, and correct adjustments are factors that help keep emissions within the regulations.

The driver should be familiar with the vehicle warning system in order to bring the vehicle to a safe stop if the engine malfunctions. If the driver doesn't understand how the warning system works, an engine shutdown could occur, causing a safety hazard. See [Chapter 10, Optional Engine Systems](#) for more information.

Engine Break-In

Each engine must pass a full-load operating test on a dynamometer before shipment, thereby eliminating the need for a break-in. Before running the engine for the first time, follow the instructions in the manufacturer's engine operation manual.

Normal Operation

WARNING

Do not operate the engine in an area where flammable vapors such as gasoline or diesel fumes are present. Shut off the engine when in an area where flammable liquids or gases are being handled. Failure to observe these precautions could result in serious injury or death.

Every engine has an operating range in which it performs most efficiently. The operating range extends from maximum torque rpm at the low end, to engine rated speed at the high end. Most engines deliver best fuel economy when operated in the low- and mid-speed segments of the efficiency range and produce maximum horsepower at rated speed, which is also the recommended maximum speed of the engine. For further engine-specific information, refer to the engine manufacturer's operation manual.

Prolonged idling of engines is not recommended, and is illegal in some states. Idling produces sulfuric acid that is absorbed by the lubricating oil, and eats into bearings, rings, valve stems, and engine surfaces. If you must idle the engine for cab heating or cooling, use the high idle function of the cruise control switches. An idle speed of 900 rpm should be enough to provide cab heat in ambient temperatures that are above freezing.

If the engine is programmed with an idle shutdown timer, 90 seconds before the preset shutdown time, the CHECK engine light begins to flash at a rapid rate. If the position of the clutch pedal or service brake changes during this final 90 seconds, the idle shutdown timer is disabled until reset.

Cold-Weather Operation

Satisfactory performance of a diesel engine operating in low ambient temperatures requires modification of the engine, surrounding equipment, operating practices, and maintenance procedures. The lower the temperature, the greater the amount of modification required. For service products approved for use in cold weather for your engine, see the engine manufacturer's engine operation manual.

If satisfactory engine temperature is not maintained, maintenance costs increase due to greater engine wear. If the engine coolant gets too cold, raw fuel washes the lubricating oil off the cylinder walls and dilutes the crankcase oil, causing poor lubrication to all moving parts of the engine.

If the engine is in good mechanical condition and the precautions necessary for cold-weather operation are taken, ordinary cold weather does not cause difficulty in starting or loss of efficiency.

The following points are important to observe when operating in cold weather.

- Check for cracks in the battery cases, for corrosion of the terminals, and for tightness of the cable clamps at the terminals.
- Charge the batteries to full capacity. Replace damaged batteries.
- If equipped, turn off the load disconnect switch after the engine is shut down to prevent battery discharge.
- Have the alternator output checked at an authorized Freightliner service provider.
- Check the condition and tension of the drive belts.

Engine Starting, Operation, and Shutdown

- Refer to the engine manufacturer's operation manual for recommended heaters, low-viscosity lubricating oils, winter-grade fuels, and approved coolants.
- Periodically check the coolant mixing ratio (concentration of antifreeze in the coolant). Add more if necessary.
- At outside temperatures below -4°F (-20°C), a coolant preheater is recommended.

NOTICE

For Detroit engines (EPA07 and newer), use of a winterfront is not recommended, as it can cause false fault codes with the engine and aftertreatment system, and possible emission component failures.

If using a winterfront, leave at least 25% of the grille opening exposed in sectioned stripes that run perpendicular to the charge-air-cooler tube-flow direction. This assures even cooling across each tube, and reduces header-to-tube stress, and possible chance of component failure. For engine-specific guidelines, see below:

Cummins engines: A winterfront may be used to improve cab heating while idling, and only when the ambient temperature remains below 10°F (-12°C).

Detroit engines: Use of a winterfront is not recommended. Using a winterfront can cause excessive fan run time, increased fuel consumption, and failure of the DEF system heaters to operate correctly, resulting in fault codes, poor performance, and power reduction. A winterfront should only be used temporarily in the following situations:

- To improve cab heating while idling in an extremely cold ambient temperature;
- When the ambient temperature remains below -22°F (-30°C) and the engine is unable to maintain a running coolant temperature of 175°F (80°C) during normal over-the-road operation.

High-Altitude Operation

Engines lose horsepower when operated at high altitude because the air is too thin to burn as much fuel as at sea level. This loss equals about three percent for each 1000 ft (300 m) altitude above sea level for a naturally aspirated engine.

All engines used on Freightliner vehicles are altitude-compensated by the use of a turbocharger. This reduces smoky exhaust at high altitudes, requires less downshifting, and allows the engine to make better use of its fuel. Nevertheless, shift gears as needed to avoid excessive exhaust smoke.

Engine Shutdown

1. With the vehicle stopped, set the parking brake and place the transmission in neutral.

NOTICE

Idle the engine one to two minutes before shutting it down. After hard operation, shutting down the engine without idling may cause damage to the turbocharger.

2. Allow the engine to idle one to two minutes before shutting it down. This allows the lubricating oil and the coolant to carry heat away from the combustion chambers, bearings, shafts, and seals.
3. Turn off the ignition switch and shut down the engine.

Engine Protection—Warning and Shutdown

The driver should be familiar with the vehicle warning system in order to bring the vehicle to a safe stop if necessary. If the driver doesn't understand how the warning system works, they may not be able to utilize the advantage of the advance warning system to pull over appropriately.

The engine begins a warning and derate and/or shutdown process if the engine coolant temperature, coolant level, engine oil pressure, or exhaust aftertreatment system (ATS) reach preset levels. On some engines, the warning process begins when the engine oil temperature, engine coolant temperature, or the intake air temperature reach preset levels. Detroit™ engines may also begin the warning and shutdown process if water is detected in the fuel.

See the engine manufacturer's operation manual for specific details for your vehicle. See [Chapter 13](#) for the warning and shutdown modes associated with the ATS.

Electronic engine protection can be specified as either SHUTDOWN or WARNING and DERATE.

Engine Starting, Operation, and Shutdown

WARNING

When the STOP engine or CHECK engine lamp illuminates, most engines are programmed to shut down automatically within 30 seconds. The driver must immediately move the vehicle to a safe location at the side of the road to prevent causing a hazardous situation that could cause bodily injury, property damage, or severe damage to the engine.

In SHUTDOWN mode, the red STOP engine lamp illuminates when the problem is serious enough to reduce power or speed. See Fig. 9.4. Engine power ramps down, then the engine shuts down if the problem continues while in derate mode. The driver has 30 or 60 seconds (depending on the critical fault type) after the STOP engine lamp illuminates to move the vehicle safely off the road. If the vehicle cannot be moved to a safe location within that time, turn the ignition switch to OFF for at least five seconds, then restart the engine. Repeat this action until the vehicle is safely off the road.

NOTE: In addition to the warning lamp, the driver display screen presents a warning message when the engine is in SHUTDOWN mode. See Fig. 9.5. For vehicles with Detroit engines only, the time remaining before shutdown is displayed.

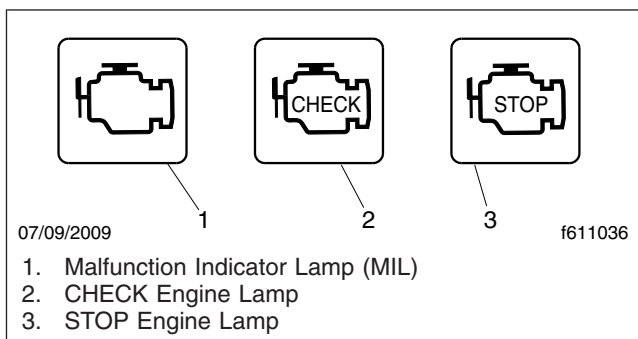

Fig. 9.4, Engine Warning Lamps

Do not operate the vehicle further until the problem causing the shutdown has been corrected.

Some vehicles may have a shutdown override switch, which can be used to momentarily override the shutdown sequence. This switch resets the shutdown timer, restoring power to the level before the derate. The switch must be pressed again after five seconds to obtain a subsequent override. See Fig. 9.6.



Fig. 9.5, Shutdown Alert

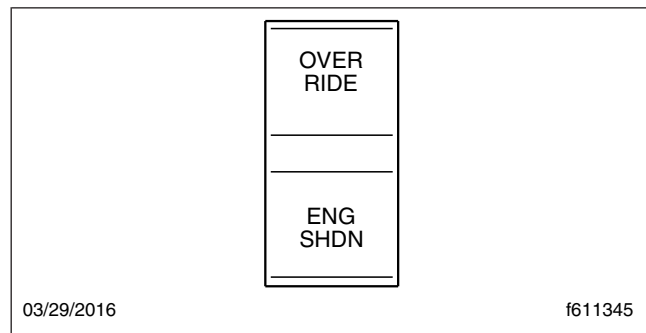

Fig. 9.6, Shutdown Override Switch

NOTICE

When the derate process begins, immediately get the vehicle serviced in order to prevent severe damage to the engine.

Detroit engines may begin a warning and derate process if water is detected in the fuel, or for high engine coolant temperature. In WARNING and DERATE mode, the CHECK engine, STOP engine, or MIL lamp illuminates to indicate an engine problem that requires service and the engine controls begin a derate of engine output. Continuing to run the engine while it is in derate mode may cause severe damage to the engine.

10

Optional Engine Systems

Engine Idle Limiting	10.1
Optimized Idle®	10.1
Power Takeoff (PTO) Governor	10.3

Optional Engine Systems

Engine Idle Limiting

Idle Shutdown Timer

This feature is an optional 1- to 100-minute idle shutdown system with a timer on the driver display screen. Its purpose is to conserve fuel by eliminating excessive idling. Idle shutdown timing and parameters are programmable. See the engine manufacturer's operation manual for specific details for your vehicle.

Optimized Idle®

Optimized Idle is an optional feature on vehicles equipped with Detroit engines. Optimized Idle reduces engine idle time by running the engine only as required when the vehicle is parked.

Optimized Idle automatically shuts down and restarts the engine as needed to:

- Keep the engine oil temperature between programmed limits;
- maintain battery voltage;
- keep the cab and sleeper areas at the thermostat setting; and
- in coordination with the Dual HVAC system (if equipped), maintain the battery and assist in HVAC.

The benefits of the system include reduced engine idle time, fuel savings, reduction of exhaust emissions and noise, increased starter and engine life, and a reduced chance of dead batteries.

Optimized Idle operates in the following modes:

- Cold startability mode and battery mode: Both modes keep the battery charged and engine oil temperature between programmed limits.
- Interior comfort mode (for sleeper cabs without a Dual HVAC system): Keeps the cab and sleeper at a constant preset temperature, in addition to all functions available in cold startability and battery modes. Extended and continuous run modes allow the engine to keep running longer if necessary.
- Interior comfort mode with a Dual HVAC system: Keeps the cab and sleeper at a constant preset temperature, in addition to all functions available in cold startability and battery modes.

In cold startability mode, Optimized Idle starts the engine when engine oil temperature drops to a programmable preset lower limit. The engine is shut down when engine oil temperature reaches a programmable upper limit, unless the requirements of other active modes require the engine to keep running.

In battery mode, the engine runs for 2 hours before shutting down. On vehicles without a Dual HVAC system, the engine runs an additional 2 hours in extended mode if necessary, and continuously in continuous mode. When in continuous mode, the driver display indicates Optimized Idle status as 'continuous battery mode.' Continuous mode may indicate a problem, such as a bad battery.

Interior comfort mode controls the temperature set point, which is the desired temperature of the cab and sleeper, and the comfort zone, which is the allowed temperature deviation from the set point before the engine starts.

Interior comfort mode with a Dual HVAC system operates with the following parameters regarding the set point and comfort zone:

- If the bunk area temperature reaches more than 10°F (5.5 °C) above the set point the comfort zone is exceeded and the Dual HVAC system immediately requests the engine to start for comfort support cooling.
- Bunk area temperatures 5 to 10°F (2.8 to 5.5°C) above the set point for over twenty minutes causes the Dual HVAC system to request the engine to start for comfort support cooling.
- If the bunk area temperature drops to more than 10°F (5.5 °C) below the set point, the comfort zone is exceeded and the Dual HVAC system immediately requests the engine to start for comfort support heating.
- Temperatures 5 to 10°F (2.8 to 5.5 °C) below the set point for over twenty minutes causes the Dual HVAC system to request the engine to start for comfort support for heating.

In extreme ambient conditions, comfort mode may stay on continuously.

NOTE: If the mode settings are changed while in one mode, the system may continue running in another mode.

When Optimized Idle is on, it may turn off these functions to reduce stress on the batteries:

- Cab climate control fan
- Sleeper climate control fan
- Mirror heat
- Fuel/water separator heat
- Seat heat
- Advertising light
- Auxiliary circulation fan (windshield)
- Air dryer

Activating Optimized Idle

The vehicle must be in neutral gear, the hood latched, and the park brake set for Optimized Idle to work. Failure to meet these conditions result in a checklist pop-up screen showing both the met and unmet conditions. See [Fig 10.1](#).

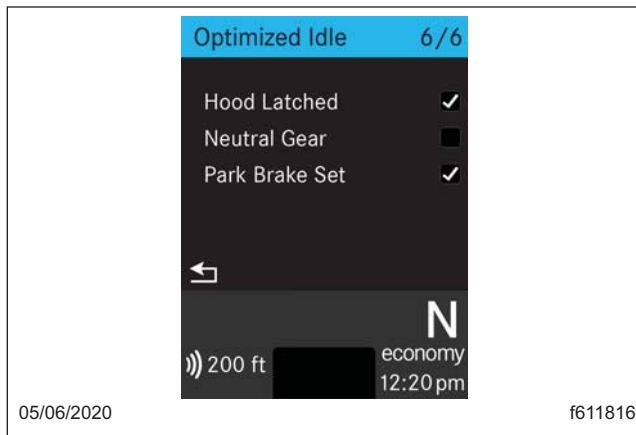

Fig. 10.1, Optimized Idle Activation Conditions Pop-Up

Dismiss the pop-up screen, fix the issue(s), and restart Optimized Idle.

NOTE: Turning the sleeper HVAC fan off turns off the interior comfort mode until the fan is turned back on.

1. Set the parking brake.
2. If open, close and secure the hood.
3. Allow the engine to idle if it is running. If the engine is not running, turn the key to the ON position.
4. Put the transmission in neutral.
5. Navigate to the Optimized Idle screen on the driver display. See [Fig. 10.2](#).

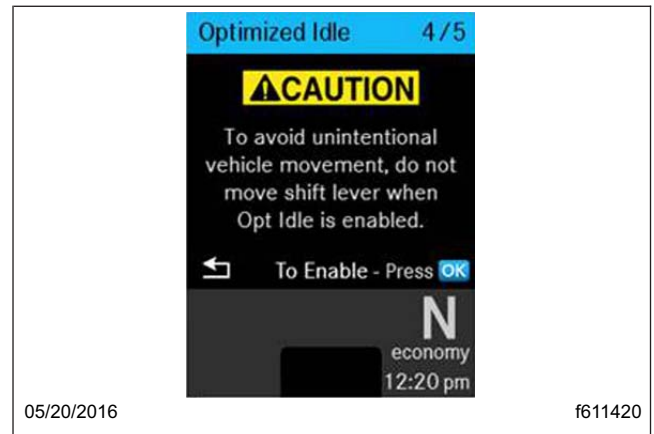

Fig. 10.2, Optimized Idle Start Screen

6. Press OK on the steering wheel switch pod to view the mode option screen. See [Fig. 10.3](#).
7. Select OK to enable Optimized Idle, and, if desired, turn on the interior comfort mode (sleeper cabs only). The current Optimized Idle state is displayed. See [Fig. 10.4](#).

When Optimized Idle is active, the Optimized Idle telltale illuminates at the bottom of the driver display. See [Fig. 10.5](#).

If Optimized Idle fails to start, see the driver display for information.

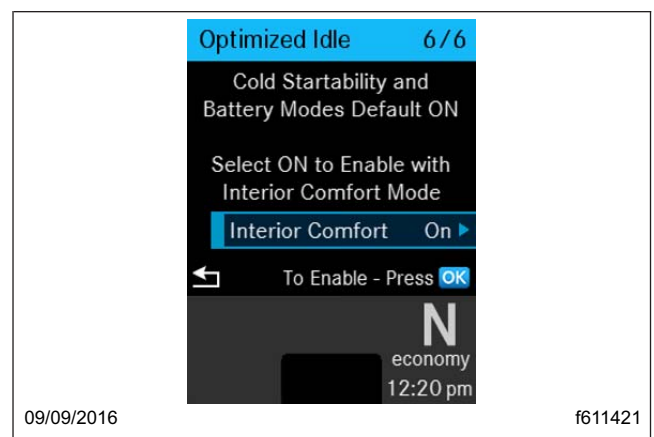

Fig. 10.3, Optimized Idle Mode Selection Screen

8. If the interior comfort mode is activated (sleeper cabs only), set the desired temperature and fan speed on the sleeper HVAC controls.

The allowable temperature range for Optimized Idle operation is 65 to 80°F (18 to 27°C).

Optional Engine Systems

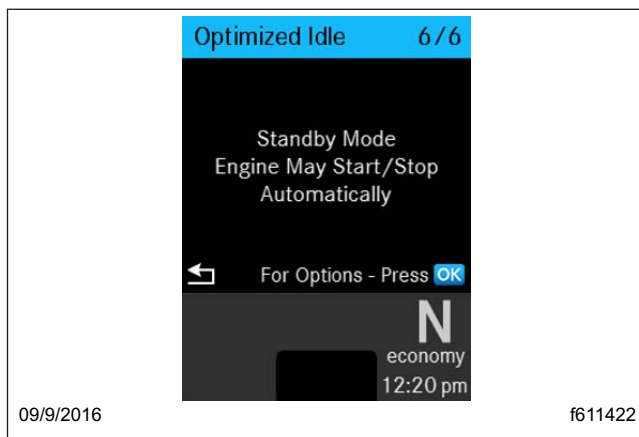

Fig. 10.4, Optimized Idle State Screen

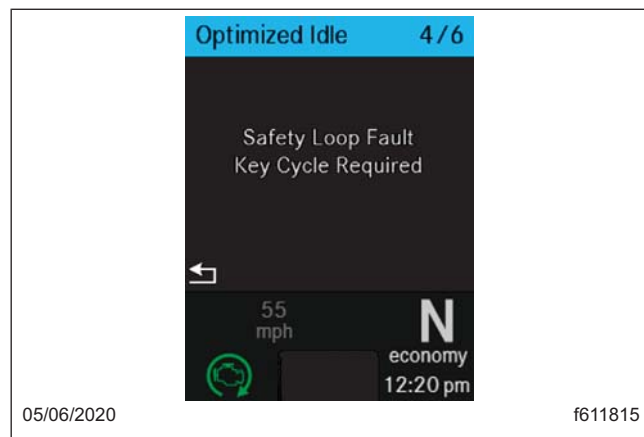

Fig. 10.6, Safety Loop Pop-Up

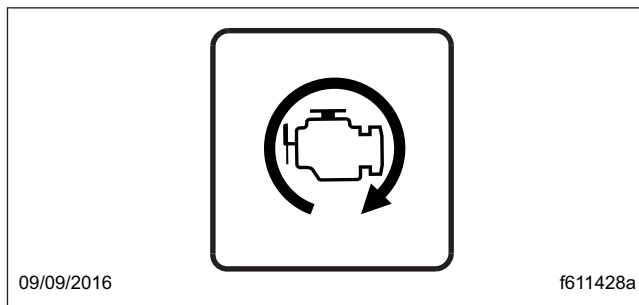

Fig. 10.5, Optimized Idle Telltale

Optimized Idle operates the engine, starting and turning it off as needed to maintain battery charge, engine oil temperature, and cab/sleeper temperature.

Reactivating Optimized Idle

If the hood is opened or the vehicle is put into gear while Optimized Idle is running, the system enters a safety loop and a pop-up appears. See Fig. 10.6. Restoring operating conditions (e.g. closing the hood or setting the transmission in neutral) and performing a key cycle allows you to reactivate Optimized Idle.

Deactivating Optimized Idle

Optimized Idle can be shut down by:

- using the Optimized Idle menu screens on the driver display;
 - turning off the ignition;
 - using the drive-away feature, as follows.
1. If the engine is running: Release the parking brakes, put the transmission in gear (automated/

automatic transmissions), or depress the clutch (manual transmissions).

If the engine is not running: Start the engine. Release the parking brakes, put the transmission in gear (automated/automatic transmissions), or depress the clutch (manual transmissions).

2. Let the engine return to base idle. The telltale turns off. Optimized Idle is now disabled.

Power Takeoff (PTO) Governor

WARNING

To avoid injury, do not install a PTO that is not Detroit Diesel approved onto a Detroit™ Transmission. Use of a non-Detroit Diesel approved PTO with a Detroit Transmission could result in unintended operation which could lead to severe personal injury.

Engine power takeoffs (PTO) tap into engine power to run auxiliary devices, such as hydraulic pumps that power additional equipment.

The following are general guidelines for operating a PTO.

1. Set the parking brake and put the transmission in neutral.
2. Press the dash PTO switch. Release the switch when the light begins to blink.

When the light illuminates steadily, the PTO is engaged and ready to operate. In stationary mode, the vehicle must remain in neutral with the parking brake set.

3. To activate mobile mode, depress the service brake pedal, then shift from neutral to reverse, 1st, or 2nd gear. The clutch opens and the PTO disengages for a moment.
4. Touch the accelerator pedal to close the clutch and engage the PTO in mobile mode. The PTO may be operated with the transmission in neutral or reverse, and 1st and 2nd gears only.

NOTE: Do not attempt to change gears while the vehicle is moving. The transmission ignores the request.

5. To deactivate mobile mode, bring the vehicle to a stop. The clutch opens and shuts down power to the PTO.
6. To resume stationary mode, shift to neutral. The PTO engages.
7. To deactivate PTO, press the PTO switch again. When the light in the switch goes out, power to the PTO is shut off.

After the Power Take Off (PTO) is engaged using the PTO switch, available PTO speeds are indicated by check boxes on the Power Take Off Screen in the instrumentation unit. See [Fig. 10.7](#).

PTO speed 1 is selected initially. If a speed is out of range it is not available to select. If a PTO speed is available for customization, it is indicated with a Customize option.

PTO Instrumentation Unit Controls

If configured for ICU speed control, PTO screens can be accessed under the Vehicle Settings menu.



Fig. 10.7, Quick Access Screen: Power Take Off (PTO)

Brake Systems

Air Brake System	11.1
Engine Brake	11.3
Exhaust Braking Systems	11.4
Hydraulic Brake System	11.7
Meritor WABCO® Antilock Braking System	11.7

Brake Systems

Air Brake System

A dual air brake system consists of two independent air systems that use a single set of brake controls. Each system has its own reservoirs, plumbing, and brake chambers. The primary system operates the service brakes on the rear axle; the secondary system operates the service brakes on the front axle. Service brake signals from both systems are sent to the trailer.

WARNING

Do not operate the vehicle with the front brakes backed off or disconnected. Backing off or disconnecting the front brakes will not improve vehicle handling and may lead to loss of vehicle control, resulting in property damage or personal injury.

Air Brake System, General Information

The warning light and buzzer come on if air pressure drops below 64 to 76 psi (441 to 524 kPa) in either system. If this happens, check the dual system air pressure gauge to determine which system has low air pressure. Although the vehicle's speed can be reduced using the brake pedal, either the front or rear service brakes do not operate at full capacity, causing a longer stopping distance. Bring the vehicle to a safe stop and have the air system repaired before continuing.

IMPORTANT: In the event of a total loss of service brakes with full system air pressure, use the parking brake control valve (yellow knob) to bring the vehicle to a complete stop in the safest location possible.

Before a vehicle with insufficient system air pressure can be moved, the spring parking brakes must be released by applying an external air source at the gladhands, or by manually caging the spring parking brakes.

WARNING

Do not cage the spring parking brakes and then drive the vehicle. There would be no means of stopping the vehicle, which could result in serious personal injury or vehicle damage. Before caging the spring parking brakes, make

the connection to a towing vehicle or chock the tires.

After correcting the brake system problem, uncage the spring parking brakes before resuming normal vehicle operation.

Primary Air Brake System

Loss of air pressure in the primary air system causes the rear service brakes to become inoperative. The secondary air system continues to operate the front brakes and the trailer brakes (if equipped).

Secondary Air System

Loss of air pressure in the secondary air system causes the front axle brakes to become inoperative. The primary air system continues to operate the rear service brakes and the trailer brakes (if equipped).

Air Brake System Operation

Before driving your vehicle, allow time for the air compressor to build up a minimum of 100 psi (689 kPa) pressure in both the primary and secondary systems. Monitor the air pressure system by observing the dual system air pressure gauge and the low-air-pressure warning light and buzzer. The warning light and buzzer shut off when air pressure in both systems reaches 64 to 76 psi (441 to 524 kPa).

IMPORTANT: Before driving the vehicle, secure all loose items in the cab so that they do not shift forward during a full brake application. Make sure all passengers are wearing seat belts.

During normal brake stops, depress the brake pedal until braking action slows down the vehicle. Increase or decrease the pressure on the pedal so that the vehicle comes to a smooth, safe stop. Apply the parking brake if the vehicle is to be parked.

IMPORTANT: An air brake proportioning system may be used in tractor air brake systems when the vehicle is not equipped with antilock braking system (ABS). When operating in bobtail mode, the rear brake chambers (on which the axle load has been greatly reduced) receive reduced (proportional) air pressure, while the front axle brake chambers receive full (normal) air pressure. This results in a different brake pedal "feel," as the pedal seems to require more travel and/or effort to slow or stop the vehicle.

However, the air brake proportioning system actually improves vehicle control when the tractor is in bobtail mode. When the tractor is towing a trailer, the rear brake chambers receive full (normal) application air pressure.

When parking a vehicle attached to a trailer that does not have spring parking brakes, apply the tractor parking brake. Chock the trailer tires before disconnecting the vehicle from the trailer.

WARNING

If a trailer or combination vehicle is not equipped with spring parking brakes, do not park it by pulling out only the trailer air supply valve knob. This would apply only the trailer service brakes. If air were to bleed from the trailer brake system, the trailer brakes would release, possibly causing an unattended runaway vehicle.

NOTICE

Never apply the service and spring parking brakes simultaneously. To do so transmits excessive input force to the brake components, which could damage or cause eventual failure of brake actuating components.

Brake Hand Controls

The trailer brake lever (hand control valve) is used for applying the trailer brakes without applying the truck or tractor service brakes. It is usually mounted on the right-hand control panel. See [Fig. 11.1](#). The valve can be partially or fully applied, but in any partially applied position, it is overridden by a full application of the brake pedal. Moving the lever down applies the trailer brakes, while moving it up releases the trailer brakes. The lever automatically returns to the up position when it is released.

WARNING

Do not use the trailer service brakes for parking; they are not designed for this purpose. If air bleeds out of the trailer air tank during parking, the vehicle could roll, causing serious personal injury or property damage.

The red octagonal-shaped knob in the control panel actuates the trailer air supply valve. See [Fig. 11.1](#). After the vehicle's air hoses are connected to a trailer and the pressure in both air systems is at least 65 psi (448 kPa), the trailer air supply valve must be



11/29/2022

f612193

1. Parking Brake Control
2. Trailer Air Supply Control
3. Hazard Warning Switch
4. Trailer Brake Control

Fig. 11.1, Right-Hand Control Panel

pushed in. It should stay in to charge the trailer air supply system and to release the trailer spring parking brakes.

Pull the trailer air supply valve out before disconnecting a trailer or when operating a vehicle without a trailer.

If pressure in both air systems drops to 20 to 45 psi (138 to 310 kPa), the red trailer air supply valve and yellow parking brake valve automatically pop out, applying both the tractor and trailer spring parking brakes. If the trailer is not equipped with spring parking brakes, the trailer service brakes are applied.

The yellow diamond-shaped knob in the control panel actuates the parking brake valve. See [Fig. 11.1](#). Pulling out the parking brake valve applies both the tractor and trailer spring parking brakes and automatically causes the trailer air supply valve to pop out. Pushing in the parking brake valve releases the tractor parking brakes.

NOTICE

Do not use the spring parking brakes if the service brakes are hot, such as after descending a steep grade. To do so could damage the brakes. Allow hot brakes to cool before using the spring parking brakes.

Do not use the spring parking brakes during freezing temperatures if the service brakes are wet. To do so could cause them to freeze. If the

Brake Systems

brakes are wet, drive the vehicle in low gear and lightly apply the brakes to heat and dry them.

If the trailer is not equipped with spring parking brakes, pulling out the parking brake valve applies the tractor parking brake and the trailer service brakes. When the tractor and trailer parking brakes (or trailer service brakes) are both applied, the trailer brakes are released by pushing in the trailer air supply valve, leaving the tractor parking brake applied. Air pressure in the primary or secondary reservoir must be at least 65 psi (448 kPa) before the tractor spring parking brakes, or the trailer service or spring parking brakes, can be released.

Automatic Slack Adjusters

Automatic slack adjusters should never be manually adjusted except during routine maintenance of the foundation brakes (e.g., replacing shoes), during slack adjuster installation, or in an emergency situation.

When the brake pushrod stroke exceeds the legal brake adjustment limit on a vehicle, there is likely a mechanical problem with the foundation brake components or the adjuster is improperly installed.

Visit a repair facility as soon as possible when brakes equipped with automatic slack adjusters are determined to be out of adjustment.

WARNING

Manually adjusting an automatic slack adjuster to bring the pushrod stroke within legal limits is likely masking a mechanical problem. Adjustment is not repairing. Before adjusting an automatic slack adjuster, troubleshoot the foundation brake system and inspect it for worn or damaged components. Improperly maintaining the vehicle braking system may lead to brake failure, resulting in property damage, personal injury, or death.

Engine Brake

Each engine manufacturer uses a specific engine brake for their engine. Regardless of the manufacturer, the engine brake is operated with the principles outlined in here. Refer to the engine manufacturer's operation manual for details of their particular engine brake product.

WARNING

To avoid injury from loss of vehicle control, do not activate the engine brake system under the following conditions:

- **on wet or slippery pavement, unless the vehicle is equipped with antilock braking system (ABS) and you have had prior experience driving under these conditions;**
- **when driving without a trailer or pulling an empty trailer;**
- **if the tractor drive wheels begin to lock, or there is fishtail motion after the engine brake is activated.**

NOTE: When the engine brake is enabled, the engine brake lamp illuminates in the ICU.

Whenever vehicle braking is required on good road conditions, the engine brake may be used in conjunction with the service brakes. There is no time limit for operation of the engine brake. However, an engine brake does not provide the precise control of, and is not a substitute for, service brakes.

WARNING

Usage of the engine brake as the primary braking system can cause unpredictable stopping distances, that could result in personal injury or property damage. Service brakes are the primary vehicle braking system.

Since the engine brake is most effective at rated engine speed, gear selection is very important. Gearing down the vehicle within the limits of the rated engine speed makes the engine brake more effective. Recommended engine braking speed is above 1800 rpm and below the rated speed.

"Control speed" is the speed at which the engine brake performs 100 percent of the required downhill braking, resulting in a constant speed of descent. The control speed varies, depending on vehicle weight and the downhill grade.

For faster descent, select a higher gear than that used for control speed. Service brakes must then be used intermittently to prevent engine overspeed and to maintain desired vehicle speed.

For slower descent, select a lower gear, being careful not to overspeed the engine. Occasional deactivation of the engine brake may be necessary

to maintain the designated road speed under these conditions.

If the engine is equipped with both cruise control and an engine brake, the engine brake can operate automatically while cruise control is activated. The maximum amount of braking is selected with the engine brake control. When the vehicle returns to the set cruise speed, the engine brake turns off.

The engine brake only operates when the accelerator and clutch pedals are fully released.

ABS has the ability to turn the engine brake off if wheel slip is detected. The engine brake automatically turns back on once wheel slip is no longer detected.

Engine Brake Operation

NOTICE

Do not allow the engine to exceed its governed speed, or serious engine damage could result.

NOTE: Depending on the brake type, the engine brake may be disabled when engine temperature falls below a set level.

The engine brake control is located on the right-hand steering column lever. At the top position, the engine brake is off, and at the three lower positions, the engine brake is on and the intensity (low, medium, high) increases with each step down. See [Fig. 11.2](#).

NOTE: The cruise control system and safety systems may activate the engine brake regardless of the lever position.

NOTE: On vehicles equipped with a Detroit automated transmission, setting the engine brake with the cruise control set activates Deceleration Mode. Setting the cruise control while the engine brake is on activates Descent Control Mode. For information on these modes, see "Cruise Control" in [Chapter 7](#).

Exhaust Braking Systems

Exhaust Brake Switch

The optional exhaust brake is controlled by a dash-mounted rocker switch to help slow the vehicle when the accelerator is released.

To turn the exhaust brake on, press on the upper part of the rocker (at the light inside the switch). The

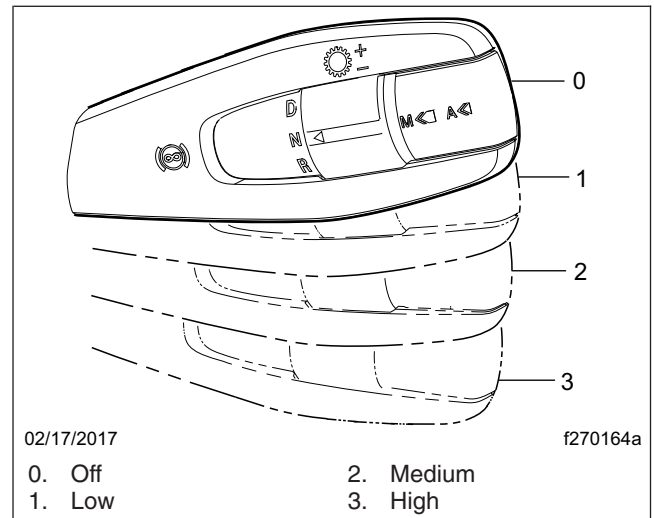

Fig. 11.2, Engine Brake Positions, Right-Hand Steering Column Lever

exhaust brake turns off automatically. See [Fig. 11.3](#) or [Fig. 11.4](#).

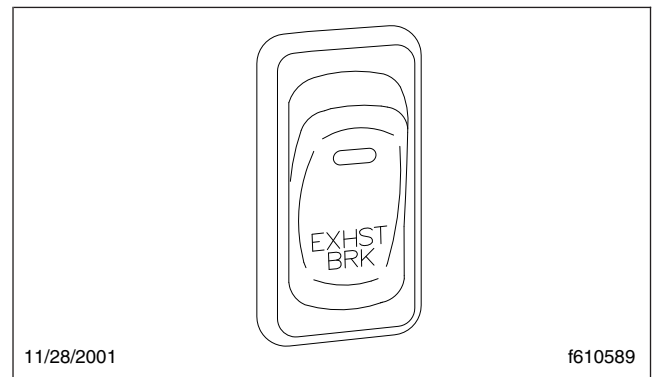

Fig. 11.3, Exhaust Brake Switch

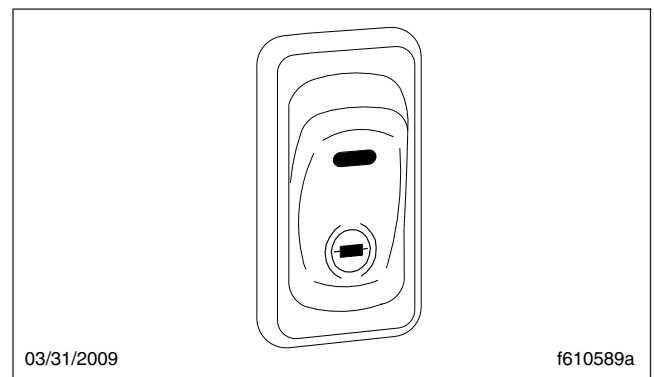

Fig. 11.4, Exhaust Brake Switch

Brake Systems

When the exhaust brake switch is on, an amber LED illuminates inside the switch. When the panel lights are on, the EXHST BRK legend is backlit in green.

Mercedes-Benz Exhaust Brake

An exhaust brake is an optional auxiliary braking system that assists but does not replace the service brake system. The exhaust brake can be used alone or together with the constant-throttle valves for steep or long grades. The exhaust brake switch located on the control panel, in combination with the accelerator and clutch pedals, allows the driver to make maximum use of the exhaust brake in off-highway and mountain driving as well as in traffic or high-speed highway driving.

When only the exhaust brake is installed, a two-position switch on the dash controls the engine braking system. The exhaust brake is only active when the engine speed is between 1100 and 2700 rpm. Depressing the accelerator or clutch pedal deactivates the exhaust brake. The ABS system, when active, also deactivates the exhaust brake.

The exhaust brake is a butterfly valve mounted in the exhaust pipe. When the driver's foot is not on the accelerator pedal and the upper half of the exhaust brake switch is pressed in, with the amber light on the switch illuminated, an air cylinder shuts the butterfly valve, which restricts the flow of exhaust gases and retards the engine. This retarding action is carried through the engine and drivetrain, slowing the vehicle and reducing the need for frequent service brake applications.

Exhaust brakes are not intended for use as the primary braking system during vehicle operation.

Operating Characteristics



Do not use the exhaust brake when driving on slippery or low-traction road surfaces. Failure to follow this precaution could result in a loss of vehicle control and possible personal injury or property damage.

Before starting the engine, make sure that the lower half of the exhaust brake switch is pressed in and the amber light is not illuminated. Do not turn the exhaust brake on until the engine has reached normal operating temperatures.

When you remove your feet from both the accelerator and clutch pedals and the upper half of

the exhaust brake switch is pressed in with the amber light illuminated, the exhaust brake is applied. The following conditions should exist if the brake is operating properly:

- A slight change in the sound of the engine may be noticed when the exhaust brake is applied.
- Exhaust smoke should appear normal.
- Engine temperature should remain in the normal operating range.
- Road speed usually decreases when the exhaust brake is applied during a descent. When the vehicle is carrying a heavy load or the grade is extremely steep, you may need to apply the service brakes occasionally.
- Do not expect a retarding effect similar to sudden hard application of the service brakes. The exhaust brake retards the vehicle with a smooth braking effect.
- During a descent, the tachometer usually shows a drop in rpm, depending on the grade and the vehicle load.
- Depending on the grade and vehicle load, you may or may not feel the retarding force acting against your body when the brake is applied. The retarding force of the brake may not always be noticed, but it is actually preventing the vehicle from going much faster.

Make sure the exhaust brake is turned off before shutting down the engine.

Driving Downhill

While approaching a steep grade, make sure that the upper half of the exhaust brake switch is pressed in, with the amber light illuminated. The exhaust brake comes on as soon as you remove your foot from the accelerator pedal. While going down the grade, use a low enough gear to safely descend with a minimum application of the service brakes. As a general guideline, use the same gear as you would to ascend the hill.

NOTICE

Do not allow the engine to exceed its governed speed, or serious engine damage could result.

Apply the service brakes to reduce the engine rpm or make a slower descent by using a lower gear.

Pacbrake® Exhaust Brake

The Pacbrake exhaust brake is intended as a supplement to the service brakes and will *not* bring the vehicle to a complete stop. The Pacbrake will assist in the control or reduction of road speed in conjunction with, or independent of, the service brakes. The amount of retarding or braking force is controlled by the driver.

Pacbrake Operation (Caterpillar)

The Pacbrake is controlled by the exhaust brake switch and the throttle pedal. All applications are additionally affected, controlled, or governed by engine speed through transmission gear selection. The Allison MD3060 transmission has automatic downshifting when the exhaust brake is requested. See the information on the "Allison World Transmission" later in this chapter.

On some applications, when the Pacbrake is in use, it may be necessary to check that the cruise control is not set and that the throttle is in the idle position.

On some applications, the engine, transmission, cruise control, and the Pacbrake exhaust brake may electronically interact with each other, which automatically operates their functions. Following are some examples of the programmed options that may be available with the cruise control in the on position:

- The coast mode engages the Pacbrake when the service brake is applied and disengages when the service brake is released.
- The latch mode engages the Pacbrake when the service brake is applied and the Pacbrake remains on after the service brake is released. The Pacbrake is disengaged when another input (depressing the throttle or clutch, engine speed drops below 800 rpm, or the exhaust brake switch is turned off) is supplied.
- The manual mode does not require the cruise control switch to be on, and operates the Pacbrake manually at the driver's discretion.

The amount of braking power the engine will develop is related to the speed (rpm) of the engine. The higher the engine rpm, the greater the retarding power.

Certain conditions may require that the transmission be downshifted in order to generate adequate rpm for the amount of retarding power required. Pacbrake exhaust brakes are designed and approved for safe use at 300 rpm above the engine's maximum

governed rpm. Refer to individual engine manufacturer's specifications.

The Pacbrake will function best if it is used all of the time. However, if the vehicle is used inconsistently or seasonally, it may be necessary to perform a preventive maintenance procedure.

1. With the engine shut down, use any oil-free or nonpetroleum-based high-heat lubricant, and spray or coat a sufficient amount on the restrictor valve shaft and the attaching locations at each end of the actuation cylinder. See [Fig. 11.5](#).

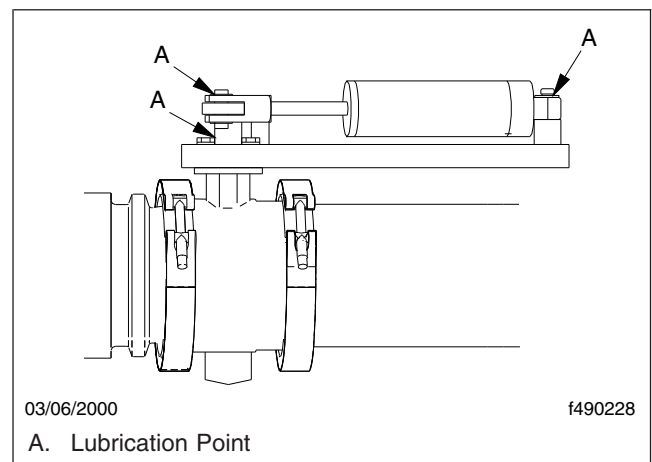

Fig. 11.5, Pacbrake Exhaust Brake and Air Cylinder

2. With your hands or a pair of pliers, motion the valve several times to distribute the lubricant down the shaft and the attaching locations.

NOTE: Starting the engine and idling for short periods of time is not recommended. During a cold engine start-up, enough moisture is developed within the engine and the exhaust system to create a corrosion hazard that could affect the future operation of the Pacbrake. The brake housing may trap water in the valve shaft bore causing corrosion in an improperly functioning or nonfunctioning brake. If it is necessary to periodically start the engine, it is recommended that normal operating temperatures be attained before shutting down the engine.

Allison World Transmission

Pacbrake exhaust brakes used with the Allison World Transmission MD series, are interfaced with the transmission electronic control module (ECM). An

Brake Systems

exhaust-brake-enabled transmission ECM will usually provide converter lockup in gears two through six. Effective exhaust braking begins when the transmission automatically downshifts into fifth gear (62 mph or less). Once on, the Pacbrake exhaust brake will control road speed and/or slow the vehicle sufficiently that the transmission will automatically downshift, if necessary, to Allison's preselect mode.

The preselect mode is normally assigned to second gear; however, the transmission can be reprogrammed by an Allison Transmission Distributor to third or fourth gear, should the operator desire. If additional retarding power is required before the automatic downshifting occurs, you can select a lower transmission gear on the Allison shift selector.

Hydraulic Brake System

Hydraulic Brake System, General Information

The hydraulic brake system includes a power booster, master cylinder, reservoir, hydraulic lines, a brake rotor on each wheel hub, and a brake caliper and pad assembly at each rotor.

The master cylinder controls braking power to the front and rear brakes. The Bendix Hydro-Max® power booster is attached to the rear of the master cylinder and is connected to the power steering system (which provides pressurized power steering fluid). An electrical backup pump operates if there is inadequate fluid flow from the power steering pump to the power booster.

The brake system warning light illuminates if there is a problem within the system. Bring the vehicle to a safe stop and correct the problem before continuing operation of the vehicle.

Hydraulic Brake System Operation

IMPORTANT: Make sure that the fluid level in the master cylinder reservoirs is at the bottom of the fill-neck. See [Fig. 11.6](#). Use only heavy-duty brake fluid, DOT 3, in the hydraulic brake system.

IMPORTANT: Before driving the vehicle, secure all loose items in the cab so that they do not shift forward during a full brake application. Make sure all passengers are wearing seat belts.

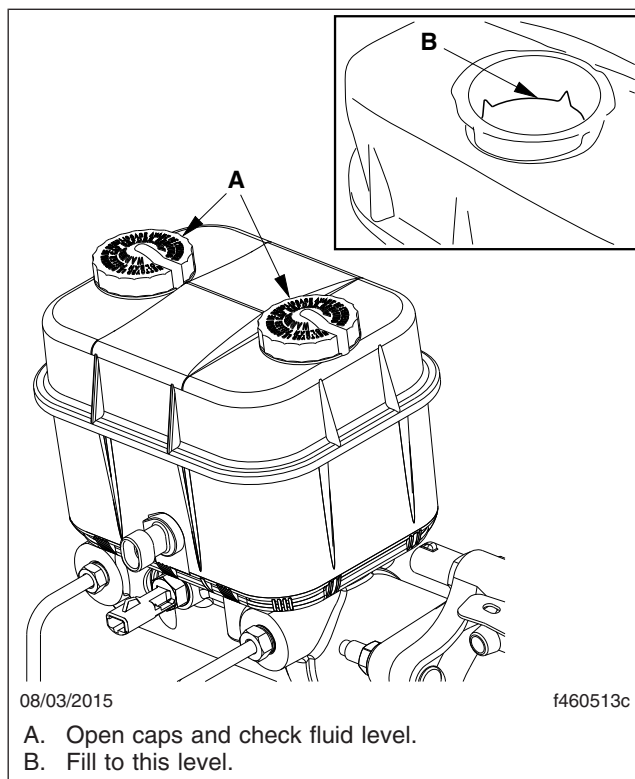

Fig. 11.6, Hydraulic Brake Fluid Reservoir (Bosch reservoir shown, Bendix reservoir similar)

During normal brake stops, depress the brake pedal until braking action slows down the vehicle. Increase or decrease the pressure on the pedal so that the vehicle comes to a smooth, safe stop. Apply the parking brake if the vehicle is to be parked.

When parking a vehicle attached to a trailer, apply the tractor parking brake. Chock the trailer tires before disconnecting the vehicle from the trailer.

Meritor WABCO® Antilock Braking System

The Meritor WABCO Antilock Braking System (ABS) is an electronic wheel speed monitoring and control system that works with the brake system. ABS passively monitors vehicle wheel speed at all times, and controls wheel speed during emergency stops or wheel lock situations.

NOTICE

An accumulation of road salt, dirt, or debris on the ABS tone wheels and sensors can cause the

ABS warning light to come on. If the ABS light does come on, the tone rings and sensors should be inspected for corrosion and serviced if necessary. The service should include cleaning of the tone rings and sensors. If any tone ring on a vehicle shows severe corrosion, all tone rings on that vehicle should be replaced.

During winter months in areas where corrosive materials are used on the highways, periodically clean the underside of the vehicle, including the tone rings and sensors, to ensure proper ABS function and to protect the components from corrosion. Clean more frequently when unusually corrosive chemicals are being used.

IMPORTANT: For proper ABS system operation, do not change tire sizes. The sizes of the tires installed during production are programmed into the electronic control unit (ECU). Installing different-sized tires could result in a reduced braking force, leading to longer stopping distances.

The ABS includes signal-generating tone wheels and sensors located in the wheel hubs of each sensed wheel. The sensors transmit vehicle wheel speed information to an electronic control unit ECU located behind the center dash. The ECU's main circuit interprets the speed sensor signals and calculates wheel speed, wheel retardation, and a vehicle reference speed. If the calculations indicate wheel lockup, the main circuit signals the appropriate modulator valve to reduce braking pressure. During emergency braking, the modulator valve alternately reduces, increases, or maintains air pressure supply in the brake chamber to prevent front and rear wheel lockup.

The Meritor WABCO ABS combines one front-axle control channel with one rear-axle control channel to form one control circuit. For example, the sensor and modulator valve on the left-front axle form a control circuit with the sensor and modulator valve on the right-rear axle.

The ECU has a safety circuit that constantly monitors the wheel sensors, traction control valve (if equipped), modulator valves, and the electrical circuitry. If the safety circuit senses a failure in any part of the ABS, the tractor warning lamp (TRACTOR ABS) illuminates and the control circuit where the failure occurred is switched to normal braking action. The remaining control circuit retains the ABS effect. Even if the ABS is completely inoperative, normal braking ability is maintained.

The ABS indicator lamp illuminates after the ignition is switched on and goes out within three seconds if the system is functioning correctly. If the ABS indicator lamp does not illuminate, or does not go out after three seconds, have the vehicle serviced before operation.

During emergency or reduced-traction stops, fully depress the brake pedal until the vehicle comes to a safe stop. *Do not pump the brake pedal.* With the brake pedal fully depressed, the ABS controls all wheels to provide steering control and a reduced braking distance.

Although the ABS improves vehicle control during emergency braking situations, the driver still has the responsibility to change driving styles depending on existing traffic and road conditions. For example, the ABS cannot prevent an accident if the driver is speeding or following too closely.

Trailer ABS Compatibility

The Meritor WABCO ABS is designed to communicate with a trailer ABS, if they are compatible. Compatibility is shown with the illumination of the TRAILER ABS lamp during vehicle start-up and fault detection.

The TRAILER ABS lamp does not illuminate unless a compatible trailer is connected to the tractor. The dash-mounted lamp operates as follows when a compatible trailer is properly connected to the tractor:

- When the ignition key is turned to the ON position, the TRAILER ABS lamp illuminates momentarily, then turns off.
- If the lamp illuminates momentarily during vehicle operation, then shuts off, a fault was detected and corrected.
- If the lamp illuminates and stays on during vehicle operation, there is a fault with the trailer ABS. Repair the trailer ABS system immediately to ensure full antilock braking capability.

IMPORTANT: If a compatible trailer is connected, and the lamp is not illuminating momentarily when the ignition key is turned to the ON position, it is possible that the lamp is burnt out.

Automatic Traction Control

Vehicles with electronic engines and ABS may have Automatic Traction Control (ATC). On these vehicles,

Brake Systems

the ATC system automatically limits wheel spin during reduced-traction situations. In normal braking applications, the standard air brake system is in effect.

An additional solenoid valve is installed. During reduced-traction situations, the ATC solenoid valve controls air pressure to the modulator valves and they in turn increase, hold, or reduce pressure to the appropriate brake chambers to provide better traction whenever wheel spin occurs.

When the ATC system is in the NORMAL mode, it applies gentle braking to the spinning wheel, to feed power to the wheel(s) with better traction. If both wheels are spinning, the system signals the engine to reduce power.

ATC includes a deep snow and mud option to increase available traction on extra soft surfaces like snow, mud, or gravel. A momentary contact rocker switch labeled ATC is located on the dash. Pressing the switch temporarily allows more wheel spin. The activation of the deep snow and mud option is indicated by a flashing WHEEL SPIN lamp. Pressing the switch again cycles the system back to normal operation.

NOTICE

The deep snow and mud option is intended to be used under specific slippery conditions that require momentary increased wheel spin. Using this option for an extended period of time may damage the vehicle brake system.

After the ignition switch is turned on, the TRACTOR ABS lamp and the WHEEL SPIN indicator lamp illuminate for about three seconds. After three seconds, the warning lights go out if all of the tractor's ABS components are working.

IMPORTANT: If any of the ABS warning lights do not work as described above, or illuminate while driving, repair the ABS immediately to ensure full antilock braking capability.

12

Steering System

Steering System	12.1
-----------------------	------

Steering System

Steering System

WARNING

Driving the vehicle without the power-assist feature of the steering system requires much greater effort, especially in sharp turns or at low speeds, which could result in an accident and possible injury.

NOTICE

Never steam clean or high-pressure wash the steering gear. Internal damage to gear seals, and ultimately the steering gear, can result.

NOTICE

Avoid turning the tires when they are against a curb, as this places a heavy load on steering components and could damage them.

The power steering system includes the power steering gear, hydraulic hoses, power steering pump, reservoir, steering wheel and column, and other components.

Models equipped with dual steering are also equipped with a separate hydraulic power cylinder on the right side of the front axle or a right-hand secondary gear.

The power steering pump, driven by the engine, provides the power assist for the steering system. If the engine is not running, there is no power assist.

If the power-assist feature does not work due to hydraulic fluid loss, steering pump damage, or another cause, bring the vehicle to a safe stop. Do not drive the vehicle until the cause of the problem has been corrected.

Drivers should carefully use the power available with a power steering system. If the front tires become lodged in a deep hole or rut, drive the vehicle out instead of using the steering system to lift the tires out of the hole.

Steering Wheel Adjustment Check

When there is no load on the vehicle and the front tires are pointed straight ahead, the standard steering wheel spokes should be at the 3 o'clock and 9 o'clock positions or within 10 degrees of these positions. See [Fig. 12.1](#).

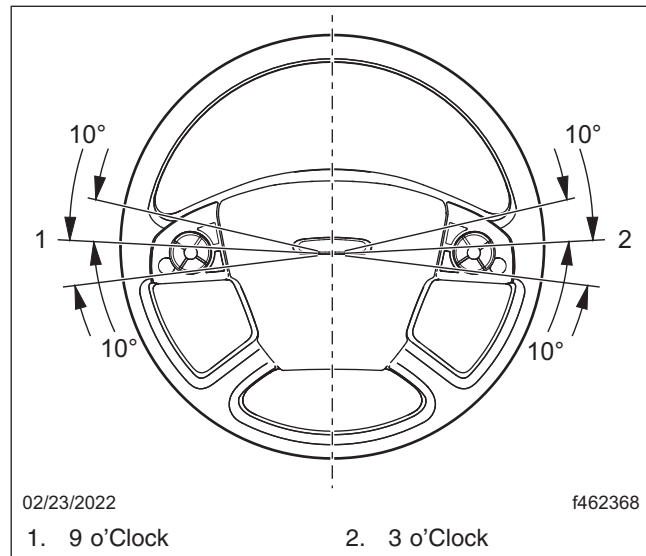

Fig. 12.1, Steering Wheel Centered

If the steering wheel is not in the position above when checked, take the vehicle to an authorized Freightliner dealership to have the steering adjusted.

13

Emissions

Greenhouse Gas Emissions and Fuel Consumption Standards	13.1
EPA-Regulated Emissions Aftertreatment Systems	13.1
Diesel Exhaust Fluid and Tank	13.7

Emissions

Greenhouse Gas Emissions and Fuel Consumption Standards

Model year 2007 and later vehicles and/or engines domiciled in the U.S. or Canada are designed to meet Emission and Fuel Efficiency Standards of the U.S. (Federal) Environmental Protection Agency

(EPA), the National Highway Traffic Safety Administration (NHTSA), Emission Regulations under the Canada Motor Vehicle Safety Act in Canada, and the California Air Resources Board (CARB) effective as per the applicable emission model year. See [Table 13.1](#) and [Table 13.2](#) for EPA regulations. To determine an engine's or vehicle's emission model year, refer to the respective EPA/CARB certification label.

EPA Regulations	
Regulation	Emissions Components
EPA10 (Reduction of NOx emissions to 0.2 g/bhp-hr)	EPA07-type ATD, with additional selective catalyst reduction (SCR) technology that utilizes diesel exhaust fluid (DEF) to convert NOx to nitrogen and water vapor.
GHG21	GHG14/17 components plus additional components including, but not limited to, transmissions, axles, predictive technologies, idle reduction technologies for vocational vehicles, tire pressure monitoring systems.

Table 13.1, EPA Regulations

Emission Regulations by Model Year		
Model Year	Engine Regulation	GHG Regulation
2021–and later	EPA10, GHG21	GHG21

Table 13.2, Emission Regulations by Model Year

EPA-Regulated Emissions Aftertreatment Systems

NOTICE

Follow these guidelines for engines that comply with EPA07 or newer regulations, or damage may occur to the Aftertreatment System (ATS) and the warranty may be compromised.

- Use ultralow-sulfur diesel with 15 ppm sulfur content or less.
- Do not use fuel blended with used engine lube oil or kerosene.
- Engine lube oil must have a sulfated ash level less than 1.0 wt %; API CJ-4, CK-4, and FA-4 oils meet this requirement.

IMPORTANT: Using non-specification fuels or oils can lead to shortened diesel particulate filter (DPF) cleaning or replacement intervals. For example, using CI-4 Plus oil with 1.3% sulfated ash (30% more ash content) may result in the need for DPF cleaning or replacement 20 to 30% sooner than would normally be required.

IMPORTANT: See the engine manufacturer's operation manual for complete details and operation of the ATS.

Euro V Emission Compliant Engines for Export

IMPORTANT: Depending on local jurisdictional guidelines, vehicles that are domiciled outside of the U.S. and Canada may not have emissions aftertreatment systems (ATS) that are compliant with EPA regulations.

Vehicles sold with Euro V engines for export are required to use diesel with a maximum sulfur content as follows:

- Cummins Engines 50 ppm (tolerant to 500 ppm)
- Detroit Engines 50 ppm

See [Fig. 13.1](#) for an example of the label.

EPA10 and Newer Engines

The EPA mandates that all engines built after December 31, 2009 must reduce the level of



Fig. 13.1, Euro V Engine Label (Detroit engine label shown)

emissions exhausted by the engine to the following levels:

- Nitrogen Oxides (NOx) – 0.2 g/bhp-hr
- Particulate Matter (PM) – .01 g/bhp-hr

To meet EPA guidelines, engines that are compliant with EPA10 and newer regulations use an ATS where the exhaust first passes over the diesel oxidation catalyst (DOC), then passes through the diesel particulate filter (DPF), which traps soot particles. The soot is burned to ash during a process called regeneration (regen). A Selective Catalytic Reduction (SCR) device is used to reduce NOx downstream of the engine. After exhaust gases leave the DPF, a controlled quantity of diesel exhaust fluid (DEF) is injected into the exhaust stream. In the presence of heat, DEF is converted to ammonia gas, which reacts with NOx in the selective catalyst chamber to yield nitrogen and water vapor, which exit through the tailpipe.

Regeneration

The harder an engine works, the better it disposes of soot. If the exhaust temperature is high enough, a process called **passive regeneration** (regen) occurs as the vehicle is driven normally. However, if the engine isn't running hot enough, the electronic controls may initiate an **active regen**, whereby extra fuel is injected into the exhaust stream to superheat and reduce the soot trapped in the DPF to ash. Active regen happens only when the vehicle is moving above a certain speed, determined by the engine manufacturer. See your engine operation manual for complete details. Both active and passive regen happen automatically, without driver input.

⚠ WARNING

Active regeneration can occur automatically anytime the vehicle is moving. The exhaust gas temperature could reach 1500°F (800°C), which is hot enough to cause a fire, heat damage to objects or materials, or personal injury to persons near the exhaust outlet. The exhaust temperature can remain high even after the vehicle has stopped. When stopping the vehicle shortly after an automatic regen, ensure the exhaust outlets are directed away from structures, vegetation, flammable materials, and anything else that may be harmed by exposure to high heat.

See *Regen Operations*, below, for instructions on preventing automatic regen if necessary.

When operating conditions do not allow for ATD filter cleaning by active or passive regen, the vehicle may require a driver-activated **parked regen**. When this occurs, the driver display screen presents a message indicating that a regen is required. See [Fig. 13.2](#). The driver must either bring the vehicle up to highway speed to increase the load (thus starting an active regen), or park the vehicle and initiate a parked regen. See *Regen Operations*, below, for instructions on initiating a parked regen.

Regen Operations

Parked regen is initiated by selecting OK when the driver display screen shows 'Parked Regen Required.' See [Fig. 13.2](#). If the vehicle is equipped with the optional digital STOP REGEN switch, parked regen can be stopped by pressing OK on the screen while the regen is in progress. See [Fig. 13.2](#).

Some vehicles may be equipped with a REGEN OFF physical switch. See [Fig. 13.3](#). To stop a regen in progress or prevent the start of a regen, press the lower half of the switch. Regen is then delayed until the switch is no longer active.

NOTE: Parked regen can be initiated only when the DPF lamp is illuminated.

⚠ WARNING

During parked regen, exhaust temperatures are very high and could cause a fire, heat damage to objects or materials, or personal injury to persons near the exhaust outlet.

Emissions

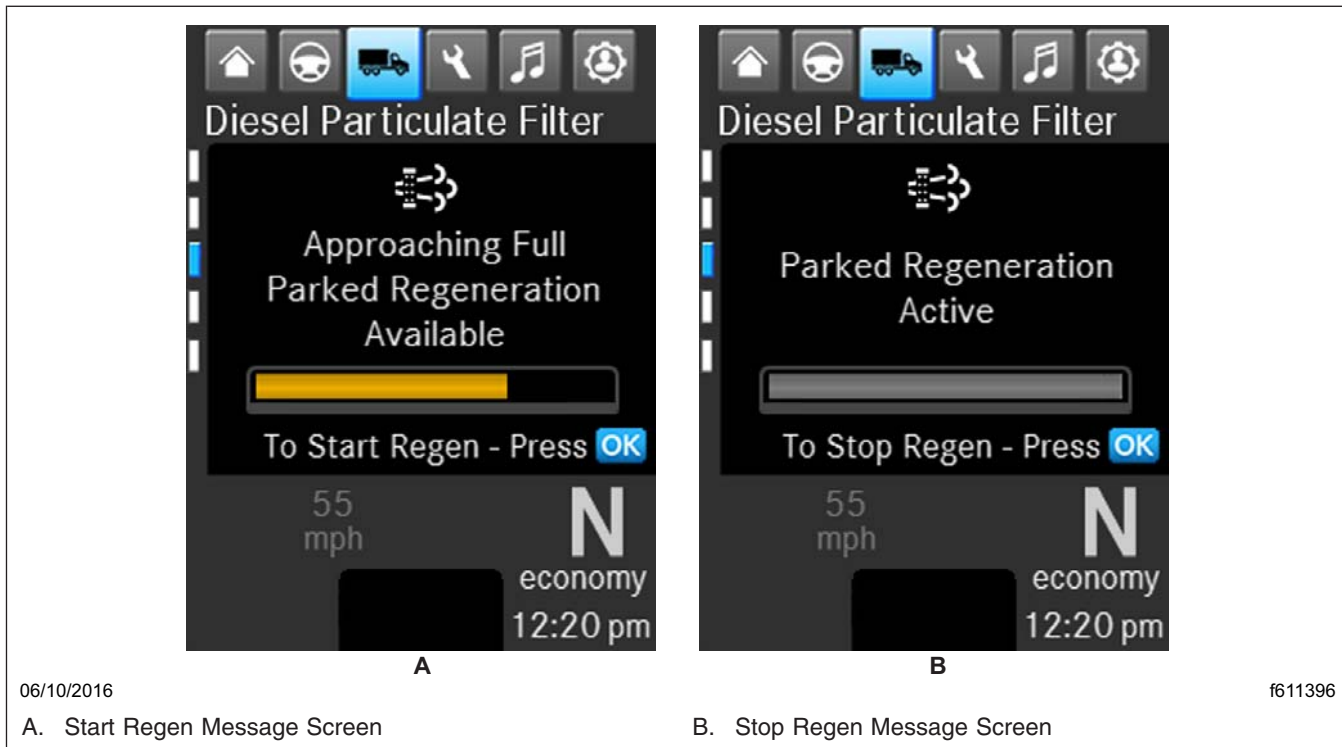

Fig. 13.2, Parked Regen Message Screens

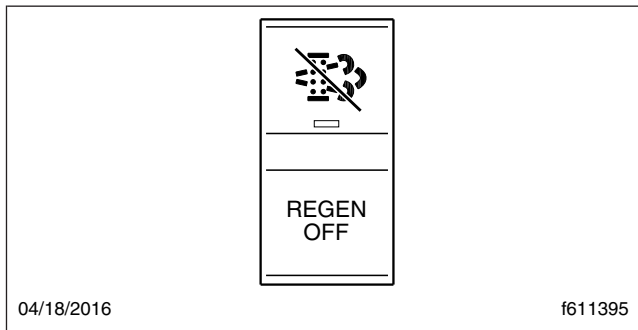

Fig. 13.3, Regen OFF Switch

Before initiating a parked regeneration, make certain the exhaust outlets are directed away from structures, vegetation, flammable materials, and anything else that may be harmed by prolonged exposure to high heat.

To initiate a parked regen, perform the following steps.

1. Park the vehicle away from all flammable materials, put the transmission in neutral, and set the parking brake.
2. Start and warm the engine until the coolant temperature is at least 150°F (66°C).

3. Select OK when the DPF screen is displayed on the driver display screen. See Fig. 13.2. Select OK again to confirm regen. As the regen process is initiated, engine rpm increases and the HEST lamp illuminates to indicate extremely high exhaust temperatures.

IMPORTANT: The driver is responsible for ensuring, during the entire regen cycle, that anything that could be harmed by exposure to high heat does not come in contact with the exhaust gases flowing from the outlets.

4. The regen cycle finishes after 20 to 60 minutes, at which time engine idle speed drops to normal and the vehicle can be driven normally. The HEST lamp is extinguished when vehicle speed exceeds 5 mph (8 km/h) or the system has cooled to normal operating temperature.
5. To stop a parked regen at any time during the process:
 - depress the clutch pedal, brake pedal, or accelerator pedal;
 - select OK on the parked regen screen while the regen is active, then select OK again to confirm;

- press and hold the regen inhibit switch until idle returns to normal;
- shut down the engine.

ATS Warning Lamps and Messages

There are three warning lamps that alert the driver of high exhaust temperature, the need to perform a parked regen or service the DPF, or of an engine fault that affects emissions. A decal attached to the driver's sun visor explains the ATS warning lamps.

Malfunction Indicator Lamp (MIL)

A steadily illuminated yellow malfunction indicator lamp (MIL) indicates an engine fault that affects emissions. See [Fig. 13.4](#).

DPF Status Lamp and Messages

When soot accumulates in the DPF, the driver display screen presents a DPF status bar. As the soot level in the DPF reaches 60 percent, the DPF

status lamp illuminates. See [Fig. 13.5](#). Perform a parked regen or bring the vehicle up to highway speed to increase the load (thus starting an active regen). After the soot level in the DPF reaches 80 percent, a parked regen is necessary.







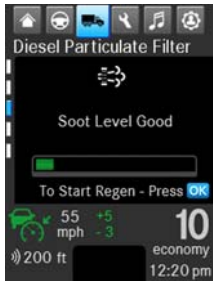
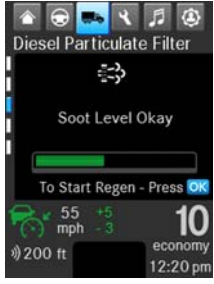



For an explanation of DPF zones, message screens, warning lamps, and available regen modes, see [Table 13.3](#) (Detroit engines) or [Table 13.4](#) (Cummins engines).

If the DPF status lamp blinks and the driver display screen shows a red status bar (90 percent full), initiate a parked regen immediately in order to prevent an engine derate.

If the DPF status lamp blinks, and the driver display screen shows a DPF status bar that is fully red (100 percent full), begin a parked regen in order to prevent an engine shutdown. Park the vehicle and perform a parked regen.



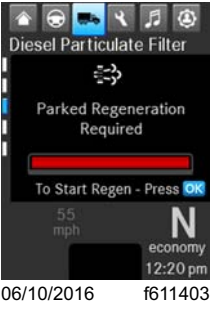



DPF Zones, Detroit Engines			
DPF Zone	DPF Status Bar	Warning Lamps	Regen Mode Available
0	 <p>06/10/2016 f611398</p> <p>0–10% Green</p>	—	<ul style="list-style-type: none"> • passive
1	 <p>06/10/2016 f611399</p> <p>10–60% Green</p>	—	<ul style="list-style-type: none"> • over-the-road

Emissions

DPF Zones, Detroit Engines			
DPF Zone	DPF Status Bar	Warning Lamps	Regen Mode Available
2	 <p>60–70% Yellow</p>	 <p>DPF solid yellow</p>  <p>HEST solid yellow*</p>	<ul style="list-style-type: none"> • over-the-road • parked
3	 <p>70–80% Yellow</p>	 <p>DPF flashing yellow</p>  <p>HEST solid yellow*</p>	<ul style="list-style-type: none"> • over-the-road • parked
4	 <p>80–90% Red</p>	 <p>DPF flashing yellow</p>  <p>HEST solid yellow*</p>	<ul style="list-style-type: none"> • parked
5	 <p>90–100% Red</p>	 <p>DPF flashing yellow</p>  <p>HEST solid yellow*</p>	<ul style="list-style-type: none"> • parked

* Illuminates if exhaust temperature is above a preset limit.

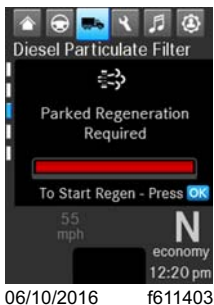
Table 13.3, DPF Zones, Detroit Engines

DPF Zones, Cummins Engines			
DPF Zone	DPF Status Bar	Warning Lamps	Regen Mode Available
1	 <p>0–60% Green</p>	—	<ul style="list-style-type: none"> • over-the-road
3	 <p>60–80% Yellow</p>	 DPF flashing yellow  HEST solid yellow*	<ul style="list-style-type: none"> • over-the-road • parked
5	 <p>80–100% Red</p>	 DPF flashing yellow  HEST solid yellow*	<ul style="list-style-type: none"> • parked

* Illuminates if exhaust temperature is above a preset limit.

Table 13.4, DPF Zones, Cummins Engines

High Exhaust System Temperature (HEST) Lamp

Slow (10-second) flashing of the high exhaust system temperature (HEST) lamp indicates that a parked regen is in progress, and the engine's high idle speed is being controlled by the engine software, not the vehicle driver.

Steady illumination of the HEST lamp alerts the driver of high exhaust temperature during the regen

process if the vehicle speed is below 5 mph (8 km/h), or during a parked regen. See [Fig. 13.6](#).

Maintenance

Authorized service facilities must perform any DPF service. For warranty purposes, maintain a record that includes:

- date of cleaning or replacement;
- vehicle mileage;

Emissions

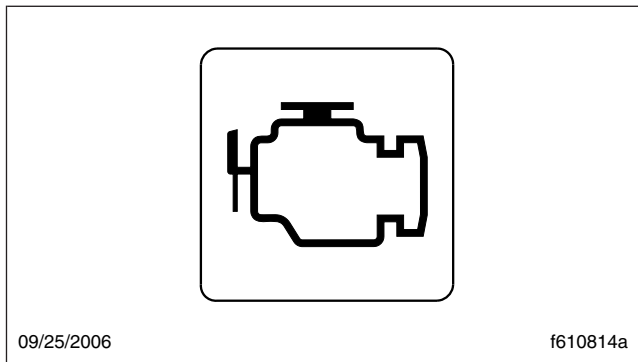

Fig. 13.4, Malfunction Indicator Lamp (MIL)

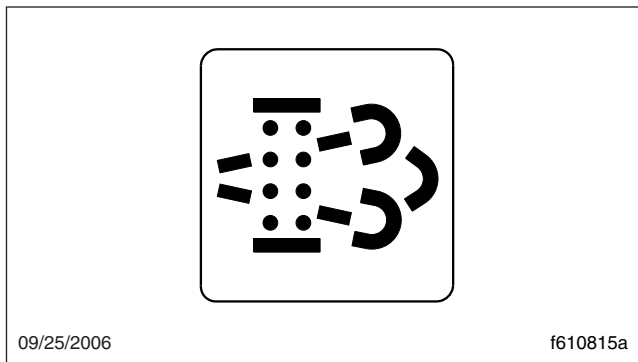

Fig. 13.5, DPF Status Lamp

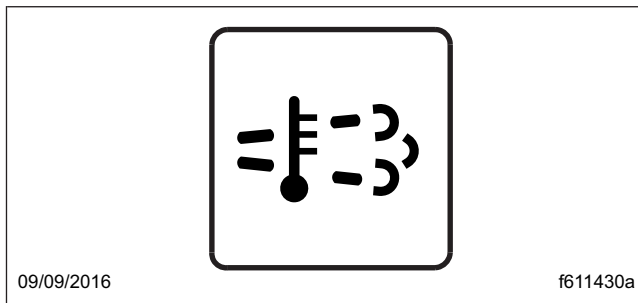

Fig. 13.6, HEST Lamp

- particulate filter part number and serial number.

Diesel Exhaust Fluid and Tank

Diesel Exhaust Fluid

Diesel exhaust fluid (DEF) is used in the ATS to lower NOx in the exhaust stream. DEF is colorless and close to odorless (it may have a slightly pungent odor similar to ammonia). It is nontoxic, nonflammable, and biodegradable. It is mildly corrosive to aluminum, but does not affect the strength or structure of the aluminum.

White crystals may be noticeable around components that come into contact with DEF. The crystals are easily removed with water.

DEF consumption varies depending on ambient conditions and vehicle application.

Freezing Conditions

DEF freezes to slush at around 12°F (-11°C). It is not damaged or destroyed if frozen, and is fully usable when thawed. The DEF in the tank is allowed to freeze while a vehicle is non-operational. At start-up, normal operation of the vehicle is not inhibited if the DEF is frozen; an immersion heater with engine coolant flowing through it warms the DEF once the engine is running, allowing the SCR system to operate.

DEF Tank

Engines that are compliant with EPA10 and newer regulations are equipped with a DEF tank located on the driver's side of the vehicle behind the battery box or forward of the fuel tank. The DEF tank has a 19 mm filler neck inlet that prevents the hose from a diesel outlet from being inserted, and has a blue cap for easy identification.

Fuel/DEF Gauge

The diesel fuel and DEF levels are measured in a dual-purpose gauge. Below the gauge, a low fuel warning lamp illuminates amber when the fuel level drops below 1/8th of the capacity. See [Fig. 13.7](#).

A DEF warning lamp illuminates amber when the DEF tank is near empty.

DEF Warnings and Engine Limits

IMPORTANT: Ignoring the DEF low level warnings results in limited engine power, with the application of a 5 mph (8 km/h) speed limit.

DEF Level Low—Initial Warning

When the DEF level is low, the DEF warning lamp illuminates solid amber, and the driver display screen presents an alert. See [Fig. 13.8](#). Refill the DEF tank in order to cancel the warning sequence.

DEF Empty

When the DEF level reads empty, the following lamps and messages notify the driver.

- The DEF warning lamp flashes amber.

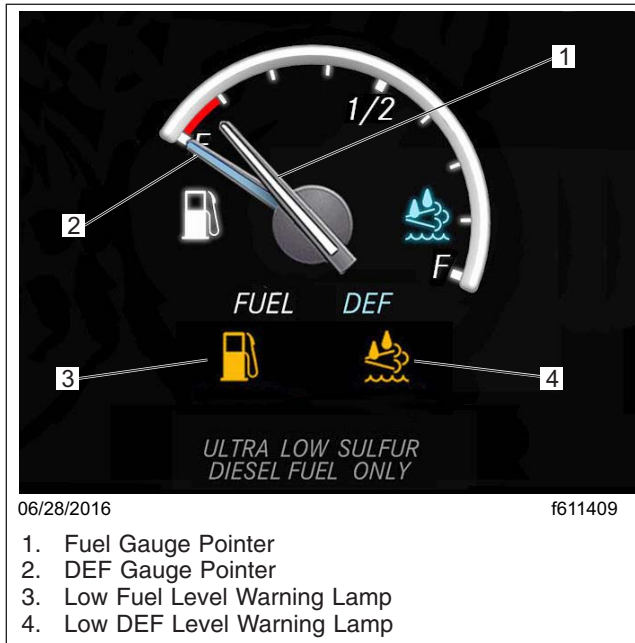

Fig. 13.7, Fuel/DEF Gauge

DEF Tank Empty and Ignored

If the empty warning is ignored and the DEF tank is not refilled, the red STOP engine lamp illuminates in addition to the MIL lamp and CHECK engine lamp (on vehicles with a Cummins ISB or ISC/L engine).

If the DEF is not refilled, a 5 mph (8 km/h) speed limit is applied after the next engine shutdown, while parked and idling, or if a fuel refill is detected.

DEF Contamination or SCR Tampering

NOTICE

Once contaminated DEF or tampering has been detected, the vehicle must be taken to an authorized service facility to check the SCR system for damage and to deactivate the warning lights and engine limits.

If contaminated DEF or tampering with the ATS is detected, the DEF warning light flashes and the MIL lamp illuminates to warn the driver. The CHECK

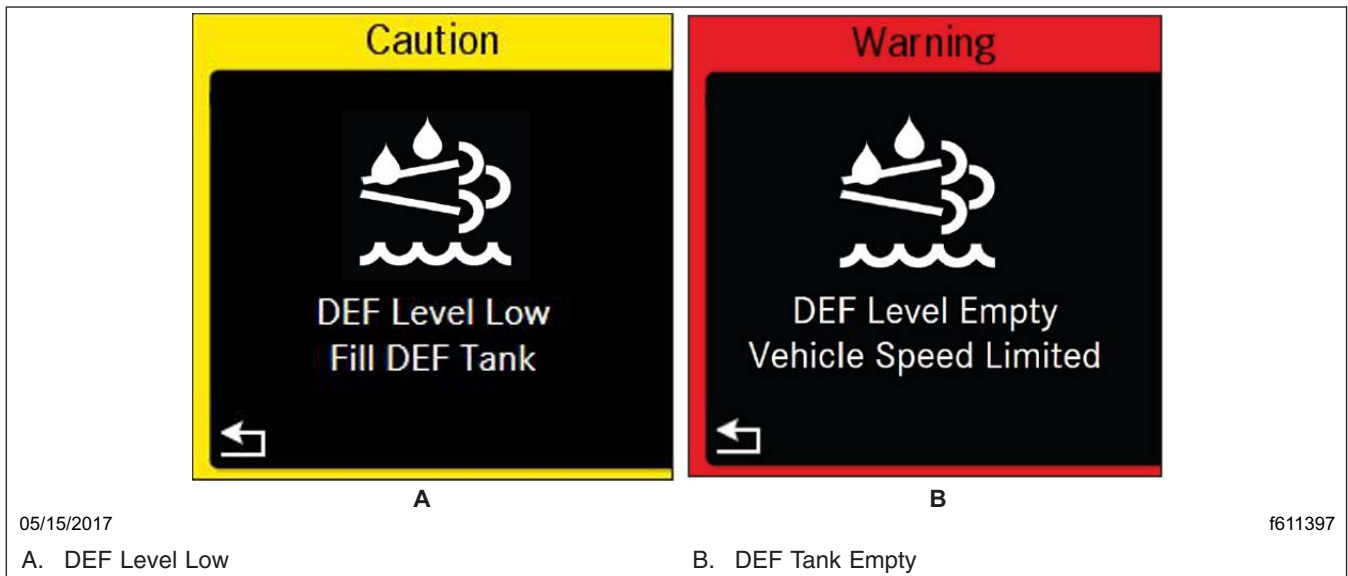

Fig. 13.8, DEF Level Messages

- The MIL lamp illuminates.
- The driver display screen presents the warning, 'DEF Tank Empty.' See [Fig. 13.8](#).

Power is limited with progressively harsher engine power limits applied.

engine lamp also illuminates on vehicles with a Cummins ISB or ISC/L engine.

- Detroit engines: Engine power is limited with progressively harsher limits applied. If the fault is not corrected, the STOP engine light illuminates and a 5 mph (8 km/h) speed limit is applied after the next engine shutdown, while parked and idling, or if a fuel refill is detected.

Emissions

- Cummins engines: Engine power is limited with progressively harsher limits applied. If the fault is not corrected, the STOP engine light illuminates and a 5 mph (8 km/h) speed limit is applied after the next engine shutdown, or while parked and idling.

Automated and Automatic Transmissions

Automated/Automatic Transmission Shift Control	14.1
Detroit™ Automated Transmissions (DT12)	14.3
Eaton™ Automated Transmissions	14.8
Allison Automatic Transmissions	14.13
Allison On-Highway Transmissions	14.15
Allison Transmission® MD Series	14.18

Automated and Automatic Transmissions

Automated/Automatic Transmission Shift Control

Vehicles with automated or automatic transmissions use the multifunction stalk switch control shown in Fig. 14.1 and Fig. 14.2. This control can be used to request manual shifts, change driving mode, and set engine brake levels. See Table 14.1 for an overview of control functionality.

Direction Switch

Use the direction switch to request drive (D), neutral (N), or reverse (R). See Fig. 14.1, Ref. A.

Mode Switch

The driving mode can be changed using the Mode switch on the shift control. See Fig. 14.1, Ref. B and C.

Gear Switch

For automated and automatic transmissions, gear shifts can be requested manually; push the lever away to request a downshift, or pull the lever toward you to request an upshift, shown in Fig. 14.1, Ref. D and E. See Table 14.1 for more information about upshift and downshift requests.

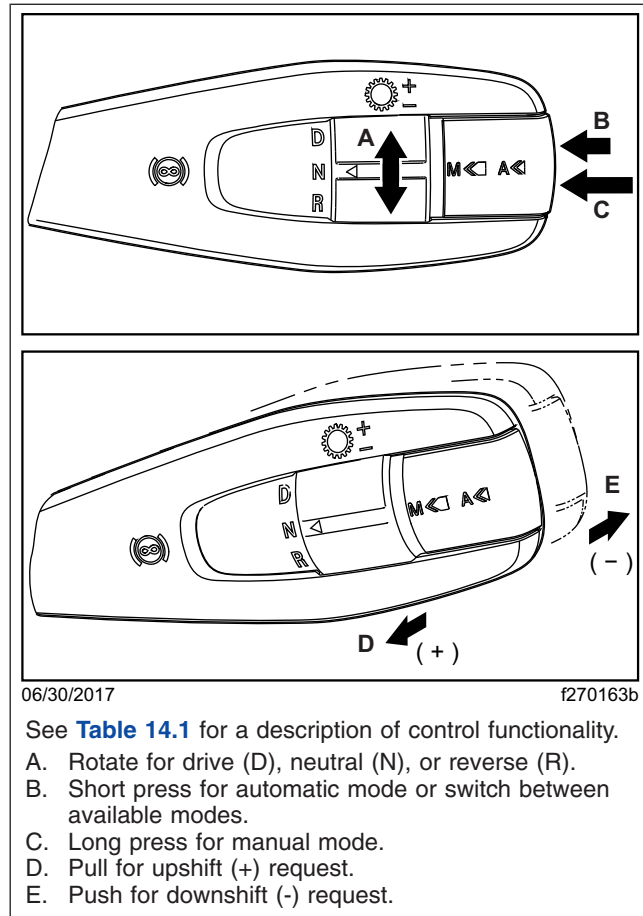

06/30/2017

f270163b

See Table 14.1 for a description of control functionality.

- A. Rotate for drive (D), neutral (N), or reverse (R).
- B. Short press for automatic mode or switch between available modes.
- C. Long press for manual mode.
- D. Pull for upshift (+) request.
- E. Push for downshift (-) request.

Fig. 14.1, Automated/Automatic Transmission Shift Control

Functionality, Automated/Automatic Transmission Shift Control		
Function/Switch	Action/Position	Request
Direction	All Transmissions	
	D	Forward gears
	N	Neutral
Mode	Short press	Detroit and Eaton: Activate the automatic drive mode, or switch between available modes Allison: Switch between available shift modes.
	Long press	Detroit and Eaton: Activate the manual drive mode (if available) Allison: Switch between automatic and manual drive mode.

Automated and Automatic Transmissions

Functionality, Automated/Automatic Transmission Shift Control		
Function/Switch	Action/Position	Request
Gear (Detroit Automated Transmissions)	Detroit Automated Transmissions	
	Short pull on the lever	Upshift, single gear
	Pull on the lever in quick repetitions	Upshift, multiple gears
	Short push on the lever	Downshift, single gear
	Push on the lever in quick repetitions	Downshift, multiple gears
Gear (Eaton Automated Transmissions)	Eaton Automated Transmissions	
	Short pull on the lever	Upshift, single gear
	Pull on the lever in quick repetitions	Upshift, multiple gears
	Short push on the lever	Downshift, single gear
	Push on the lever in quick repetitions	Downshift, multiple gears
	While in automatic drive mode, long push on the lever	Downshift to low mode
	While in low mode, pull on the lever	Exits low mode and returns to automatic drive mode
	While in reverse mode, push on the lever	Selects deep reverse gear
While in deep reverse gear, pull on the lever	Upshifts to standard reverse gear	
Gear (Allison Automatic Transmissions)	Allison Automatic Transmissions	
	Short pull on the lever	Upshift, single gear
	Pull on the lever in quick repetitions	Upshift, multiple gears
	Short push on the lever	Downshift, single gear
	Push on the lever in quick repetitions	Downshift, multiple gears
	While in automatic drive mode, long push on the lever	Downshift to low mode
	While in low mode, pull on the lever	Exits low mode and returns to automatic drive mode
	While in reverse mode, push on the lever	Selects deep reverse gear (only on 7-speed 4000 Series transmissions)
While in deep reverse gear (only on 7-speed 4000 Series transmissions), pull on the lever	Upshifts to standard reverse gear	
Engine Brake *	Engine Brake Functions	
	Lever at position 0 (top)	Engine brake off
	Lever at position 1	Low intensity
	Lever at position 2	Medium intensity
	Lever at position 3 (bottom)	High intensity

* For functions with cruise control active, see [Chapter 7](#).

Table 14.1, Functionality, Automated/Automatic Transmission Shift Control

Engine Brake

The engine brake is controlled by the lever position (as shown in [Fig. 14.2](#)). At the top position, the engine brake is off, and at the three lower positions, the engine brake is on and the intensity (low, medium, high) increases with each step down.

NOTE: Using the engine brake with cruise control can be used to activate Descent Control Mode or Deceleration Mode. For more information, see "Cruise Control" in [Chapter 7](#).

Power Up and Shift into Gear

1. With the parking brake set and Neutral (N) selected on the shift control, turn the ignition switch to the ON position.
2. Start the engine.
3. Apply the service brake.
4. Select the desired starting gear.
5. Release the parking brake.
6. Release the service brake and apply the accelerator.

Automated and Automatic Transmissions

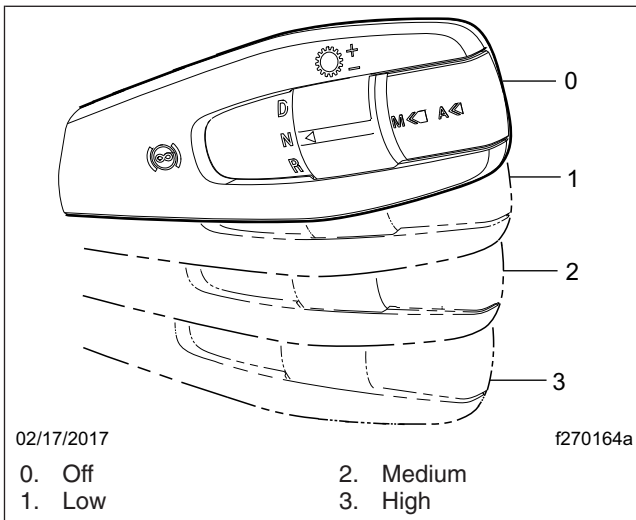

Fig. 14.2, Engine Brake Positions

Gear Display

The current transmission gear and driving mode are displayed in the static menu at the bottom of the driver display screen. See Fig. 14.3.

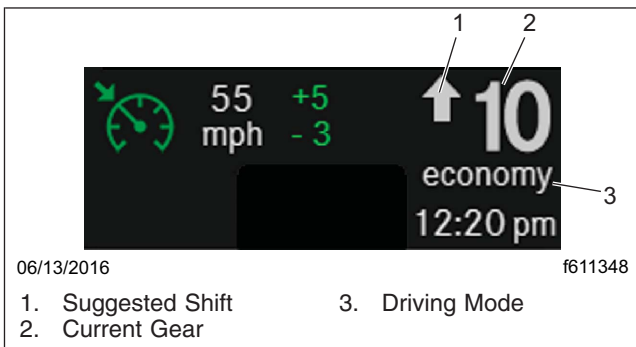

Fig. 14.3, Typical Gear Display (Detroit and Eaton)

Selected Gear (Detroit and Eaton Transmissions)

If the selected gear is different than the current gear for longer than a half second, the current gear display will flash and the selected gear value will be shown. Once the current gear and selected gear match, the selected gear display disappears and the current gear display stops flashing.

Suggested Shift (Detroit and Eaton Transmissions)

In Manual mode only (if available), a suggested shift is displayed to indicate the most economical gear available. The suggested shift is the number of up or down arrows from the current gear with a maximum of three up or down arrows.

Detroit™ Automated Transmissions (DT12)

Detroit transmissions have twelve forward gears and up to four reverse gears that can be shifted automatically or manually. Shifting and clutch actuation are computer controlled, and there is no clutch pedal needed to operate the vehicle.

Automatic shifts are selected for fuel economy or engine power. Manual shifts can be requested with the shift control and the transmission ECU grants them when conditions permit. In all cases, shifts depend on the following factors: engine speed, accelerator pedal position, service brake usage, engine brake operation, vehicle load status, and road conditions.

NOTE: To avoid potential engine stall risk or unexpected shifting, use the interaxle differential lock when the vehicle is operated in slippery conditions. See Chapter 19 for information about the interaxle differential lock.

Driving Modes

There are three driving modes: Manual, Automatic Economy, and Automatic Performance. To activate the manual drive mode, press and hold the mode switch briefly. Press the switch quickly to activate the automatic drive mode or change between modes. See Fig. 14.1.

In Automatic Economy mode, gear shifts are designed for saving fuel. In Automatic Performance mode, gear shifts are designed for higher performance and are made at higher engine speeds. In manual mode, gear shifts are requested manually.

NOTE: In Automatic Performance mode, the transmission will automatically change to Automatic Economy mode if it hasn't received a request for more power in several minutes, unless current road conditions require higher engine performance.

Automated and Automatic Transmissions

eCoast

The eCoast feature can improve driving economy. When conditions permit, the transmission control automatically shifts the transmission to neutral to coast at speeds of approximately 50 mph (80 km/h) and above. However, the vehicle can coast down to 45 mph (72 km/h). An "E" shows in the gear display when eCoast is in effect. See [Fig. 14.4](#).



Fig. 14.4, eCoast Display

To turn eCoast on or off, navigate to the transmission settings screen. See [Fig. 14.5](#).

The eCoast function is not active when any of the following occur:

- the accelerator pedal is pressed.
- vehicle acceleration rate is exceeded.
- the service brake pedal is pressed.
- the engine brake is in use.
- cruise control brakes or accelerates.
- vehicle speed exceeds the cruise control set speed by more than approximately 4 mph (6 km/h).
- the speed limiter is active and the maximum speed set is exceeded.
- diesel particulate filter (DPF) regeneration occurs.

NOTE: eCoast availability and the On/Off screen are customer-selectable parameters. To enable or disable eCoast, see an authorized Freightliner service facility.

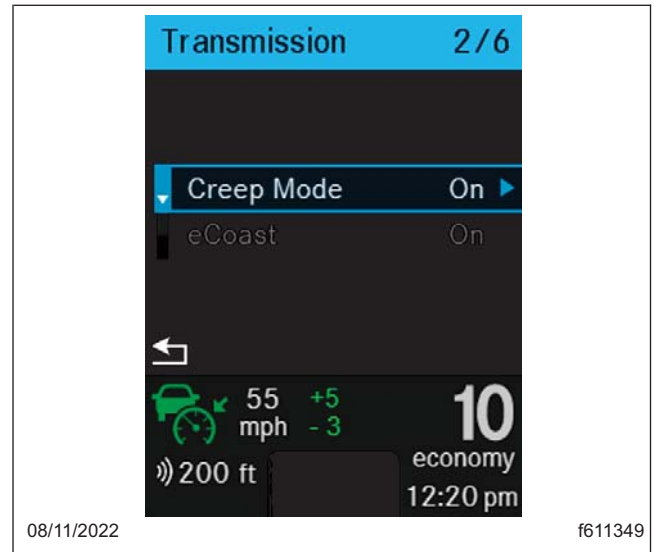

Fig. 14.5, eCoast and Creep Mode On/Off Screen

Creep Mode

Creep mode allows the vehicle to be maneuvered at very slow speeds. To activate Creep mode for the first time within the current driving cycle, press the accelerator pedal to launch the vehicle, thereby modulating the clutch and allowing it to slip. Following this and for the duration of the current driving cycle, Creep mode is active.

Once the vehicle is stopped via the service brakes, the vehicle will begin to creep again, without the accelerator pedal actuation, as soon as the service brakes are released.

To begin using Creep mode (once active) from a parked position, shift from neutral to either drive or reverse, release the service brakes, and briefly depress the accelerator pedal. The vehicle's urge to move can then be felt.

If creep is active and no acceleration is achieved, then Creep mode will abort. A display message notifies the operator when Creep mode is about to be aborted.

IMPORTANT: When slowing down from higher speeds in drive or reverse, remember that Creep mode will be in effect at lower speeds. Use the service brakes to stop the vehicle.

Automated and Automatic Transmissions

To turn Creep Mode on or off, navigate to the transmission settings screen (if available). See [Fig. 14.5](#).

NOTE: Creep mode availability and the On/Off screen are customer-selectable parameters. To enable or disable creep mode, see an authorized Freightliner service facility.

Hill Start Aid (HSA)

Detroit transmissions are equipped with a Hill Start Aid (HSA) feature to prevent rolling backward when launching the vehicle on an uphill grade. The system delays the release of service brakes until enough torque is available to begin moving the vehicle forward. The system will hold the brakes for a maximum of 3 seconds. If driveline torque is not detected, the system will audibly alert the driver and release the brakes.

Clutch Abuse Protection

A vehicle equipped with a Detroit transmission does not have a clutch pedal, but still has a clutch that is operated automatically and can be damaged by abusive driver actions. To protect the clutch, the vehicle has a clutch abuse protection system that alerts the driver and restricts functionality when needed. Extended periods in Creep Mode, slipping the clutch (using the accelerator pedal to hold the vehicle on a hill, for example), and high clutch temperatures can activate the clutch abuse protection system. A display message notifies the operator when the protections are needed.

NOTICE

To hold the vehicle stationary on an uphill slope, use the service brakes, not the accelerator pedal. Using the accelerator pedal can overheat and damage the clutch. To start moving, use the accelerator pedal and release the brakes as the vehicle begins to move.

There are three clutch abuse protection levels. At each, the driver is alerted and functionality is modified; see [Table 14.2](#).

To avoid clutch overheating, follow these tips:

- To hold the vehicle stationary on an uphill slope, use the service brakes, not the accelerator pedal.

- To start moving on an uphill slope, use the accelerator pedal and release the brakes as the vehicle begins to move.
- When hooking up to a trailer, ensure the trailer is high enough to back under, and use first gear reverse.
- Avoid starting in higher gears, and start in first gear when a trailer is attached.
- Ensure trailer brakes have had time to completely release prior to starting.
- Do not use Creep mode for an extended period. Stop or adjust the vehicle speed when warned to deactivate Creep mode.

Engine Overspeed Alerts

To help protect the engine, the system has display messages to notify the operator when the engine has exceeded certain thresholds and needs to be slowed down before significant engine damage occurs. There are two warnings, one at about 2300 rpm and another at 2500 rpm, indicated with messages and a fault code.

Descent Control Mode

Descent Control mode helps control the vehicle and engine speed when descending a grade.

NOTE: Before engaging Descent Control mode, determine an appropriate speed for the vehicle load and grade of the road.

To activate Descent Control mode, manually set the engine brakes with the shifter stalk and, while the engine brakes are actively working, set cruise to the desired descent speed. A Descent Control mode engaged icon will appear on the ICUC screen showing it is active. See [Fig. 14.6](#)

The Descent Control mode will attempt to manage the vehicle's speed by varying the engine brake level.

The driver should be ready to intervene by applying the service brakes if the grade is too steep and the vehicle is traveling too fast. Applying the service brake to slow the vehicle will not cancel cruise control. Once the service brake is released, the vehicle speed becomes the new Descent Control set speed. A pop-up will appear on the instrument cluster screen to notify the driver of the new speed. See [Fig. 14.7](#).

Automated and Automatic Transmissions



Fig. 14.6, Descent Control Mode Active

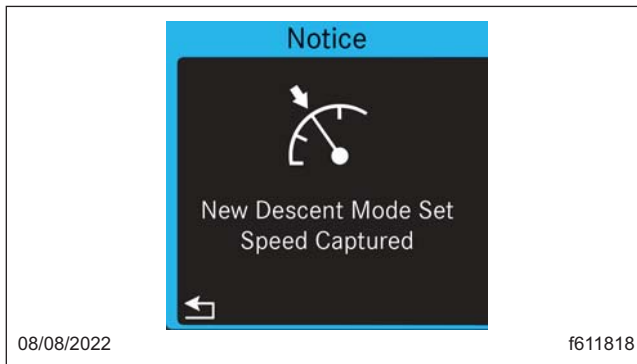

Fig. 14.7, New Descent Control Mode Set Speed Pop-Up

When the vehicle's descent is complete, return the engine brake stalk to the OFF/Auto position. At this point the Descent Control set speed will become the new cruise speed.

Hill Descent Upshift Feature

NOTE: It is critical that the driver maintains complete control over the vehicle at all times.

The proper speed, and gear if in manual mode, should be selected before the crest of any hill to ensure a safe descent. The driver should apply engine and service brakes appropriately during any descent.

The Detroit™ Automated Transmission (DT12) is capable of upshifting automatically when descending grades. When the vehicle is descending without engine or service brake application, the DT12 will upshift at 2000 rpm. If the engine or service brake is applied during descent, the DT12 will upshift at 2400 rpm.

Transmission Low Air Warning



If the yellow "Caution: Transmission Air Supply Low" popup appears while the vehicle is in operation, slow down, safely pull the vehicle off the road, then correct the problem.

Pneumatic controls are used to shift the transmission. If there is inadequate air pressure, a yellow caution pop-up will appear and the quality of gear shifts may be degraded. See [Fig. 14.8](#). Wait for air pressure to build before operating the vehicle.



Fig. 14.8, Low Transmission Air Pressure Pop-up



If the red "Warning: Transmission Will Not Shift" popup appears while the vehicle is in operation, choose the safest location available to pull the vehicle off the road. Prepare for the vehicle to be immobile if the problem cannot be resolved.

If a severe loss of air pressure occurs, a red warning pop-up will appear and the transmission will not shift. See [Fig. 14.9](#).

Clutch Abuse Alerts and Protections

Automated and Automatic Transmissions



Fig. 14.9, No Transmission Air Pressure Pop-up

Clutch Abuse Alerts and Protections				
Alert Level	Alert	Protections		
		Highest Start Gear	Creep Mode	Clutch Function
1	Heavy clutch load message	1	No restriction	Normal function
2	Heavy clutch load message	1	Disabled	Normal function
3	Clutch overload message and buzzer	1	Disabled	If the accelerator pedal is depressed, the clutch closes at fixed rate. If the accelerator pedal is released, the clutch opens at fixed rate.

Table 14.2, Clutch Abuse Alerts and Protections

Auto Neutral



Do not leave the driver's seat without placing the shift stalk lever in the neutral position and applying the parking brake. Failure to do so could cause property damage and personal injury.

The auto neutral feature shifts the Detroit transmission into neutral if the drive direction switch is left in drive or reverse for an extended period of time. The driver is warned of a pending shift with a flashing N in the gear position display of the instrument cluster. A brief warning buzzer activates when the transmission shifts into neutral. See [Table 14.3](#) for all the conditions and indicators that are possible.

Note: If the auto neutral feature is activated, apply the service brake and cycle the gear

direction switch to neutral, and back to the desired position.

Additionally for vehicles equipped with CPC3Evo, if the engine is shutdown without the drive direction switch in the N position, the warning buzzer activates for a long period of time, and a pop-up appears on the driver display screen, prompting the driver to place the shifter into the neutral position.



If the transmission doesn't achieve neutral before shutdown, it will not restart until it can complete the shift to neutral.

If neutral gear is not achieved, a pop-up message appears on the driver display screen, encouraging the driver to start the engine and allow the transmission to achieve neutral gear.

Automated and Automatic Transmissions

Direction Switch D or R				
CPC model	All		CPC4	CPC3Evo
Key Position	ON with Engine Idling		Ignition OFF	Ignition OFF
Brake Position	Parking brake ON	Parking brake OFF	Parking brake ON or OFF	Parking brake ON or OFF
Gear Display	Flashing N (short duration)	Flashing N (long duration)	—	Shift into neutral
Warning Buzzer	Short duration activation	Short duration activation	—	Long duration activation
Gear Position	Neutral, when the buzzer sounds	Neutral, when the buzzer sounds	In gear or neutral	In gear or neutral

Table 14.3, Direction Switch D or R

Eaton™ Automated Transmissions

Eaton automated transmissions use a multi-function stalk switch, shown in Fig. 14.1, or a push-button shift selector to select mode, direction, neutral, low, and to make manual shifts. To know what gear the transmission is in, see the driver display. Forward shifts can be made either manually or automatically.

Multi-Function Stalk Switch

Automatic Mode (A)

In automatic drive mode, upshifts and downshifts are made by the transmission without driver intervention.

Use the mode switch on the shift control to select the automatic mode (A). Rotate the D/N/R switch to Drive (D), and press down on the throttle pedal. The transmission will shift automatically.

NOTE: If attempting to select a non-Neutral mode without applying the service brakes, the transmission will not shift into gear. To shift into gear, select Neutral, apply the service brakes, and select the desired mode again.

In Drive, the start gear is automatically selected. The selected start gear can vary depending on several vehicle inputs such as load, grade, and axle/transmission ratio. The start gear can be changed using the shift control, provided the selected gear would allow the vehicle to launch without damaging the transmission. If the start gear is changed using the shift control, it will be the default until the vehicle is powered down or the selection is changed again manually.

IMPORTANT: Prior to ascending a steep grade, either reduce the default start gear by one

(using the shift control) or apply full throttle for the duration of the grade so the vehicle maintains the proper engine and vehicle speed during the entire grade.

In Drive, the transmission automatically performs upshifts and downshifts. However, when the transmission is near the shift point, the shift can be forced using the upshift or downshift function of the shift control.

NOTE: The transmission may deny a shift while ascending or descending a grade if the load of the vehicle and grade of the terrain in combination with the drivetrain ratio and engine torque fall outside of the acceptable range to perform a shift. If the shift is denied, a tone will sound.

Manual Mode (M)

In manual mode, the driver requests upshifts and downshifts instead of letting the Eaton transmission select them automatically. Manual shifting may be helpful when traversing a work site, railroad tracks, or steep grades, for example.

Use the mode switch on the shift control to select the manual mode (M). To drive forward, rotate the D/N/R switch to Drive (D), and press down on the throttle pedal. To shift up, pull the lever up (towards you); to shift down, push the lever down (away from you). The system holds the current gear unless a shift is requested or if the system initiates a manual mode override.

NOTE: The transmission may deny a shift while ascending or descending a grade if the load of the vehicle and grade of the terrain in combination with the drivetrain ratio and engine

Automated and Automatic Transmissions

torque fall outside of the acceptable range to perform a shift. If the shift is denied, a tone will sound.

NOTE: If attempting to select a non-Neutral mode without applying the service brakes, the transmission will not shift into gear. To shift into gear, select Neutral, apply the service brakes, and select the desired mode again.

Manual Mode Override

The system is equipped with a manual mode override function. If the vehicle is being "back driven" (for example, descending a grade and the engine speed is excessively high), the system will upshift automatically. Also, if the start gear is changed and it causes the engine to lug at takeoff, the system will override the current position and select the best available gear.

Low (L)

Use Low when wanting to maximize engine braking and minimize the use of the brake pedal—for example, when driving down long grades or when coming to a stop. To select Low, push down on the multi-function stalk switch, and hold in the down-shift position for half a second or more. The lowest available start gear will be selected (the starting gear cannot be changed in Low).

If Low is selected while moving, the transmission will not upshift (unless the system initiates a Low override). The system will downshift at the earliest opportunity to provide maximum engine braking.

NOTE: If attempting to select a non-Neutral mode without applying the service brakes, the transmission will not shift into gear. To shift into gear, select Neutral, apply the service brakes, and select the desired mode again.

Low Override

The system is equipped with a Low override function. If the vehicle is being "back driven" (for example, descending a grade and the engine speed is excessively high), the system will upshift automatically. Also, if the start gear is changed and it causes the engine to lug at takeoff, the system will override the current position and downshift.

Push-Button Shift Selector

Gear information is presented to the driver on the push-button shift selector, shown in [Fig. 14.10](#),

usually mounted on the right-hand control panel. On this display, the information is presented as follows:

- To select neutral, press the N button. When neutral is engaged, the telltale LED will light up next to the N button.
- To select reverse, press the R button. When reverse is engaged, the telltale LED will light up next to the R button.
- To select drive, press the D button. When drive is engaged, the telltale LED will light up next to the D button.
- To select low gear, press the LOW button. When low is engaged, the telltale LED will light up next to the LOW button.
- To change gears manually, press the MANUAL button. When the manual mode is engaged, the telltale LED will light up next to the MANUAL button.
- Use the shift buttons (upshift/downshift) to change the current starting gear selection in R, D, and LOW. In MANUAL, the shift buttons can be used to select gears.
- In automatic mode, the number of the forward gear currently engaged appears continually on the mode indicator when in drive. In MANUAL, the last gear selected appears on the mode indicator.
- If the SERVICE indicator illuminates, take the vehicle as soon as possible to an authorized Freightliner service facility.
- The mode button is reserved for future use.

IMPORTANT: To prevent engine overspeed, the transmission software will override both MANUAL and LOW if necessary. The system will not respond to gear selection requests that will either overspeed or excessively lug the engine.

Automatic Mode

When the transmission is in automatic mode, the transmission automatically selects and engages the gears, although the transmission will respond to upshift and downshift requests as though in manual mode. See the instructions for shifting under heading 'Manual Mode' below.

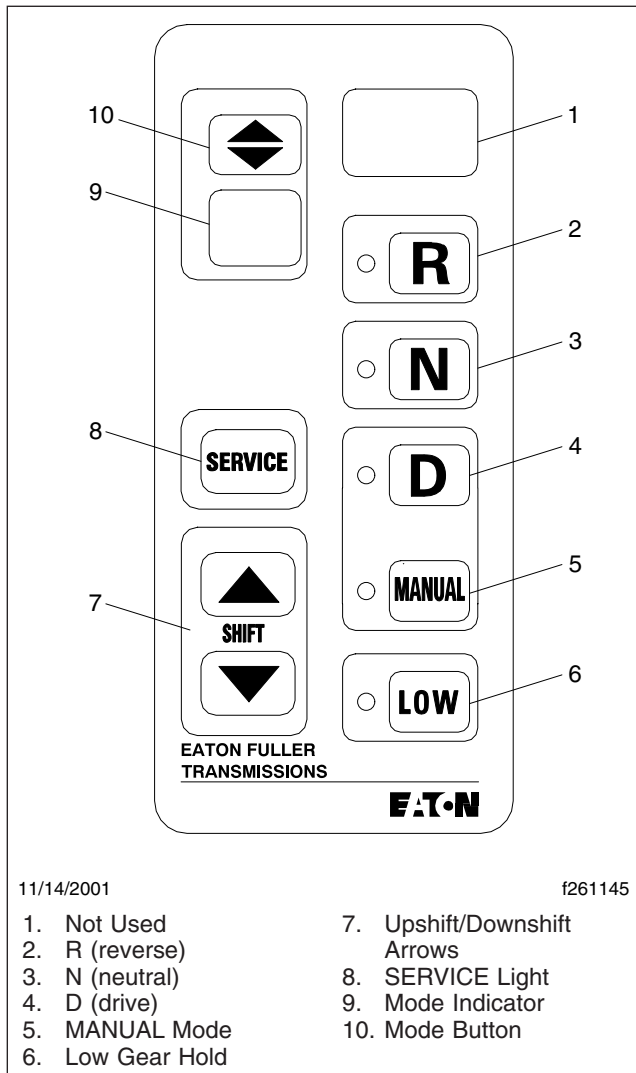

Fig. 14.10, Eaton Push-Button Shift Selector

Manual Mode

To select MANUAL mode, press the MANUAL button on the push-button shift selector. When the transmission is in manual mode, the driver must select the appropriate gear, using the shift buttons on the push-button shift selector.

To upshift in MANUAL, press the upshift button (up arrow), and release. The number of the gear will appear on the mode indicator. If the requested gear is available, the transmission will shift up.

NOTICE

Do not attempt to upshift until the vehicle has reached a sufficient speed. The clutch absorbs the speed difference by generating heat, which causes the clutch to wear out too soon.

Many drivers upshift into the next gear or even skip-shift into a higher gear before the vehicle has reached the correct speed. This type of shifting is almost as bad as starting off in a gear that is too high. When the engine speed (rpm) and the vehicle speed (mph or km/h) are too far apart, the clutch must absorb the difference in speed by generating heat.

To downshift in MANUAL, press the downshift button (down arrow), and release. The number of the gear will appear on the mode indicator. If the requested gear is available, the transmission will shift down.

If any requested gear is not available, an audible warning will sound and the digital display will indicate that the gear is not available.

Selecting Gears

R (Reverse)

Reverse (R) is used to back the vehicle. Make sure the vehicle comes to a full stop and the clutch pedal has been pressed before shifting into reverse.

To select reverse, press the clutch pedal to the floor. Then press the R button.

N (Neutral)

Neutral (N) is used for starting, parking, or any stationary operation. No gear is selected. The transmission must be in neutral to start the engine.

IMPORTANT: If the vehicle starts up in any gear but neutral, bring the vehicle to an authorized Freightliner service facility as soon as possible.

To select neutral, press the clutch pedal to the floor. Then press the N button. Set the parking brakes and slowly release the clutch pedal.

NOTE: Neutral is always available during vehicle operation. When in neutral, requests to upshift or to downshift are ignored.

D (Drive)

Drive (D) is used for normal highway driving. In drive, the transmission shifts into the proper gear for starting, and then automatically selects additional

Automated and Automatic Transmissions

gears as needed, in a range between the starting gear and the highest gear.

To select drive, press the clutch pedal to the floor. Then press the D button. Slowly release the clutch pedal and drive the vehicle.

To start up in a gear other than the normal starting gear, push the upshift arrow with D selected, and while the vehicle is stopped.

IMPORTANT: AutoShift will not start up in any gear higher than third gear.

The number of the gear selected will flash on the auxiliary display until the driver presses the clutch pedal. This gear will be stored in memory as the default starting gear until a different starting gear is selected by the driver, or until the engine is shut down.

NOTE: The transmission may be programmed so that it is not possible to select a starting gear other than the preprogrammed starting gear.

L (Low)

LOW is used to hold the transmission in low gear when descending steep hills. If LOW is selected when the vehicle is stopped, the transmission remains in low gear until drive is selected. If LOW is selected while the vehicle is moving, the transmission downshifts at a higher engine speed than normal, in order to maximize the engine braking effect.

To select LOW, press the clutch pedal to the floor. Then press the LOW button. Slowly release the clutch pedal and drive the vehicle.

IMPORTANT: Before parking the vehicle, always do the following:

- Place the transmission in neutral.
- Set the parking brakes.
- Chock the tires, if parking on an incline.

Clutch Abuse Protection

Although a vehicle equipped with an Eaton automated transmission uses an automated clutch, the clutch can still overheat and slip with improper use. The clutch abuse protection feature helps protect the clutch if the automated clutch starts to overheat. When the clutch abuse protection feature initiates and sounds a warning tone, full clutch actuation must be completed quickly. If it is not

completed quickly enough, the system will either open the clutch (if the throttle pedal is not being pressed) or close the clutch (if the throttle pedal is being pressed). If the abuse continues, the system will open the clutch and take away throttle control briefly to allow the clutch to cool down.

To protect the clutch:

- Select the lowest possible start gear for the application.
- Use Creep Mode when appropriate.
- Use the service brakes and the Hill Start Aid when launching on a grade.
- Minimize the time it takes to engage the clutch from rest.
- Do not use the throttle to hold the vehicle on a grade; use the service brakes.
- Do not use the throttle to stop roll back on an incline after Hill Start Aid disengages; use the service brakes, and then relaunch.
- Do not continually start and stop, especially when loaded; use a lower gear or Creep Mode.

Creep Mode

The Creep Mode function allows the vehicle to maintain a constant speed at engine idle without the driver holding the throttle pedal position. This mode is useful for very low-speed maneuvering and applications where steady vehicle speed is required. The vehicle speed is determined by the selected gear ratio operating at governed low engine idle speed. Any available gear may be selected, though the transmission will downshift or exit Creep Mode to prevent stalling if the engine lugs due to load conditions.

By default, Creep Mode can be activated while in Manual Mode or Low. Eaton's ServiceRanger diagnostic software can be used to enable Creep Mode in Automatic Mode and/or Reverse.

Engaging Creep Mode

To engage Creep Mode:

1. Select Low, Manual, or Automatic Mode, and the desired gear (while stopped or moving).
2. Apply the throttle pedal to accelerate the vehicle until the clutch is closed (engaged).

Automated and Automatic Transmissions

3. Release the throttle pedal. The vehicle will continue moving at governed low engine idle speed.

Exiting Creep Mode

To exit Creep Mode, apply the throttle pedal to accelerate temporarily, or select a higher gear in Manual Mode. (Creep Mode can be resumed in the selected gear by releasing the throttle pedal.)

NOTE: The transmission will exit Creep Mode if the engine lugs 150 rpm below the governed low engine idle speed. In this case, a lower gear should be selected if available.

Hill Start Aid

Eaton transmissions are equipped with a Hill Start Aid (HSA) feature to prevent the vehicle from rolling while on grades steeper than 3 percent and allow for a controlled launch. A grade sensor is used to determine when to engage the feature.

HSA is 'on' by default. It can be turned off by pressing and releasing the override switch on the dash (see [Chapter 4](#)). HSA will turn back on after the first successful launch.

When the vehicle is stopped on a grade greater than 3 percent and in a forward mode or reverse, depress the service brakes then release them. The vehicle will begin to move after 3 seconds, and the clutch will perform partial engagements to slow the vehicle motion. Either step on the brake or apply the throttle to continue negotiating the grade.

Engine Overspeed Protection

The system will upshift if necessary to prevent engine overspeed in Drive, Manual, and Low.

Shuttle Shifting

Shuttle shifting from reverse to any forward mode is only allowed if the vehicle speed is approximately zero.

Auto Start Gear Selection and Override

The transmission uses various inputs to automatically select the best start gear in Drive and Manual. This selection can be changed using the shift control; however, if the selection requested could cause damage or engine lugging, the request will be denied and a tone will sound.

Skip Shifting

When appropriate, the transmission may skip shift in Drive. When prevailing conditions like load and grade allow, skip shifts can be performed in Manual mode using the SmartShift control.

Auto Neutral

An Eaton automated transmission system will automatically shift to neutral if the vehicle is left in Drive and the parking brake is set. 'AN' will show on the gear display. To re-engage the transmission, select Neutral and then either Drive or Reverse on the shift control (it will re-engage regardless of whether the parking brake is released).

Automatic Traction Control

An Eaton automated transmission system requires the Automatic Traction Control (ATC) option to be enabled when driving in soft soil/sand to prevent wheel slippage and shifting issues.

With the ATC enabled, the system will engage the brakes on the wheel or side that the wheel slip is occurring to help the vehicle gain traction. The point at which the traction control will actuate the braking system increases with throttle: low throttle allows the system to brake the wheels earlier; heavy/full throttle raises the point of the acceptable wheel slip.

Adhere to the following points when driving with ATC enabled:

- If using Automatic mode in soft soil and/or sand, maintain the engine speed between 1000 and 1300 rpm to prevent unnecessary upshifting.
- If using Manual mode in soft soil and/or sand, do not attempt an upshift and try to maintain the current gear.
- If the vehicle comes to a stop in the sand it may be necessary to back up prior to attempting forward movement.

To disable the ATC, depress the ATC switch, shown in [Chapter 4](#). This mode allows for the drive axle wheels to spin.

Load-Based Shifting

An Eaton automated transmission system is adaptive and will change the shift points based on grade, engine RPM, throttle position, and vehicle load. After changing loads or powering up, the system needs to

Automated and Automatic Transmissions

relearn these inputs for the first few shifts to make the proper adjustments.

Coasting

When coasting to a stop on level terrain, the transmission system may not downshift into the lower gears. It will select a gear after the throttle is applied.

Transmission Low Air Warning

CAUTION

If the yellow "Caution: Transmission Air Supply Low" popup appears while the vehicle is in operation, slow down, safely pull the vehicle off the road, then correct the problem.

Pneumatic controls are used to shift the transmission. If there is inadequate air pressure, a yellow caution pop-up will appear and the quality of gear shifts may be degraded. See [Fig. 14.8](#). Wait for air pressure to build before operating the vehicle.

CAUTION

If the red "Warning: Transmission Will Not Shift" popup appears while the vehicle is in operation, choose the safest location available to pull the vehicle off the road. Prepare for the vehicle to be immobile if the problem cannot be resolved.

If a severe loss of air pressure occurs, a red warning pop-up will appear and the transmission will not shift. See [Fig. 14.9](#).

Transmission Prognostics

Some Eaton clutches require the application of grease for maintenance.

The Eaton transmission prognostics display can be found by navigating to the maintenance screens in the driver display. The screen will state if the Grease Interval is OK or if grease needs to be added. See [Fig. 14.11](#).

If the system status cannot be read, the message "SNA" displays.

Allison Automatic Transmissions

Refer to the Allison website for additional information: www.allisontransmission.com.

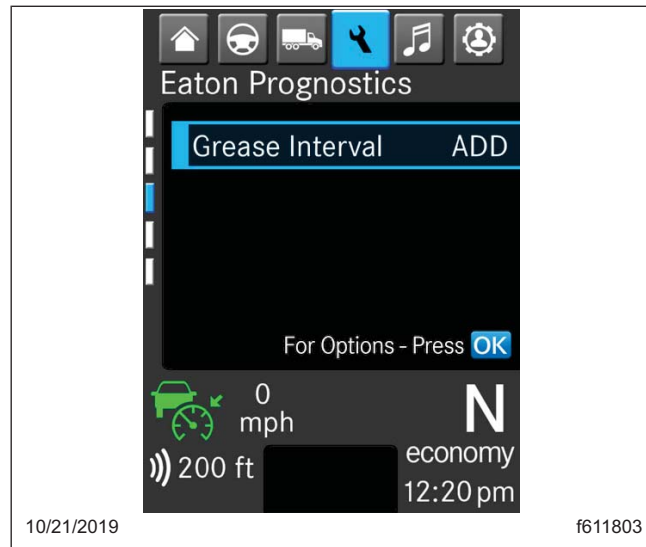

Fig. 14.11, Eaton Transmission Prognostics

General Information, Allison Transmissions

Allison transmissions have electronic shift controls that can be programmed to allow the use of different numbers of geared speeds. For instance, the transmission can be programmed to operate as a 4-speed, 5-speed, or 6-speed unit in the "primary" shift mode. If needed, a "secondary" shift mode can be programmed to provide another shift configuration to optimize vehicle use under different operating conditions. To activate a secondary shift mode, or other special functions programmed into the electronic control unit (ECU), briefly depress the mode switch on the multi-function stalk switch control; see [Fig. 14.1](#), item 3.

These transmissions use the multi-function stalk switch to select mode, direction, neutral, low, and to preselect lower ranges. The current gear, highest available gear, and mode are shown in the driver display; see [Fig. 14.12](#). Forward shifts can be made either automatically or by using Manual mode.

Operation Tips, Allison Transmissions

WARNING

Never shift from neutral (N) to drive (D) or reverse (R) at engine speeds above idle. The vehicle will lurch forward or backward, which could cause property damage and personal injury.

Automated and Automatic Transmissions

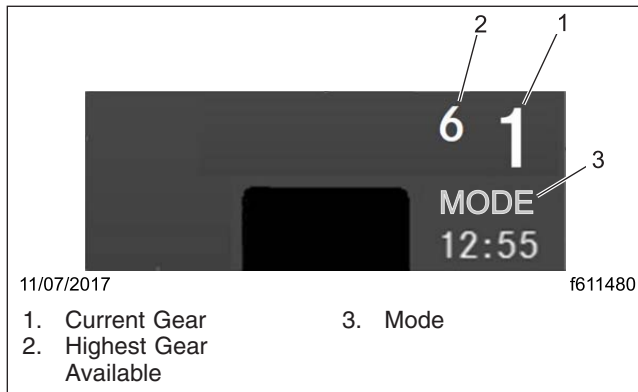

Fig. 14.12, Allison Gear Display in Automatic Mode

NOTICE

The engine should never be operated for more than thirty seconds at full throttle with the transmission in gear and the output stalled. Prolonged operation of this type will overheat the transmission fluid and will result in severe damage to the transmission.

NOTICE

Do not allow the vehicle to coast in neutral. This can result in severe transmission damage. Also, no engine braking is available.

The following tips highlight important operation principles.

- Use reverse (R) to back the vehicle. Completely stop the vehicle before shifting from a forward gear to reverse, or from reverse to forward.
- Select drive (D) for all normal driving conditions. The vehicle will start out in 1st gear (unless the transmission is programmed with 2nd gear start), and as speed increases, the transmission will upshift through each gear automatically. As the vehicle slows down, the transmission will downshift to the correct gear automatically.
- The pressure of your foot on the accelerator pedal influences the automatic shifting. When the pedal is fully depressed, the transmission will automatically upshift at higher engine speeds. A partially-depressed position of the pedal will cause the upshifts to occur at a lower engine speed.

- Occasionally the road, load, or traffic conditions make it desirable to restrict the automatic shifting to a lower range. The lower the gear range, the greater the engine braking power. When in Manual mode, push or pull on the multifunction stalk switch to reach the desired gear. In the lower gear ranges, the transmission will not upshift above the highest gear selected unless the hold override upshift speed is exceeded.
- Use neutral and apply the parking brake when the vehicle is parked with the engine running.

Automatic Mode (A)

In automatic drive mode, upshifts and downshifts are made by the transmission without driver intervention.

Automatic mode is the default start mode. If in manual mode, a short push on the shift control mode switch activates the automatic mode (A). Rotate the D/N/R switch to Drive (D), and press down on the throttle pedal. The transmission will shift automatically.

NOTE: If attempting to select a non-Neutral mode without applying the service brakes, the transmission will not shift into gear. To shift into gear, select Neutral, apply the service brakes, and select the desired mode again.

In Drive, the start gear is automatically selected. The transmission automatically performs upshifts and downshifts.

Manual Mode (M)

In manual mode, the driver selects the maximum allowed range. This may be helpful when traversing a work site, railroad tracks, or steep grades, for example.

When in automatic mode and with the D/N/R switch set to Drive (D), a long push on the shift control mode switch activates the manual mode (M). To increase selected range, pull the lever up (towards you); to decrease the selected range, push the lever down (away from you). The transmission will not upshift above the selected range unless the hold override upshift speed is exceeded.

See [Fig. 14.13](#) for an example of the driver display with the transmission in manual mode.

NOTE: The transmission may deny a downshift if the engine speed would fall outside of the acceptable range.

Automated and Automatic Transmissions

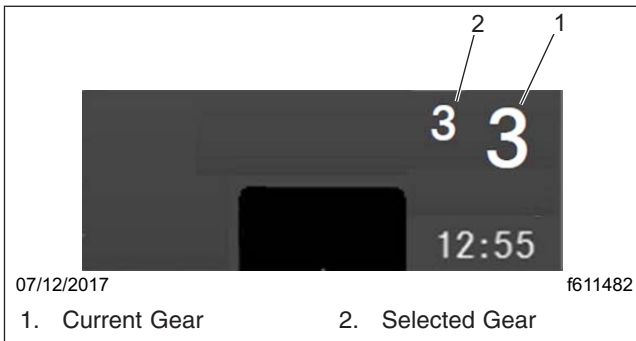

Fig. 14.13, Allison Gear Display in Manual Mode

NOTE: If attempting to select a non-Neutral mode without applying the service brakes, the transmission will not shift into gear. To shift into gear, select Neutral, apply the service brakes, and select the desired mode again.

Low (L)

Use Low when wanting to maximize engine braking and minimize the use of the brake pedal—for example, when driving down long grades or when coming to a stop. To select Low, push down on the multi-function stalk switch, and hold in the down-shift position for half a second or more. The lowest available start gear will be selected (the starting gear cannot be changed in Low).

If Low is selected while moving, the transmission will not upshift (unless the system initiates a Low override). The system will downshift at the earliest opportunity to provide maximum engine braking.

In the driver display, the low gear is shown as "1." See Fig. 14.14.



Fig. 14.14, Allison Gear Display in Low Gear

NOTE: If attempting to select a non-Neutral mode without applying the service brakes, the transmission will not shift into gear. To shift into gear, select Neutral, apply the service brakes, and select the desired mode again.

Transmission Prognostics

The Allison transmission prognostics display can be found by navigating to the maintenance screens in the driver display. The prognostics screen displays information on the transmission health status (oil filter status, oil level, and oil life). See Fig. 14.15. If transmission health falls below acceptable limits, a message will be shown on the driver display.

NOTE: For a valid oil level measurement, the vehicle must be stopped on a level surface with the transmission in neutral (N).

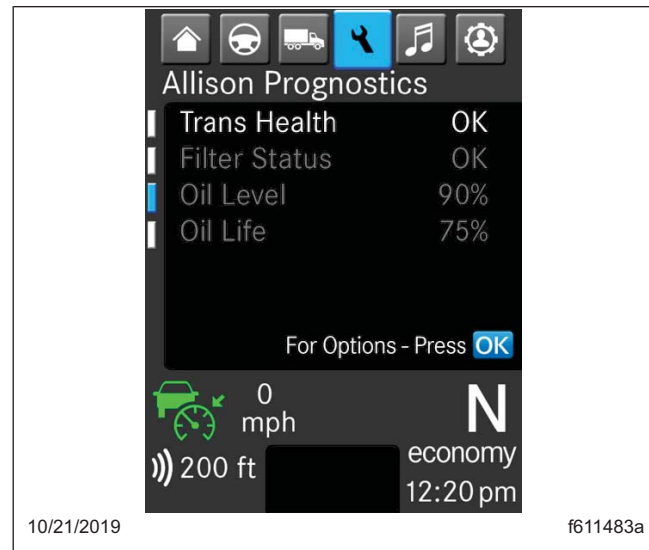

Fig. 14.15, Allison Transmission Prognostics

Allison On-Highway Transmissions

The Allison on-highway transmissions are fully automatic and include the 1000 Series™, 2000 Series™, and 2400 Series™. Refer to the Allison website for additional information, www.allisontransmission.com.

Automated and Automatic Transmissions

Safety Precautions



Do not leave the vehicle unattended with the engine running. If you leave the vehicle and the engine is running, the vehicle can move suddenly, which could result in personal injury or property damage.

1000 Series

On vehicles with Allison 1000 series transmissions, do the following steps if you have to leave the cab with the engine running (for example, when checking the transmission fluid):

Without Park Position

1. Bring the vehicle to a complete stop using the service brake.
2. Ensure that the engine is at low idle rpm.
3. Put the transmission in neutral.
4. Apply the parking brake, and make sure it is properly engaged.
5. Chock the rear tires and take any other steps necessary to keep the vehicle from moving.

With Park Position

1. Bring the vehicle to a complete stop using the service brake.
2. Ensure that the engine is at low idle rpm.
3. Put the transmission in P (park).
4. Apply the parking brake (if equipped), and make sure it is properly engaged.
5. Engage the park range by slowly releasing the service brake.
6. Chock the rear tires and take any other steps necessary to keep the vehicle from moving.

2000 Series

On vehicles with Allison 2000 series transmissions, do the following steps if you have to leave the cab with the engine running (for example, when checking the transmission fluid):

Without Auto-Apply Parking Brake

Follow the instructions for vehicles with 1000 series transmissions, under the heading "Without Park Position."

With Auto-Apply Parking Brake

1. Bring the vehicle to a complete stop using the service brake.
2. Ensure that the engine is at low idle rpm.
3. Put the transmission in PB (auto-apply parking brake).
4. Apply the parking brake (if equipped), and make sure it is properly engaged.
5. Chock the rear tires and take any other steps necessary to keep the vehicle from moving.

2400 Series

On vehicles with 2400 series transmissions, follow the instructions for vehicles with 1000 series transmissions.

Range Inhibit Indicator, 2000 and 2400 Series

A RANGE INHIBIT indicator is a standard feature of the 2000 series and 2400 series transmissions. The RANGE INHIBIT indicator comes on to alert the driver that transmission operation is being inhibited and that the range shifts being requested by the driver may not occur. When certain operating conditions are detected by the TCM (transmission control module), the controls will lock the transmission in the current operating range.

Shift inhibits occur under the following conditions:

- Shifts from neutral to reverse or from neutral to a forward range are not permitted when the engine is above idle (greater than 900 rpm).
- Forward/reverse directional shifts are typically not permitted if appreciable output shaft speed is detected.
- When some types of unusual transmission operating conditions are detected by the TCM, the TCM temporarily limits transmission operation until the vehicle can be driven to a service location. When this type of situation is detected, the TCM will lock the transmission in a safe gear range.

Automated and Automatic Transmissions

- The TCM will prevent shifts from park or neutral to range when auxiliary equipment, such as a power takeoff unit (PTO), is in operation.

Operating Instructions, On-Highway Transmissions

Allison automatic transmissions are electronically controlled. The shift selector provides five or six forward ranges and one reverse range.

P (Park, optional on 1000 and 2400 Series)

Use park when turning the engine on or off, to check vehicle accessories, to operate the engine in idle for longer than 5 minutes, and for stationary operation of the power takeoff, if equipped. This position places the transmission in neutral and engages the park pawl of the transmission.

NOTE: This does not apply the parking brake.

PB (Auto-Apply Parking Brake, optional on 2000 Series)

WARNING

Before selecting PB on the shift lever, make sure the ignition switch is not in the OFF position. Selecting PB with the ignition switch in the OFF position places the transmission in neutral, but does not apply the parking brake automatically. The vehicle could roll unexpectedly, possibly causing property damage or personal injury.

The auto-apply parking brake places the transmission in neutral and applies the parking brake.

NOTE: Selecting PB on the shift lever does not engage the park pawl of the transmission.

R (Reverse)

Reverse is used to back the vehicle. When the selector is in reverse, the reverse warning signal will sound. Always bring the vehicle to a complete stop before shifting from a forward range to reverse, or from reverse to a forward range.

NOTICE

Extended idling in reverse may cause transmission overheating and damage.

Do not idle in reverse for more than 5 minutes. Select P (park), PB (auto-apply parking brake), or N (neutral) when time at idle exceeds 5 minutes.

NOTE: The shift into reverse may not succeed if a range inhibitor is active. Check for illumination of the RANGE INHIBIT indicator.

N (Neutral)

The neutral position places the transmission in neutral. This position is used when starting the engine and for stationary operation.

WARNING

Failure to apply the vehicle parking brakes when the transmission is in neutral may allow the vehicle to move unexpectedly, possibly causing property damage or personal injury.

When neutral is selected, the vehicle service brakes, parking brake, or emergency brake must be applied. Selecting neutral does not apply vehicle brakes unless an auxiliary system to apply the parking brake is installed.

WARNING

Do not coast in neutral. Coasting in neutral can cause an accident, possibly resulting in severe personal injury or death.

Do not let the vehicle coast in neutral. If the vehicle is allowed to coast in neutral, the engine brake will not work and you could lose control of the vehicle.

NOTICE

Coasting in neutral can cause severe transmission damage.

D (Drive)

WARNING

When going downhill, use a combination of downshifting, braking, and other retarding devices to control vehicle speed and the engine's rated governed speed. Failure to do so could

Automated and Automatic Transmissions

reduce vehicle braking, possibly causing loss of vehicle control and resulting in personal injury or property damage.

In the drive position, the transmission will initially go into first range when drive is selected. As vehicle speed increases, the transmission will upshift automatically through each available range up to fourth range or fifth range. As the vehicle slows, the transmission will downshift automatically.

When going downhill, downshift to a lower transmission range to increase engine braking and to help maintain control. The transmission has a feature to prevent automatic upshifting above the lower range selected. However, during downhill operation, the transmission may upshift to the next higher range, if the engine is exceeding its governed speed in the lower range.

NOTICE

Do not idle in drive for more than 5 minutes. Extended idling in drive may cause transmission overheating and damage. Always select PB (auto-apply parking brake) or P (park) if time at idle is longer than 5 minutes.

NOTE: The shift into drive may not succeed if a range inhibitor is active. Check for illumination of the RANGE INHIBIT indicator.

4 and 3 (Fourth and Third Ranges, optional)

Use the fourth or third range for city traffic and for braking on steep downgrades.

3 and 2 (Third and Second Ranges, standard)

Use the third or second range for heavy city traffic and for braking on steeper downgrades.

1 (First Range)

Use first range when pulling through mud or deep snow, when maneuvering in tight spaces, or when driving up or down very steep grades. First range provides the vehicle with its maximum driving torque and maximum engine braking effect.

NOTE: To have the transmission select these ranges automatically, leave the selector lever in D (drive).

Allison Transmission® MD Series

Refer to the Allison website for additional information, www.allisontransmission.com.

Safety Precautions



Do not leave the vehicle unattended with the engine running. If you leave the vehicle and the engine is running, the vehicle can move suddenly, which could result in personal injury or property damage.

On vehicles with MD series transmissions, do the following steps if you have to leave the cab with the engine running (for example, when checking the transmission fluid):

1. Bring the vehicle to a complete stop using the service brake.
2. Put the transmission in N (neutral).
3. Ensure that the engine is at low idle (500 to 800 rpm).
4. Apply the parking brake and emergency brakes, and make sure they are properly engaged.
5. Chock the rear tires and take any other steps necessary to keep the vehicle from moving.

Operating Instructions, MD Series

The Allison MD transmission is electronically controlled and comes with a push-button shift control that provides five or six forward ranges and one reverse range. The push-button shift selector has an R (reverse), an N (neutral), a D (drive), an up arrow, a down arrow, a mode button, and a digital display.

New shift controls — known as fourth generation — were introduced in mid-2006. They replaced the previous units that are commonly referred to as WTEC III. See [Fig. 14.16](#) and [Fig. 14.17](#).

R (Reverse)

Press the R button to select reverse. The digital display will show R when reverse is selected. Always bring the vehicle to a complete stop and let the engine return to idle before shifting from a forward range to reverse, or from reverse to a forward range.

Automated and Automatic Transmissions

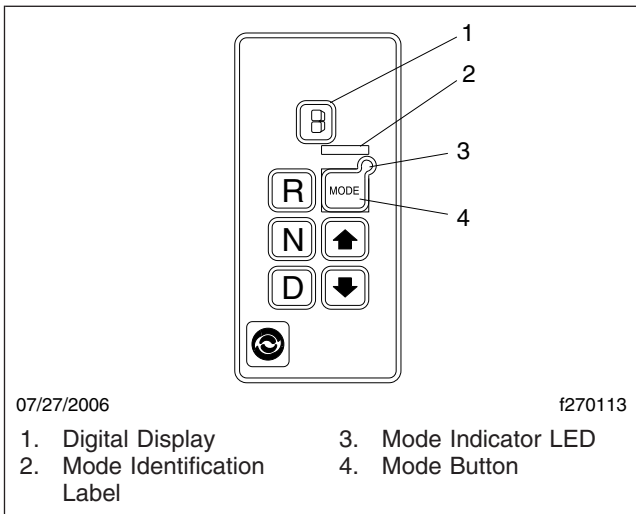

Fig. 14.16, WTEC III Push-Button Shift Selector

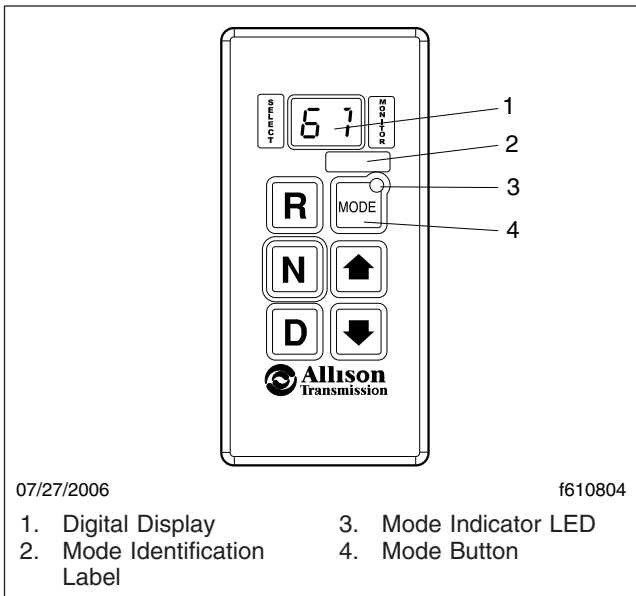

Fig. 14.17, Fourth Generation Push-Button Shift Selector

NOTICE

Extended idling in reverse may cause transmission overheating and damage.

Do not idle in reverse for more than 5 minutes. Select neutral when time at idle exceeds 5 minutes.

NOTE: The shift into reverse may not succeed if a range inhibitor is active. When reverse is selected, always be sure that R is not flashing.

N (Neutral)

⚠ WARNING

When starting the engine, make sure that the service brakes are applied. Failure to apply the service brakes may result in unexpected vehicle movement, which could cause severe personal injury or death. Failure to apply the vehicle parking brakes when the transmission is in neutral may allow the vehicle to move unexpectedly, possibly causing property damage or personal injury.

Press the N button to select neutral. The digital display will display N when neutral is selected. It is not necessary to press neutral before starting the vehicle. The ECU (electronic control unit) or TCM (transmission control module) automatically places the transmission in neutral at start-up.

⚠ WARNING

Failure to apply the vehicle parking brakes when the transmission is in neutral may allow the vehicle to move unexpectedly, possibly causing property damage or personal injury.

When neutral is selected, the vehicle service brakes, parking brake, or emergency brake must be applied. Selecting neutral does not apply vehicle brakes unless an auxiliary system to apply the parking brake is installed.

⚠ WARNING

Do not coast in neutral. Coasting in neutral can cause an accident, possibly resulting in severe personal injury or death.

Do not let the vehicle coast in neutral. If the vehicle is allowed to coast in neutral, the engine brake will not work and you could lose control of the vehicle.

Always select neutral before turning off the engine. Neutral is also used during stationary operation of the power takeoff if your vehicle is equipped with a PTO.

D (Drive)

When the D button is pushed, the highest forward range will appear in the display. The transmission will normally go into first range when drive is selected (except for those units programmed to start in second range). As vehicle speed increases, the

Automated and Automatic Transmissions

transmission will upshift automatically through each range. As the vehicle slows, the transmission will downshift automatically.

NOTICE

Do not idle in drive for more than 5 minutes. Extended idling in drive may cause transmission overheating and damage. Always select neutral if time at idle is longer than 5 minutes.

NOTE: The shift into drive may not succeed if a range inhibitor is active. When drive is selected, always be sure that D is not flashing.

5, 4, 3, and 2 (Fifth, Fourth, Third, and Second Ranges)

Occasionally, road conditions, load, or traffic conditions will make it desirable to restrict automatic shifting to a lower range. Lower ranges provide greater braking for going down grades. The lower the range, the greater the braking effect.

Push the up or down arrows on the push-button shift selector to select individual forward ranges. The digital display will display your choice of range. When a lower range is selected, the transmission may not downshift until the vehicle speed or engine RPM (engine governed speed) is reduced.

WARNING

When going downhill, use a combination of downshifting, braking, and other retarding devices to control vehicle speed and the engine's rated governed speed. Failure to do so could reduce vehicle braking, possibly causing loss of vehicle control and resulting in personal injury or property damage.

When going downhill, downshift to a lower transmission range to increase engine braking and to help maintain control. The transmission has a feature to prevent automatic upshifting above the lower range selected. However, during downhill operation, if the engine governed speed is exceeded in the lower range, the transmission may upshift to the next higher range.

1 (First Range)

Use the first range when pulling through mud or deep snow, when maneuvering in tight spaces, or when driving up or down steep grades. First range provides the vehicle with its maximum driving torque

and maximum engine braking effect. Push the down arrow until the first range appears on the display.

Up and Down Arrows

When a lower range is desired, after D has been pressed, press the down arrow until the desired range is shown on the display. Pressing the down arrow continuously causes the range position to continue to go down until the button is released or the lowest range is attained.

When the transmission is in drive and the down arrow has the transmission in a lower range position, press the up arrow to shift to a higher selector position. Pressing the up arrow continuously causes the range position to continue to rise until the button is released or the highest available position is attained.

Pressing the up or down arrows does not override the transmission automatic shifting operation. If a higher or lower position is selected, the transmission continues shifting through the ranges according to the vehicle operating characteristics until the highest or lowest selected position is reached.

Mode Button

The MODE button starts a specialized input or output function that has been previously programmed into the ECU or TCM. Pressing the MODE button changes transmission operation for a specific function.

Mode Indicator LED

When the MODE button is pressed, the mode indicator LED illuminates. A mode identification label, located above the MODE button, identifies the function associated with a mode change.

Digital Display

The dual digital display shows both the selected range (SELECT) and actual range attained (MONITOR). The single digital display shows the selected range.

Oil Level Sensor

Allison MD Series transmissions have an electronic oil level sensor to read fluid level information. The fluid level diagnostic will display whether the oil level is OK, too low, or too high. It will also display a default code and indicate if the preconditions (of receiving the fluid level information) are not met.

Automated and Automatic Transmissions

IMPORTANT: Maintain the proper fluid level at all times. If the fluid level is too low, the converter and clutch do not receive an adequate supply of fluid. If the level is too high, the transmission may shift erratically or overheat.

To access the oil level display mode, park the vehicle on a level surface, shift to N (neutral), apply the parking brake, and idle the engine. Then simultaneously press both the up and down arrows once. The oil level will display at the end of a two-minute countdown.

Diagnostic Codes

Diagnostic codes are numerical indications relating to a malfunction in transmission operation. These codes are logged in the TCM/ECU memory. The most severe or most recent code is listed first. A maximum of five codes (numbered d1-d5) may be listed in memory at one time. If the mode indicator LED is illuminated, the displayed code is active. If it is not illuminated, the displayed code is not active.

NOTE: During normal operation, an illuminated mode indicator LED signifies the specialized mode operation is in use.

To enter diagnostics mode, first park the vehicle and apply the parking brake. Then simultaneously press both the up and down arrows twice.

15

Manual Transmissions, Clutch, and Transfer Cases

Eaton® Manual Transmissions	15.1
Eaton® Straight-Shift Transmissions	15.1
Eaton® Range-Shift Transmissions	15.2
Clutch	15.5
Meritor MTC Series Transfer Cases	15.6

Manual Transmissions, Clutch, and Transfer Cases

Eaton® Manual Transmissions

General Information

A Freightliner M2 Plus vehicle may be equipped with an Eaton manual transmission. Vehicles with Eaton manual transmissions have clutch brakes and a hydraulic clutch actuation system.

The transmission shift pattern is printed on a decal attached to the driver-side sun visor or to the dash below the center dash panel. The shift pattern may also be printed on the shift knob.

NOTE: For additional information, refer to the Eaton website, <http://dtna.info/EatonTransmissionInfo>.

Transmission Operation Tips

Follow these important operation principles:

- For all conditions, use the highest gear that is still low enough to start the vehicle moving with the engine at or near idle speed, and without slipping the clutch excessively.

When operating on-highway with no load or under ideal conditions, use 1st gear to start the vehicle moving forward.

When operating off-road or under adverse conditions, use LOW gear to start the vehicle moving forward.

- Use the clutch brake to stop gear rotation when shifting into LOW or reverse while the vehicle is stationary. The clutch brake is actuated by depressing the clutch pedal all the way to the floor.
- Partially disengage the clutch to break engine torque during normal gear shifts.
- Double-clutch between all upshifts and downshifts that require movement of the shift knob. Splitting of gears does not require movement of the shift knob.
- Never push the range-preselection lever down into low range while operating in high range, except when downshifting from 5th gear to 4th gear.
- Do not shift from high range to low range at high vehicle speeds.
- Never make a range shift or a splitter shift while the vehicle is in reverse.

- Never move the range-preselection lever with the transmission in neutral while the vehicle is moving.
- Skip ratios while shifting *only* when operating conditions permit, depending on the load, grade, and road speed.
- Never coast with the transmission in neutral.

Eaton® Straight-Shift Transmissions

Refer to the Eaton website for additional information, <http://dtna.info/EatonTransmissionInfo>.

General Information, Straight-Shift

Eaton Fuller 5-speed FS models are fully synchronized. They have five forward speeds and one reverse. See [Fig. 15.1](#) for the shift pattern.

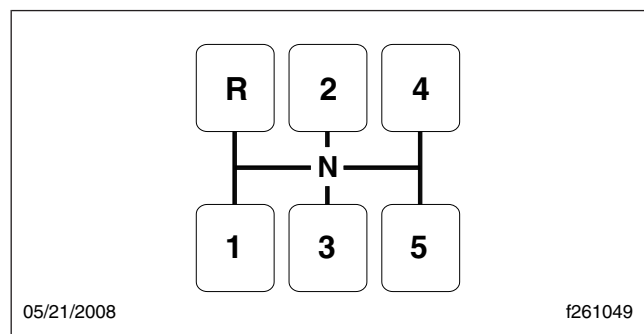

Fig. 15.1, Shift Pattern, 5-Speed FS Models

Eaton Fuller 6-speed FS and FSO models are fully synchronized. They have six forward speeds and one reverse. See [Fig. 15.2](#) for the shift pattern.

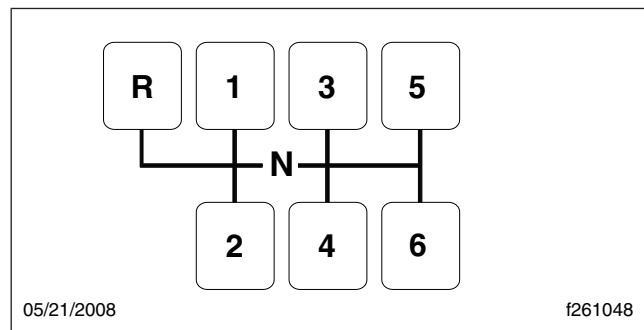

Fig. 15.2, Shift Pattern, 6-Speed FS and FSO Models

Manual Transmissions, Clutch, and Transfer Cases

Eaton Fuller 7-speed T models are not synchronized. They have seven forward speeds and one reverse. See [Fig. 15.3](#) for the shift pattern.

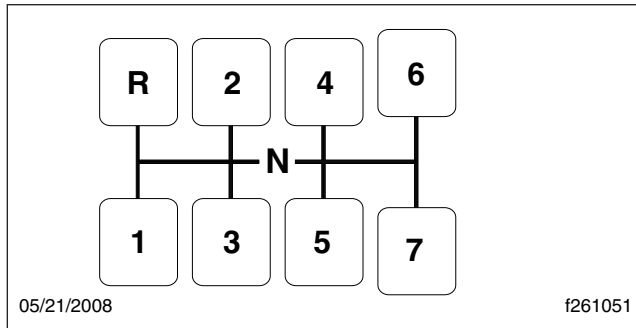

Fig. 15.3, Shift Pattern, 7-Speed T Models

These transmissions are designed for use with on-highway, fuel economy engines where a minimum of shifting is desired and less gear reduction is acceptable.

Operation, Straight-Shift

1. Always use first gear when starting to move the vehicle forward.

IMPORTANT: Do not rest your foot on the clutch pedal while driving. This causes partial clutch disengagement which could cause premature clutch wear.

2. On synchronized models, press the clutch pedal to the floor when shifting gears. Double-clutching is unnecessary.

On unsynchronized models, press the clutch pedal to the floor to contact the clutch brake only when engaging the first or reverse gears.

NOTE: If the vehicle is moving when shifting, press the clutch pedal just far enough to disengage the clutch. Pressing it to the floor will engage the clutch brake, if so equipped, causing premature clutch brake wear.

3. To upshift, do the following steps:
 - 3.1 Accelerate to engine governed speed.
 - 3.2 On synchronized models, disengage the clutch and move the shift lever to second gear.

On unsynchronized models, disengage the clutch and move the shift lever to neutral. Engage the clutch again. With the shift lever in neutral, disengage the clutch and move the shift lever to second gear.

- 3.3 Engage the clutch and note the drop in engine rpm before accelerating up to engine governed speed again.
- 3.4 Continue upshifting using the same sequence described in the previous step. Follow the pattern on the shift lever.
4. To downshift, do the following steps:
 - 4.1 Wait until the engine speed drops to the rpm noted immediately after the upshift.
 - 4.2 On synchronized models, disengage the clutch and move the shift lever to the next lower gear.

On unsynchronized models, disengage the clutch and move the shift lever to neutral. Engage the clutch again. With the shift lever in neutral, disengage the clutch and move the shift lever to the next lowest gear.
 - 4.3 Engage the clutch smoothly.
 - 4.4 Use the sequence described above to shift progressively down through each successive lower gear, as driving conditions require.

Eaton® Range-Shift Transmissions

Refer to the Eaton website for additional information, <http://dtna.info/EatonTransmissionInfo>.

General Information, Range-Shift

Eaton Fuller 9-Speed Models

Eaton Fuller 9-speed range-shift models are not synchronized. They have nine forward speeds and two reverse speeds. The shift lever controls five forward gears and one reverse gear in the transmission front section, and the range lever controls a LO and HI range in the two-speed auxiliary section. The first position in the front section is used only as a starting gear. The other four ratios are used once in LO range and once again in HI range. See [Fig. 15.4](#) for the shift patterns.

Manual Transmissions, Clutch, and Transfer Cases

After shifting out of the first gear position, use the Roadranger® "repeat H" shift pattern. Select both LO range and HI range with the range lever (range knob). It is used once during the upshift sequence and once during the downshift sequence.

Always preselect the range shift. After preselection, the transmission will automatically make the synchronizer range shift as the shift lever passes through neutral.

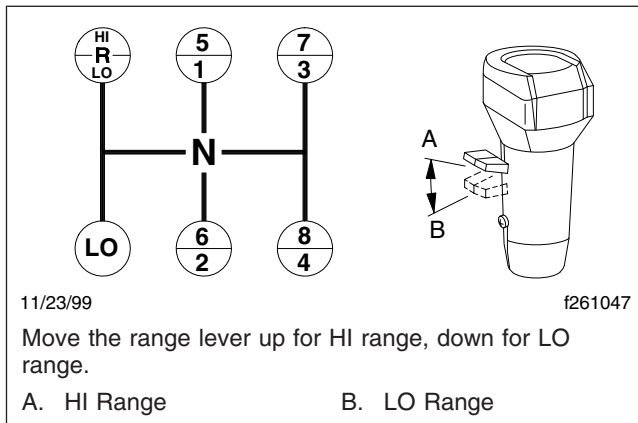

Fig. 15.4, Shift Pattern, 9-Speed Models

Eaton Fuller 10-Speed Models

Eaton Fuller 10-speed range-shift models are not synchronized. They have ten forward speeds and two reverse speeds. The shift lever controls five forward gears and one reverse gear in the transmission front section, and the range lever controls a LO and HI range in the two-speed auxiliary section. The five forward gears selected in LO range are used again in HI range to provide the 10 progressive forward gears. See Fig. 15.5 for the shift patterns. See Table 15.1 for the shift progressions.

Once the highest shift lever position (fifth gear) is reached in LO range, the driver preselects the range shift lever for HI range. The range shift occurs automatically as the shift lever is moved from fifth gear position to the sixth gear position.

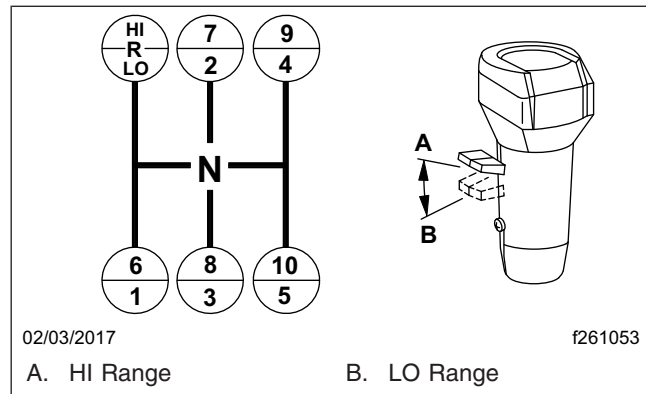

Fig. 15.5, Shift Pattern, 10-Speed Models

Eaton Fuller Shift Progressions			
Model	LO Range		HI Range
	Off-Highway	On-Highway	
9-Speed Direct or Overdrive	 f260322	 f260323	 f260324
10-Speed Direct or Overdrive	 f260329	 f260329	 f260330

Table 15.1, Eaton Fuller Shift Progressions

When downshifting, the driver preselects the range lever for LO range and the range shift occurs automatically during the shift lever movement to the next gear position.

Eaton Fuller Deep-Reduction Models

Eaton Fuller deep-reduction models are not synchronized. They have a five-speed front section and a two-speed auxiliary section which has an extra deep reduction gear. The LO gear in the front section is used only as a starting gear. The other four ratios are used once in LOW RANGE and once in HIGH RANGE giving eight highway ratios. LO-LO is selected by the DEEP REDUCTION lever on the dashboard. See Fig. 15.6 for the shift pattern.

Operation, Range-Shift

1. When operating off-highway or under adverse conditions, always use low gear when starting to move the vehicle.

Manual Transmissions, Clutch, and Transfer Cases

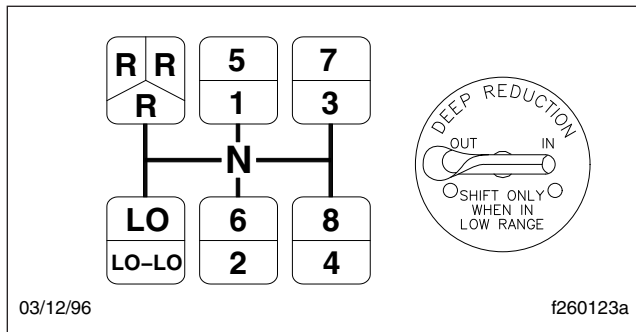

Fig. 15.6, Shift Pattern, Deep Reduction

When operating on-highway, with no load or under ideal conditions, use first gear when starting to move the vehicle.

For all conditions, use the highest gear that is still low enough to start the vehicle moving with the engine idling and without excessively slipping the clutch.

2. Use the clutch brake to stop gear rotation when shifting into low (or first) or reverse when the vehicle is stationary. The clutch brake is applied by pressing the clutch pedal all the way to the floor.

For normal upshifts and downshifts, only a partial disengagement of the clutch is necessary to break engine torque.

3. Do not make range shifts with the vehicle moving in reverse gear.
4. Never attempt to move the range preselection lever with the gear shift lever in neutral while the vehicle is moving. Preselection with the range preselection lever must be made prior to moving the shift lever out of gear into neutral.
5. Do not shift from high range to low range at high vehicle speeds.
6. Use double-clutching between all upshifts and downshifts.
7. After your shifting ability improves, you may want to skip some of the ratios. This may be done only when operating conditions such as load, grade, and road speed permit.

Upshifting

1. Position the gear shift lever in neutral. Start the engine and bring the air system pressure up to 100 to 120 psi (689 to 827 kPa).

2. Position the range preselection lever down into low range.
3. Press the clutch pedal to the floor. Shift into low or first gear, then engage the clutch with the engine at or near idle speed to start the vehicle moving. Accelerate to 80 percent of engine governed speed.
4. Shift progressively up from low or 1st gear to the top gear in low range, double-clutching between shifts and accelerating to 80 percent of engine governed speed.
5. While in the top gear of the low-range shift pattern and ready for the next upshift, flip the range preselection lever up into high range. Double-clutch through neutral and shift into the bottom gear in high range. As the shift lever passes through neutral, the transmission will automatically shift from low range to high range.
6. With the transmission in high range, shift progressively up through each of the high range gears, double-clutching between shifts.

Downshifting

1. With the transmission in high range, shift progressively down to the bottom gear in high range, double-clutching between shifts.
2. When in the bottom gear of the high-range shift pattern and ready for the next downshift, push the range preselection lever down into low range. Double-clutch through neutral and shift into the top gear of the low-range shift pattern. As the shift lever passes through neutral, the transmission will automatically shift from high range to low range.
3. With the transmission in low range, downshift through the low range gears as conditions require.

Never use the clutch brake when downshifting or as a brake to slow the vehicle.

Operation, Deep-Reduction Models

Upshifting

1. Position the gear shift lever in neutral. See [Fig. 15.6](#) for the shift pattern. Start the engine, and bring the air system pressure up to 95 to 125 psi (655 to 862 kPa).
2. Position the range preselection lever down, into low range.

Manual Transmissions, Clutch, and Transfer Cases

NOTE: If conditions are difficult, start out in LO-LO. Move the DEEP REDUCTION lever on the dashboard to the IN position. Otherwise start out in LO with the DEEP REDUCTION lever in the OUT position.

3. Depress the clutch pedal to the floor. Shift into LO gear; then, engage the clutch, with the engine at or near idle rpm to start the vehicle moving. The vehicle will start in LO or LO-LO depending on the DEEP REDUCTION lever position.
4. To upshift if in LO-LO, move the DEEP REDUCTION lever to the OUT position and *immediately* release the accelerator, depress the clutch pedal once to break torque, and reengage the clutch. The auxiliary section will shift from LO-LO to LO when the gears reach the same speed.
5. Shift progressively upward from LO through 1st, 2nd, 3rd, and 4th gears while the range preselection lever is in LO. Always double-clutch between gears.
6. When in 4th gear and ready for the next upshift, pull up the range preselection lever and move the shift lever, double-clutching, to the 5th gear position. As the shift lever passes through neutral, the auxiliary section will automatically shift from low to high range.

NOTICE

Never move the shift lever into the LO gear position after high range preselection or anytime the auxiliary section is in high range. Transmission damage could result.

7. Continue upshifting from 5th gear through 8th gear, always double-clutching between gears.

Downshifting

1. While in high range, move the gear shift lever from 8th gear through 5th gear as conditions require, always double-clutching between gears.
2. When in 5th gear and ready for the next downshift, push down the range preselection lever and move the shift lever to the 4th gear position, being sure to double-clutch. As the shift lever passes through neutral, the auxiliary section will automatically shift from high to low range.

3. While in the low range, continue downshifting from 4th through LO as conditions require, always double-clutching between gears.
4. *Do not* downshift into LO-LO from LO unless operating conditions make it necessary. If it is necessary, make sure that the shift lever is in the LO gear position and the auxiliary section is in the low range. Then, move the DEEP REDUCTION lever on the dashboard to the IN position. *Immediately* release the accelerator, depress the clutch pedal once to break torque, engage the clutch, and accelerate. The auxiliary section will automatically shift from LO to LO-LO when the gears reach the same speed.

NOTICE

Never use the clutch brake when downshifting, or as a brake to slow the vehicle. This will cause premature clutch brake wear.

Clutch

General Information

The hydraulic clutch control system consists of a pedal unit and a slave cylinder connected by a hydraulic hose. The components of the system have been specially designed to use DOT 4 brake fluid. The hydraulic system is self-adjusting.

Typical operation will not break down the clutch friction surfaces. Heat and wear are almost nonexistent when a clutch is fully engaged. However, during the moment of engagement, when the clutch is picking up the load, considerable heat is generated. If a clutch slips excessively, high temperatures develop quickly between the flywheel, driven discs, and pressure plates. An improperly adjusted or slipping clutch can generate temperatures high enough to cause the friction-facing material to char and burn, destroying the clutch.

To ensure long service life of the clutch, start in the right gear and be alert to clutch malfunctions.

Clutch Operation

Clutch Break-In

With a new or newly installed clutch, the clutch may slip for a short time while the friction surfaces break-in. However, allowing the clutch to slip for more than two seconds can severely damage the clutch disc, pressure plate, and the flywheel.

Manual Transmissions, Clutch, and Transfer Cases

During initial operation of a new vehicle or a vehicle with a new clutch, check for clutch slippage during acceleration. If the clutch slips, decelerate until the clutch does not slip. Allow the clutch to cool 15 to 30 seconds, and then gradually accelerate again. If the clutch continues to slip, repeat the procedure. If necessary, repeat the procedure up to five times. If the clutch slips after five attempts, stop the vehicle. Allow the clutch to cool for at least one hour. Notify your Freightliner dealer of the problem.

NOTICE

Do not allow sustained slippage of the clutch; this could severely damage the clutch disc, pressure plate, or flywheel. Damage caused by clutch slippage due to improper break-in is not warrantable.

Using the Clutch Brake

The clutch brake is applied by depressing the clutch pedal past the fully released clutch position, almost to the floor plate. The last part of the clutch pedal travel will compress the clutch brake plates together, stopping the transmission input shaft. The purpose of the clutch brake is to stop the transmission gears from rotating in order to quickly engage a transmission gear after idling in neutral.

NOTICE

Never apply the clutch brake when the vehicle is moving. If the clutch brake is applied when the vehicle is moving, the clutch brake will try to stop or decelerate the vehicle, causing rapid wear of the clutch brake friction discs. Considerable heat will be generated, causing damage to the release bearings and the transmission front bearings.

Holding the Vehicle on an Incline

Always use the vehicle service brakes to prevent the vehicle from rolling backwards while stopped on a hill. Slipping the clutch on a hill to maintain the vehicle position will quickly damage the clutch assembly.

Coasting

Coasting with the clutch pedal depressed and the transmission in a low gear can cause high driven disc speed. The clutch speed can be much higher under these conditions than when the engine is

driving the clutch. This condition creates a hazardous situation due to the lack of vehicle control and due to the high clutch disc speed. Engaging the clutch under these conditions can cause component damage because of the shock loads to the clutch and drivetrain.

WARNING

Always shift into the gear that is correct for the traveling speed of the vehicle and engage the clutch. Coasting with the clutch disengaged can prevent engagement of the correct transmission gear which can cause loss of vehicle control, possibly resulting in personal injury or property damage.

High clutch disc speeds while coasting can also cause the clutch facing to be thrown off the disc. Flying debris from the clutch can cause injury to persons in the cab.

Clutch Adjustment

Eaton Fuller Solo clutches are adjustment-free. As the clutch wears, its wear-adjusting technology monitors clutch components and makes any necessary adjustments. The wear adjusting technology comes from two sliding cams, which rotate to maintain the proper adjustment. Atop the upper cam, a wear indicating tab mirrors the cam's movement, letting you know when it's time to replace the clutch.

Meritor MTC Series Transfer Cases

Meritor MTC Series

Some vehicles are equipped with a Meritor MTC Series transfer case for part-time 4x4, 6x6, or 8x8 operation. Meritor MTC Series transfer cases have two gear sets: HIGH RANGE and LO RANGE.

WARNING

Do not engage a Meritor MTC Series transfer case when driving on normal highway conditions. Severe personal injury and/or damage to components can result when the transfer case is misused.

IMPORTANT: Steer axle engagement is limited to 20 percent or less of annual vehicle mileage.

Manual Transmissions, Clutch, and Transfer Cases

Follow the operating guidelines in [Table 15.2](#) when driving a vehicle equipped with a Meritor MTC transfer case.

Engaging and Disengaging the Steer Axle

Dash-mounted switches control the transfer case functions; see [Chapter 4](#) for more information.

IMPORTANT: The wheels must not slip during engagement of the steer axle driveline.

To engage the steer axle driveline, drive the vehicle at a constant speed below 10 mph (16 km/h) and

press the AWD switch. An audible engagement may be heard.

To disengage the steer axle, drive the vehicle at a constant speed below 10 mph (16 km/h) and press the AWD switch. An audible disengagement may be heard. If the steer axle driveline does not disengage, the steer axle driveline coupling may be in a bind. Turn the steering wheel back and forth while driving, or briefly drive the vehicle in reverse.

Range	Disengaged Steer Axle		Engaged Steer Axle	
	Traction Conditions	Applicable Vehicle Speeds	Traction Conditions	Applicable Vehicle Speeds
HIGH RANGE	Most normal driving conditions (such as dry or wet pavement or mixed road surfaces) when moderate to high vehicle speeds are appropriate.	0 mph (0 km/h) to maximum vehicle speed	When more traction is needed at moderate to low vehicle speeds on dirt or gravel surface with shallow to moderate grades (8% maximum), icy or snow-covered roads, or hard-packed sand.	20 mph (32 km/h) or less
LO RANGE	Not applicable. Do not use LO RANGE unless the steer axle is engaged.		When maximum power and maximum traction is needed on steeper grades (15% maximum), deeply rutted tracks, deep mud or snow, extremely rocky surfaces, or soft, loamy sand.	15 mph (24 km/h) or less

IMPORTANT: Engaging the steer axle will increase the turning radius of the vehicle.

Table 15.2, Operating Guidelines, Meritor MTC Transfer Cases

Shifting Between HIGH RANGE and LO RANGE

MTC Series transfer cases use an air cylinder to shift between HIGH RANGE and LO RANGE. A dash-mounted switch operates the shift mechanism (see [Chapter 4](#) for more information).

Shift between HIGH RANGE and LO RANGE, as follows:

1. Stop the vehicle.
2. Shift the transmission to NEUTRAL.
3. Apply the parking brake.
4. Move the dash-mounted switch to the HIGH or LO RANGE position to pressurize the shift mechanism in the transfer case. An audible engagement may be heard (which is normal).

5. Shift the transmission to FIRST gear and apply light torque to test the engagement.

If the shifter does not engage when shifting from HIGH RANGE to LO RANGE, shift the transmission into REVERSE, then NEUTRAL, and apply light torque to engage the LO RANGE.

Engaging PTO

Some vehicles are equipped with a PTO mounted to a Meritor MTC transfer case. For these vehicles, engage the PTO only when the transfer case is in neutral, the transmission is in neutral/park, and the parking brake is applied. To begin using the PTO, select the drive gear based on the PTO system operators manual.

16

Drive Axles

Meritor™ Drive Axles	16.1
Driver-Controlled Differential Lock (DCDL)	16.4
Interaxle Lock, Tandem Axles	16.6

Drive Axles

Meritor™ Drive Axles

Refer to the Meritor website for additional information, www.meritor.com.

Drive Axles With Differential Lock

The Meritor driver-controlled differential lock feature (side-to-side wheel lock, traction control, or traction equalizer) is available on single-drive or dual-drive rear axles. It is available on both axles of a dual-drive vehicle, or on one only. It is only available on drive axles. Differential lock must only be used under adverse road conditions where greater traction is needed. With differential lock on, the turning radius is increased and vehicle handling is affected. The differential lock switch, shown in **Fig. 16.1**, allows the driver to lock the wheels on the same axle together. The red differential lock warning light illuminates on the dash message center when differential lock is engaged.

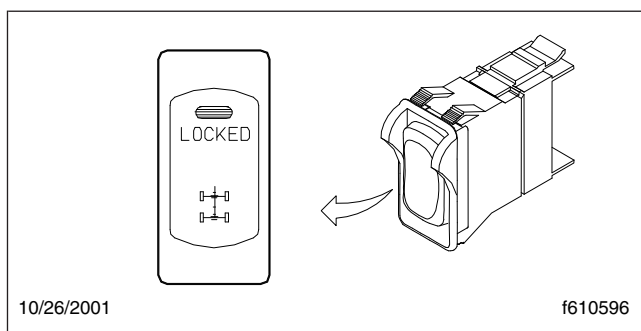

Fig. 16.1, Differential Lock Switch

Differential lock provides maximum traction under slippery conditions. When the differential lock is engaged, the clutch collar completely locks the differential case, gearing, and axle shafts together, maximizing the traction of both wheels and protecting against spinout.

Under normal traction conditions, do not use the differential lock feature.

Differential Lock Switch

NOTICE

Differential lock should only be engaged when the vehicle is stopped or moving slowly at low throttle. This will prevent internal axle damage.

Normally, when differential lock is available on dual-drive vehicles, one switch activates the lock on both

rear drive axles. As an option, it possible to have two differential lock switches, one for the forward rear and one for the rearmost drive axle. It is also possible for some vehicles to have differential lock on only one of the drive axles.

A two-position guarded rocker switch, shown in **Fig. 16.1**, controls differential lock, causing the wheels on each axle governed by the switch to rotate together. To lock the wheels together, press the upper half of the rocker momentarily (at the red LED). To unlock the wheels, press the upper half of the rocker again.

IMPORTANT: The differential lock rocker switch is guarded to prevent unintentional switch activation. If the LED in the switch begins to blink during normal operation, when the switch has not been activated, this indicates an error condition. Bring the vehicle to an authorized Freightliner service facility as soon as possible.

When the differential lock switch is pressed, three responses are possible: a normal response, a slow response, and an abnormal response.

Normal Response: The LED in the switch blinks until the axle has responded to the request to lock the wheels. At this point, the LED comes on steady and stays illuminated. In normal operation, the wheels may lock so quickly that the blinking of the switch is barely noticeable.

If operation of the switch is not possible for any reason (ignition is turned off, vehicle is moving faster than 25 mph, etc.), the LED will stop blinking and turn off.

Slow Response: If operation of the switch is slowed for any reason (vehicle moving too fast, low air pressure, etc.), the switch will continue to blink until the wheels are able to lock. As in the normal response, the LED comes on steady and stays illuminated once the wheels have locked.

NOTE: If the vehicle is moving too fast, let up slightly on the accelerator. As the vehicle slows, the wheels will lock.

Abnormal Response: If the LED blinks for more than 30 seconds, the lock mechanism may not be fully engaged/disengaged. Bring the vehicle to an authorized Freightliner service facility for testing.

Differential Lock Operation

WARNING

Locking the wheels when the vehicle is traveling down steep grades or when the wheels are slipping could damage the differential and/or lead to loss of vehicle control, causing personal injury and property damage.

Lock the wheels only when the vehicle is standing still or moving at very low speed, less than 5 mph (8 km/h). Never lock the wheels when the vehicle is traveling down steep grades or when the wheels are slipping.

NOTE: On some vehicles, the differential lock system is connected through the low speed range of the transmission. If this system is used, the transmission must be in the low speed range for the wheels to fully lock.

WARNING

A vehicle with locked wheels can still slip sideways, causing possible loss of vehicle control, personal injury, and property damage.

Be especially careful when driving under slippery conditions with the wheels locked. Though forward traction is improved, the vehicle can still slip sideways.

If the vehicle is moving, maintain a constant vehicle speed when the differential lock is turned on. Briefly let up on the accelerator to relieve torque on the gearing, allowing the wheels to lock completely. When the wheels are fully locked, the turning radius will increase because the vehicle understeers. See [Fig. 16.2](#). Drive cautiously and do not exceed 25 mph (40 km/h).

To disengage differential lock after leaving poor road conditions, operate the differential lock switch as discussed above while maintaining vehicle speed. Let up momentarily on the accelerator to allow the wheels to fully unlock, then resume driving at normal speed.

NOTE: If the differential lock system is connected with the transmission in its low speed range, shifting out of the low speed range will also disengage the differential lock function. The switch will blink until the wheels unlock, and then go out.

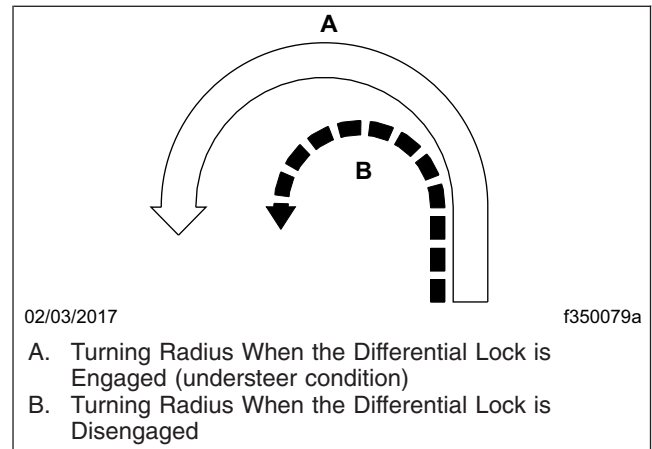

Fig. 16.2, Turning Radii

Tandem Drive Axles With Interaxle Lock

NOTICE

The interaxle lock should not be engaged on a vehicle with obviously spinning wheels. Engagement at high speed or power can damage the axle(s).

Meritor has an interaxle lock (axle lock, interaxle differential lockout) feature that is standard on all dual-drive (tandem-drive) vehicles. Interaxle lock is recommended for use under adverse road conditions where greater traction is needed. See the axle manufacturer's manual provided with the vehicle for more information.

The interaxle lock switch, shown in [Fig. 16.3](#), allows the driver to lock both rear axles together. The red interaxle warning light illuminates on the dash message center when interaxle lock is engaged.

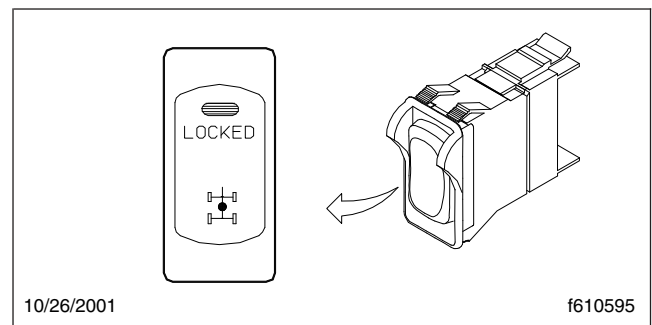

Fig. 16.3, Interaxle Lock Switch

Drive Axles

When the interaxle lock is not engaged, there is differential action between the two axles. The differential compensates for different wheel speeds and variations in tire size. Keep the interaxle lock disengaged when driving on roads where traction is good.

When the interaxle lock is engaged, the differential action between the two axles is locked. Both drive axles now share the power. Both axles, and both sets of wheels, turn together at the same speed. The interaxle lock should be used when the vehicle encounters poor traction conditions; however, it also increases drivetrain and tire wear and should be used only when improved traction is required.

Interaxle Lock Switch

A two-position guarded rocker switch, shown in [Fig. 16.3](#), controls interaxle lock, causing both axle shafts to rotate together. To lock the axles together, press the upper half of the rocker momentarily (at the red LED). To turn off interaxle lock, press the lower half of the rocker (at the double-axle icon).

IMPORTANT: The interaxle lock rocker switch is guarded to prevent unintentional switch activation. This switch does not have a diagnostic blink function when inactive.

When the interaxle lock switch is pressed, three responses are possible: a normal response, a slow response, and an abnormal response.

Normal Response: The LED in the switch blinks until the interaxle lock is engaged. At this point, the LED comes on steady and stays illuminated. In normal operation, the interaxle may lock so quickly that the blinking of the switch is barely noticeable.

If operation of the switch is not possible for any reason (ignition is turned off, vehicle is moving too fast, etc.), the LED will stop blinking and turn off.

Slow Response: If operation of the switch is slowed for any reason (by cold weather, low air pressure, etc.), the switch will continue to blink until the axles lock together, or for a maximum of 10 seconds. As in the normal response, the LED comes on steady and stays illuminated.

Abnormal Response: If the LED blinks for more than 30 seconds, the lock mechanism may not be fully engaged/disengaged. Bring the vehicle to an authorized Freightliner service facility for testing.

Interaxle Lock Operation

To engage interaxle lock and achieve maximum pulling power in slippery or hazardous road conditions, operate the interaxle lock switch as discussed above, while maintaining vehicle speed. Let up momentarily on the accelerator until the axle lock engages. Proceed over poor road conditions with caution. Do not wait until traction is lost and the tires are spinning before engaging the interaxle lock.

NOTICE

Do not turn on the interaxle lock switch when the tires are slipping. Do not continuously operate the vehicle with the interaxle lock engaged during good road conditions. To do so could result in damage to the axle gearing and excessive tire wear.

To disengage the interaxle lock after leaving poor road conditions, operate the interaxle lock switch as discussed above while maintaining vehicle speed. Let up momentarily on the accelerator to allow the axles to fully unlock, then resume driving at normal speed.

Axle Shift

NOTICE

To prevent transmission and axle damage, make sure the automatic transmission is in high range when performing an axle shift with the vehicle moving.

Axle shift is a function installed on vehicles with two-speed axles to allow the use of the low speed range when greater traction and maximum pulling power is needed at low engine speed (rpm).

Under normal operating conditions, the vehicle is operated using the high-speed gear ratios of the axle. Under extreme weather or off-road conditions, at low speed and rpm and/or to pull heavy loads, the vehicle must be operated using the low-speed, or reduction, gear ratios of the axle.

Axle Shift Switch

The axle shift switch is a two-position guarded rocker switch installed on vehicles with two-speed axles. See [Fig. 16.4](#).

To shift the axle from low speed to high speed, press the upper half of the rocker momentarily (at the

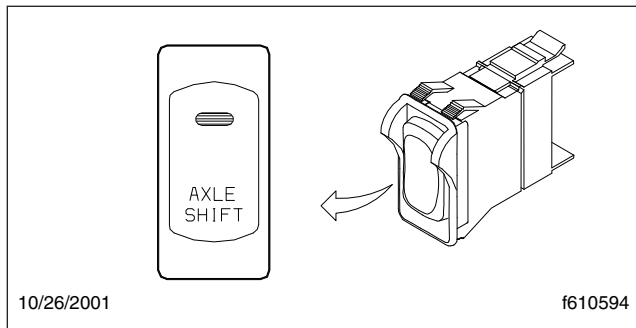

Fig. 16.4, Axle Shift Switch

LED). To turn the axle shift off (switch from high speed back to low speed), press the upper half of the rocker again. When the axle has shifted speed, the LED turns off.

When the panel lights are on, the AXLE SHIFT legend is backlit in green.

IMPORTANT: The axle shift rocker switch is guarded to prevent unintentional switch activation. If the LED in the switch begins to blink during normal operation, when the switch has not been activated, this indicates an error condition. Bring the vehicle to an authorized Freightliner service facility as soon as possible.

When the axle shift switch is pressed, three responses are possible: a normal response, a slow response, and an abnormal response.

Normal Response: The LED in the switch blinks until the axle shifts speed. At this point, the LED comes on steady and stays illuminated. In normal operation, the axle may shift so quickly that the blinking of the switch is barely noticeable.

If operation of the switch is not possible for any reason (interaxle lock is on, ignition is turned off, etc.), the LED will stop blinking and turn off.

Slow Response: If operation of the switch is slowed for any reason (by cold weather, low air pressure, etc.), the switch will continue to blink until the axle shifts. As in the normal response, the LED comes on steady and stays illuminated.

Abnormal Response: If the LED blinks for more than 30 seconds, the axle shift function/mechanism may not be operating correctly. Bring the vehicle to an authorized Freightliner service facility for testing.

Axle Switch Interlock

NOTE: On vehicles with tandem drive axles, there is an interlock that prevents an axle from shifting speed whenever the interaxle lock is on.

If the axle shift switch is pressed when the interaxle lock is on, the axle shift will not be completed. The LED does the following:

- If the LED is off, the LED comes on briefly and turns off again.
- If the LED is on, it stays on.

To complete the axle shift, turn off the interaxle lock and press the axle shift switch again. If still needed, the interaxle lock can then be reactivated.

Driver-Controlled Differential Lock (DCDL)

The driver-controlled differential lock (DCDL) feature (side-to-side wheel lock, traction control, or traction equalizer) is available on vehicles with single- or tandem-drive axles.

The DCDL provides maximum traction for slippery conditions by forcing the wheels on each drive axle governed by the switch to rotate together. When the DCDL is engaged, the clutch collar completely locks the differential case, gearing, and axle shafts together, maximizing the traction of both wheels. Use the DCDL if the interaxle lock does not provide sufficient traction.

A status screen showing engaged locks is found in the vehicle operations menus on the driver display. See [Fig. 16.5](#).

Differential Lock Switch

Each differential lock is controlled by a switch on the dash. See [Fig. 16.6](#).

DCDL Operation



Locking the wheels when the vehicle is traveling down steep grades or when the wheels are slipping could damage the differential and/or lead to loss of vehicle control, causing personal injury and property damage.

Drive Axles

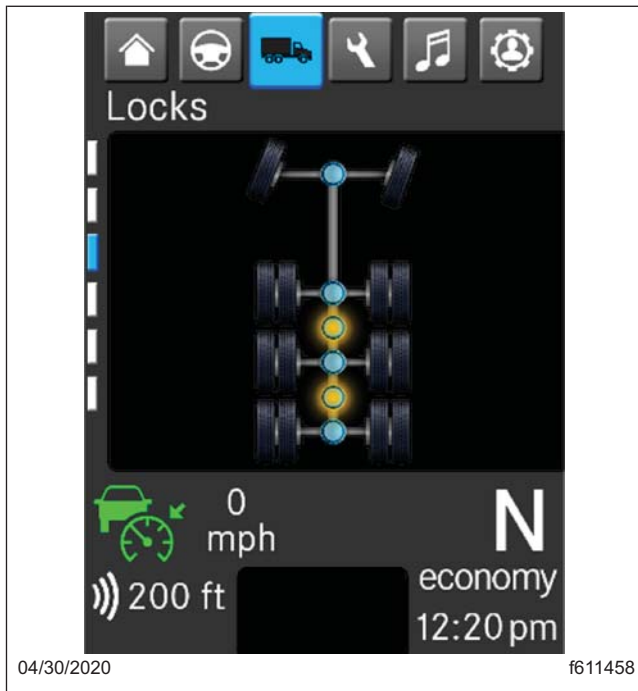

Fig. 16.5, Interaxle and Differential Locks Status Screen

NOTICE

Engage the DCDL only when the vehicle is stopped or moving at less than 5 mph (8 km/h). Engaging the DCDL at speeds above 5 mph (8 km/h) can cause internal axle damage.

NOTE: On some vehicles, the differential lock system is connected through the low speed range of the transmission. If this system is used, the transmission must be in the low speed range for the wheels to fully lock. In addition, shifting out of low speed range will also disengage the differential lock.

NOTE: If the DCDL is engaged when the engine is shut down, the DCDL will disengage.

1. With the engine running, press the upper half of the differential lock switch to engage the DCDL.
2. If the vehicle is moving, briefly let up on the accelerator to relieve torque on the gearing, allowing the differential to fully lock. An indicator light on the differential lock switch illuminates when the lock is engaged. Depending on the vehicle configuration, a buzzer may also sound.

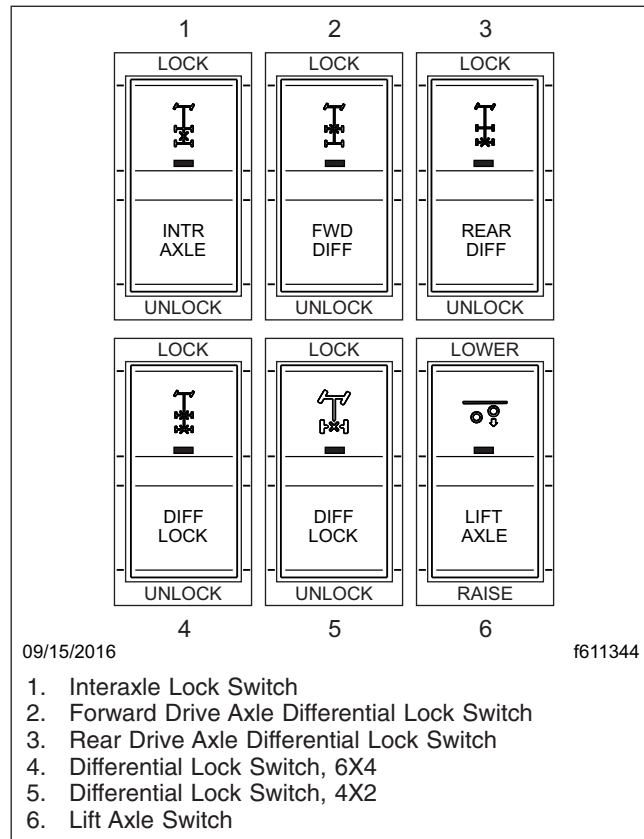

09/15/2016

f611344

1. Interaxle Lock Switch
2. Forward Drive Axle Differential Lock Switch
3. Rear Drive Axle Differential Lock Switch
4. Differential Lock Switch, 6X4
5. Differential Lock Switch, 4X2
6. Lift Axle Switch

Fig. 16.6, Axle Switches

WARNING

Be especially careful when driving under slippery conditions with the differential locked. Though forward traction is improved, the vehicle can still slip sideways, causing possible loss of vehicle control, personal injury, and property damage.

3. Drive cautiously and do not exceed 25 mph (40 km/h). When the differential is fully locked, the turning radius will increase because the vehicle understeers. See Fig. 16.7.
4. Press the lower half of the differential lock switch to disengage the DCDL after leaving poor road conditions.
5. If the vehicle is moving, briefly let up on the accelerator to allow the wheels to fully unlock, then resume driving at normal speed.

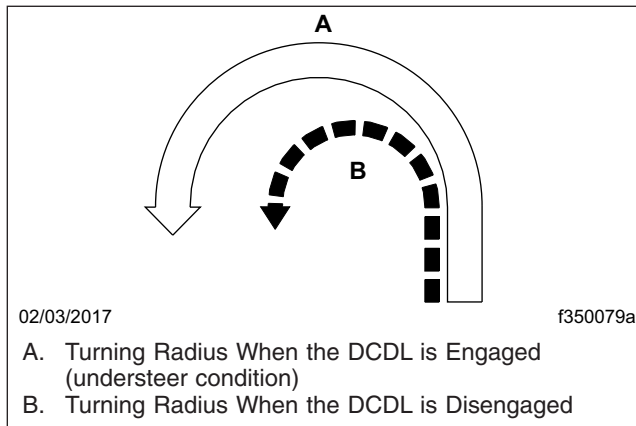

Fig. 16.7, Turning Radii

Single Drive Axles with Traction Equalizer

Some single drive axles are equipped with a traction equalizer that is a load-sensing, self-actuating feature. A traction equalizer provides normal differential action where traction is good. When one wheel begins to spin faster than the other, clutch plates in the differential housing automatically engage, delivering power to both wheels. There is no operator control with this feature.

NOTICE

Tire sizes on both rear wheels should be the same on axles equipped with a traction equalizer. If not, excessive wear may occur in the traction equalizer.

Interaxle Lock, Tandem Axles

The interaxle lock (axle lock, interaxle differential lockout) feature causes the drive axle shafts to rotate together, and is recommended for use under adverse road conditions where greater traction is needed.

When engaged, the interaxle lock essentially makes the driveshaft a solid connection between the drive axles. Power entering the forward axle is transmitted straight through to the rearmost axle(s). Driveline torque is now delivered equally and the drive axles, and wheels, turn together at the same speed. The interaxle lock increases drivetrain and tire wear and should be used only when improved traction is required.

A status screen showing engaged locks is found in the vehicle operations menus on the driver display. See [Fig. 16.5](#).

Interaxle Lock Switch

The interaxle lock switch, shown in [Fig. 16.6](#), allows the driver to lock the drive axles together.

Interaxle Lock Operation

NOTICE

The interaxle lock should not be engaged on a vehicle with obviously spinning wheels. Engagement at high speed or power can damage the axle(s).

NOTE: If the interaxle lock is engaged when the engine is turned off, the interaxle lock will disengage.

1. With the engine running, press the upper half of the interaxle lock switch to engage the interaxle lock. Do not wait until traction is lost and the tires are spinning before engaging the interaxle lock.
2. If the vehicle is moving, briefly let up on the accelerator until the interaxle lock engages. An indicator light on the interaxle lock switch illuminates when the lock is engaged. Depending on the vehicle configuration, a buzzer may also sound.

NOTICE

Do not operate the vehicle continuously with the interaxle locked during extended good road conditions. To do so could result in damage to the axle gearing and excessive driveline and tire wear.

3. Proceed over poor road conditions with caution.
4. Press the lower half of the interaxle lock switch to disengage the interaxle lock after leaving poor road conditions.
5. If the vehicle is moving, briefly let up on the accelerator to allow the interaxle lock to disengage, then resume driving at normal speed. Once the interaxle lock disengages, the indicator light will go off.

Fifth Wheels and Trailer Couplings

Fifth Wheel Lubrication	17.1
Fifth Wheel Coupling	17.1
Fifth Wheel Uncoupling	17.8
Fifth Wheel Slide	17.10
Trailer Couplings	17.12

Fifth Wheels and Trailer Couplings

Fifth Wheel Lubrication

WARNING

A standard fifth wheel plate must be kept lubricated to prevent binding between the tractor and trailer. A binding fifth wheel could cause erratic steering and loss of vehicle control, possibly resulting in personal injury or death.

The standard fifth wheel plate must be kept well lubricated with chassis grease to prevent friction and binding between the tractor fifth wheel plate and the trailer.

For lubrication instructions, see **Group 31** of the *M2 Plus Maintenance Manual*.

For a low-lube fifth wheel plate, inspect the condition of the low-lube pads. There should be no damaged or missing pieces. Slight puckering at the outside edges is normal.

For no-lube fifth wheel plates, inspect the condition of the no-lube pads. If any of the following conditions are present, replace the lube plates.

- Plates severely chipped, cracked, gouged, or bent.
- More than 20% of the lube plate coating missing from one or both plates due to normal wear.
- A straight edge laid across the lube plate contacts parts of the surrounding fifth wheel as shown [Fig. 17.1](#).

Fifth Wheel Coupling

WARNING

Do not use any fifth wheel that fails to operate properly. Doing so may cause loss of vehicle control, possibly resulting in severe personal injury or death.

Fifth wheel coupling is activated with the lock control handle located on either the right or left side of the fifth wheel. Coupling has successfully occurred when the kingpin is in the fifth wheel jaws and the control handle has moved to the locked position.

Due to the number of options available, your vehicle may be equipped with a fifth wheel not described in this manual. In this situation, please reference the vendor literature on the fifth wheel installed.

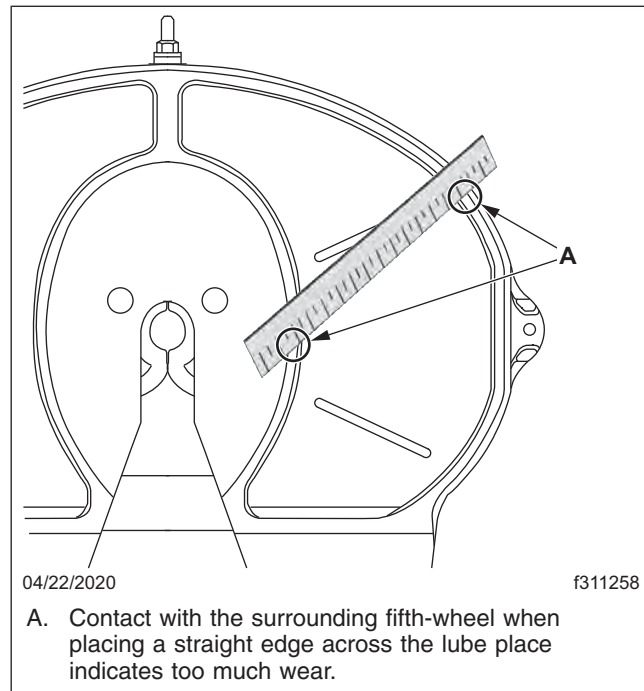

Fig. 17.1, No-Lube Plate Wear Inspection

NOTICE

Some fifth wheels may be mounted on sliding rails. Before attempting to couple a trailer to a sliding fifth wheel, the slide feature must be locked to prevent the top plate from sliding rapidly forward or rearward, causing damage to the fifth wheel or kingpin.

Trailer Auxiliary Switch

The trailer auxiliary switch energizes an optional circuit that allows the trailer electrical system to draw power.

Press the top of the switch to activate the trailer auxiliary function. Press the bottom of the switch to turn trailer auxiliary function off. See [Fig. 17.2](#).

Fontaine Fifth Wheel Coupling

1. Chock the front and rear of the trailer tires to prevent the trailer from moving.
2. If equipped with a **standard fifth wheel**, check the surface of the fifth wheel for a liberal coating of grease.

If equipped with a **no- or low-lube fifth wheel**, inspect the conditions of the pads.

Fifth Wheels and Trailer Couplings

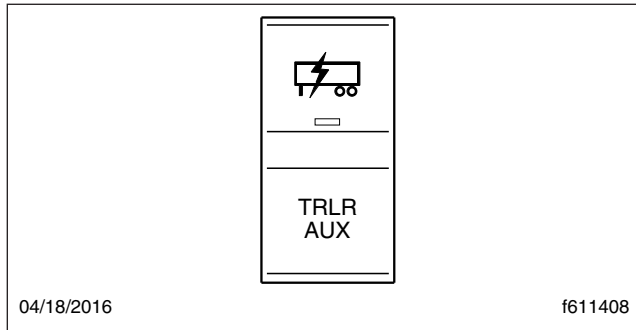

Fig. 17.2, Trailer Auxiliary Switch

3. Ensure the fifth wheel jaws are fully open and the lock control handle is fully extended as shown in Fig. 17.3.
4. If equipped with a **standard fifth wheel**, inspect the trailer kingpin plate to verify it is large enough to completely cover the fifth wheel and is properly greased.

If equipped with a **no- or low-lube fifth wheel**, ensure the leading edge of the trailer skid plate is free of sharp edges.

5. Make sure the fifth wheel top plate is tilted so the ramps are as low as possible.
6. Position the tractor so the kingpin is in a position to enter the throat of the fifth wheel as shown in Fig. 17.4.

⚠ WARNING

When coupling, always inflate the tractor suspension air bags prior to coupling.

Inflating the tractor suspension air bags while positioned underneath the trailer may result in damage to and incorrect coupling of the fifth wheel, possibly resulting in serious personal injury or death.

NOTICE

Attempting to couple at the wrong height may cause improper coupling, which could result in damage to the fifth wheel or kingpin.

7. Adjust the trailer height if required.

For a **standard fifth wheel**, the trailer should contact the fifth wheel at the top of the approach ramps as shown in Fig. 17.5.

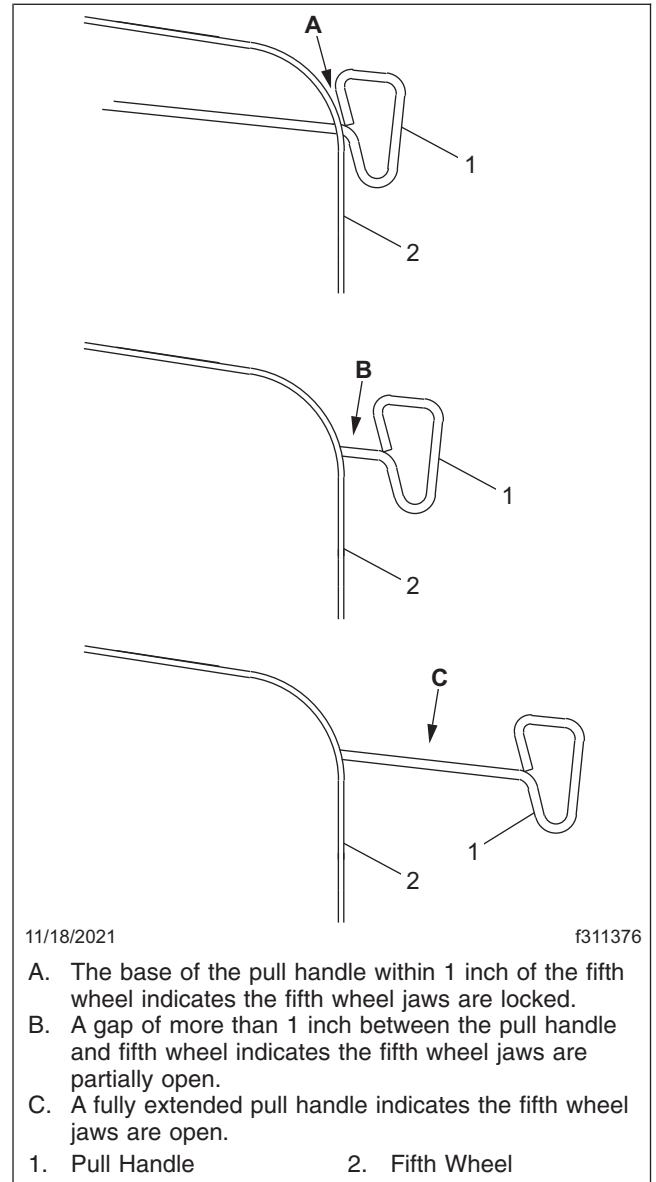

11/18/2021

f311376

- A. The base of the pull handle within 1 inch of the fifth wheel indicates the fifth wheel jaws are locked.
- B. A gap of more than 1 inch between the pull handle and fifth wheel indicates the fifth wheel jaws are partially open.
- C. A fully extended pull handle indicates the fifth wheel jaws are open.

1. Pull Handle
2. Fifth Wheel

Fig. 17.3, Fontaine Fifth Wheel Lock Handle Positions

For a **no- or low-lube fifth wheel**, the fifth wheel must slide freely under the trailer; the trailer should contact the fifth wheel at the pivot point shown in Fig. 17.6.

8. With the fifth wheel opening aligned with the trailer kingpin, back the tractor slowly toward the trailer. To prevent the trailer from slamming into the kingpin, after sliding under the trailer, **stop**. Then resume backing up slowly until the fifth wheel locks.
9. Apply the tractor parking brakes.

Fifth Wheels and Trailer Couplings

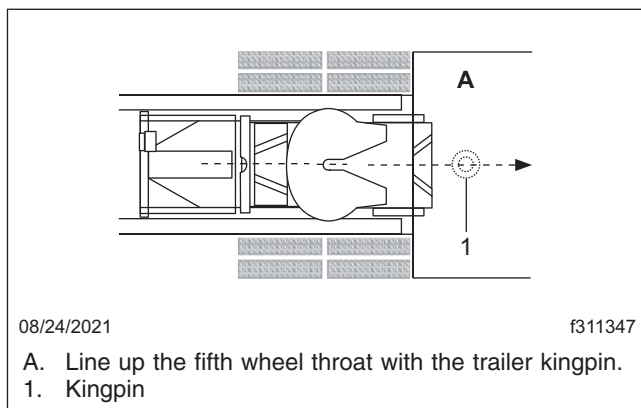

Fig. 17.4, Positioning the Tractor

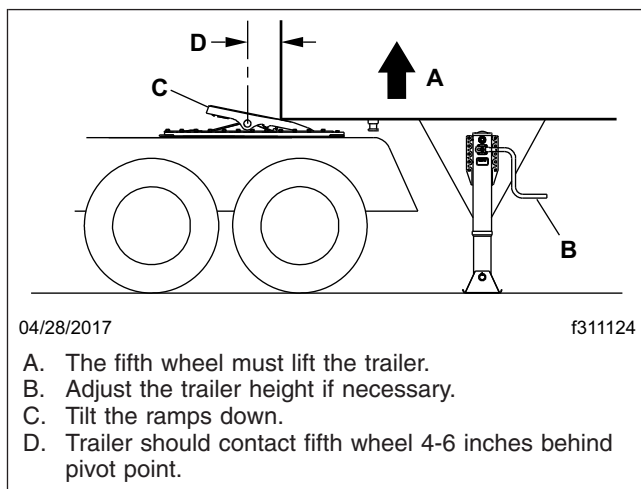

Fig. 17.5, Trailer Connection Point, Standard Fifth Wheel

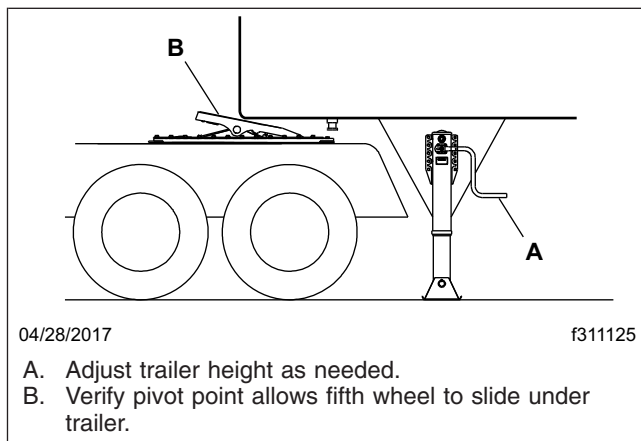

Fig. 17.6, Trailer Connection Point for No- and Low-Lube Fifth Wheels

⚠ WARNING

A visual inspection is required by law.

Some improper couplings can pass a pull test. Sound is not reliable.

Get out of the cab and look.

Incorrect coupling could cause the trailer to disconnect, possibly resulting in serious personal injury or death.

10. Perform a coupling inspection.
 - 10.1 Verify there is no gap between the bottom of the trailer and the fifth wheel as shown in [Fig. 17.7](#).
 - 10.2 Make sure the jaw and wedge of the fifth wheel are locked in place behind the kingpin as shown in [Fig. 17.7](#).

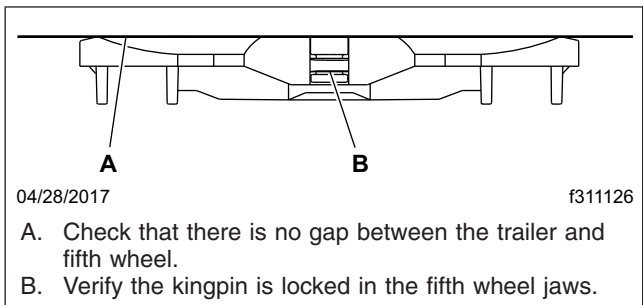

Fig. 17.7, Coupling Inspection View

- 10.3 Check that the lock control handle is fully retracted as shown in [Fig. 17.3](#); the gap between the back of the pull handle and the skirt of the fifth wheel should be *less than* one inch as shown in [Fig. 17.8](#).

⚠ WARNING

Incorrect fifth wheel locking could cause the trailer to disconnect, possibly resulting in serious personal injury or death.

11. Release the tractor parking brakes.

Test for kingpin lockup by slowly inching the tractor forward, pulling on the trailer against the chocks.
12. After lockup is completed and verified, connect the tractor-to-trailer air system lines and the electrical cable to the trailer. Take care to prevent

Fifth Wheels and Trailer Couplings

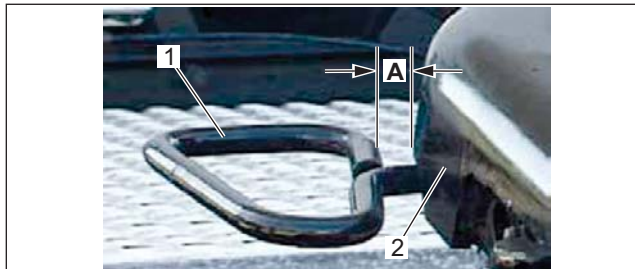

08/23/2021

f311363

- A. Make sure there is less than a one inch gap between the back of the pull hand and the fifth wheel skirt.
1. Pull Handle
 2. Skirt of Fifth Wheel

Fig. 17.8, Fontaine Fifth Wheel Handle Retracted

dirt or foreign material from entering the air system lines.

NOTICE

Always make sure the connection hanger keeps the trailer air hoses and electrical cables positioned so that they do not rub on anything. Rubbing may wear through hoses or cables, resulting in air leaks, or exposed or broken wires, potentially affecting trailer brake or electrical systems.

13. Charge the air brake system with air, checking that the air connections do not leak.
14. Fully retract the landing gear legs and secure the crank handle.
15. Remove the chocks.

Holland Fifth Wheels Coupling

1. Chock the front and rear of the trailer tires to prevent the trailer from moving.
2. If equipped with a **standard fifth wheel**, check the surface of the fifth wheel for a liberal coating of grease.
If equipped with a **no- or low-lube fifth wheel plate** ensure there are no sharp edges, nuts, bolts, gouges, or large holes along the leading edge of the trailer or the path of the fifth wheel, as shown in [Fig. 17.9](#), and that any upper coupler residual grease is free of coarse grit.
3. Ensure the fifth wheel jaw is fully open and the release handle is in the unlocked position.

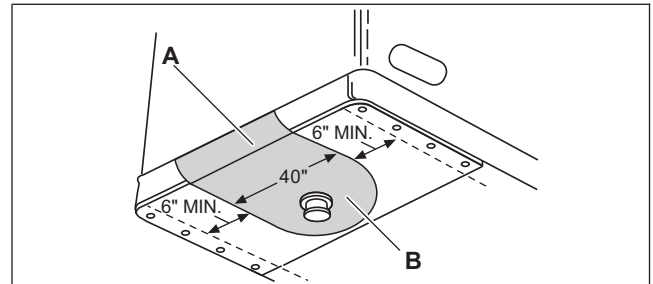

08/24/2021

f311356

- A. Keep the direct path of fifth wheel and six inches to either side free of large holes and gouges.
- B. Keep bolts and nuts clear of the bolster plate.

Fig. 17.9, Path of a Fifth Wheel

- 3.1 To unlock a **Holland FW35/31** fifth wheel, pull out the release handle as shown in [Fig. 17.10](#).

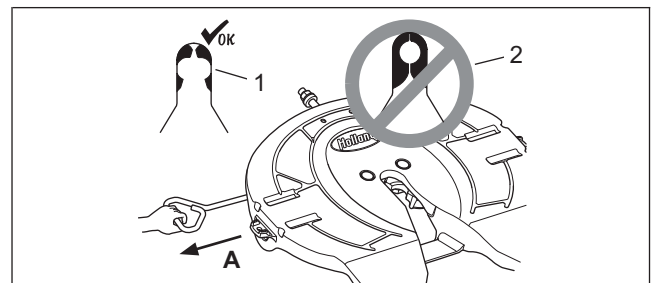

08/25/2021

f311346

- A. Pull the release handle to open the lock.
1. Lock Open
 2. Lock Closed

Fig. 17.10, FW35 Holland Locks Open and Closed

- 3.2 To unlock a **Holland FWAL**:
 - Slide the release handle forward to move the front notch on the locking plate clear of the bracket.
 - Pull the release handle completely out.
 - Slide the release handle forward again to hook the rear notch on the locking plate onto the bracket as shown in [Fig. 17.11](#).
4. Make sure the fifth wheel top plate is tilted rearwards with the ramps down and resting on the tilt stops.
5. Position the tractor so that the center of the fifth wheel is in line with the trailer kingpin as shown

Fifth Wheels and Trailer Couplings

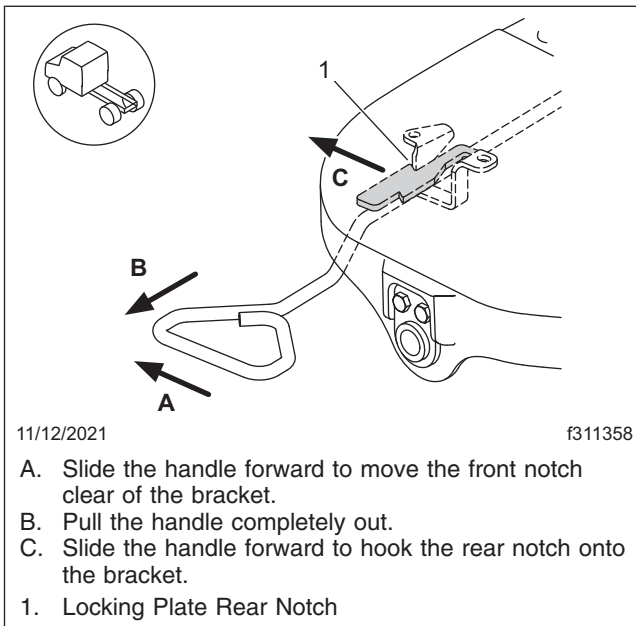

Fig. 17.11, Unlocking a Holland FWAL

in [Fig. 17.4](#). The kingpin should be in a position to enter the throat of the locking mechanism.

NOTICE

Attempting to couple at the wrong height may cause improper coupling, which could result in damage to the fifth wheel or kingpin.

6. Adjust the trailer height if required.

For a **standard fifth wheel plate**, the trailer should contact the fifth wheel approximately 4 to 8 inches (10 to 20 cm) behind the fifth wheel pivot as shown in [Fig. 17.5](#).

For a **no- or low-lube fifth wheel plate**, the fifth wheel must slide freely under the trailer; the trailer should contact the fifth wheel at the pivot point shown in [Fig. 17.6](#).

7. With the fifth wheel lock opening aligned with the trailer kingpin, back the tractor slowly toward the trailer. After sliding under the trailer, **stop** to prevent from hitting the kingpin, then resume backing up slowly until the fifth wheel locks.

On a standard fifth wheel, the fifth wheel must lift the trailer.

On a no- or low-lube fifth wheel, do **not** lift the trailer. Lifting the trailer with a no- or low-lube fifth wheel may damage the fifth wheel plate.

8. Apply the tractor parking brakes.

WARNING

A visual inspection is required by law.

Some improper couplings can pass a pull test. Sound is not reliable.

Get out of the cab and look.

Incorrect coupling could cause the trailer to disconnect, possibly resulting in serious personal injury or death.

9. Perform a coupling inspection.

9.1 Verifying a Holland FW35/31 fifth wheel is locked:

- Verify that there is no gap between the bottom of the trailer and the fifth wheel as shown in [Fig. 17.12](#).

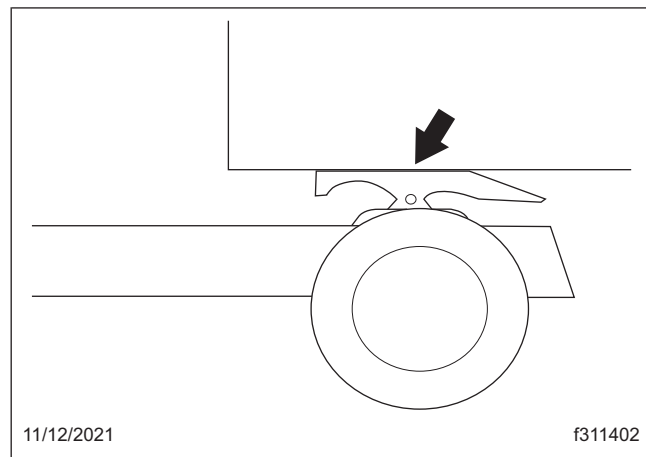

Fig. 17.12, No Gap Between Fifth Wheel and Trailer

- Verify that the kingpin is securely locked as shown in [Fig. 17.13](#).
- Verify that the nut and washer are snug against the fifth wheel as shown in [Fig. 17.14](#).

9.2 Verifying a Holland FWAL is locked:

- Verify that there is no gap between the bottom of the trailer and the fifth wheel as shown in [Fig. 17.12](#).
- Verify that the kingpin is securely locked as shown in [Fig. 17.15](#).
- Verify that the handle is fully retracted as shown in [Fig. 17.16](#).

Fifth Wheels and Trailer Couplings

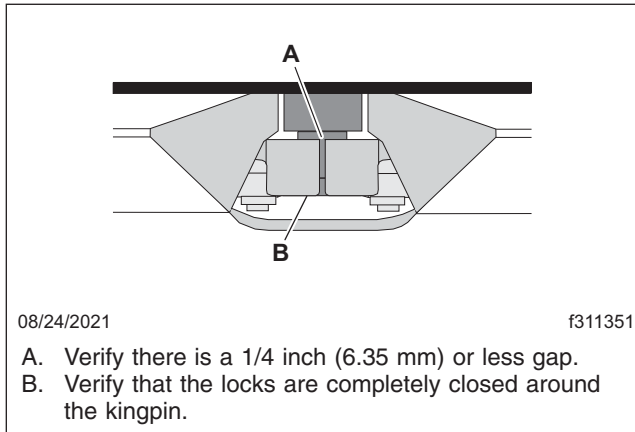

Fig. 17.13, Kingpin Locked in Holland FW35/31 Fifth Wheel Jaws

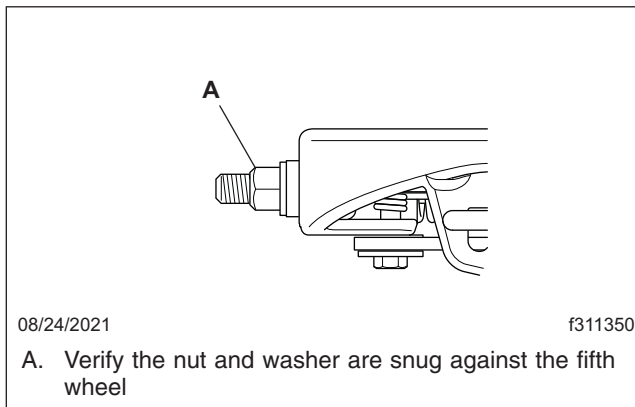

Fig. 17.14, Nut and Washer Snug Against Locked Holland FW35/31

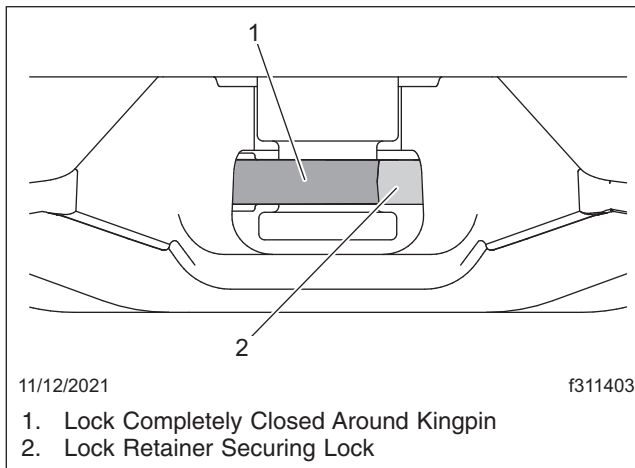

Fig. 17.15, Holland FW17 or FWAL Lock Closed Around Kingpin

10. Release the tractor parking brakes.

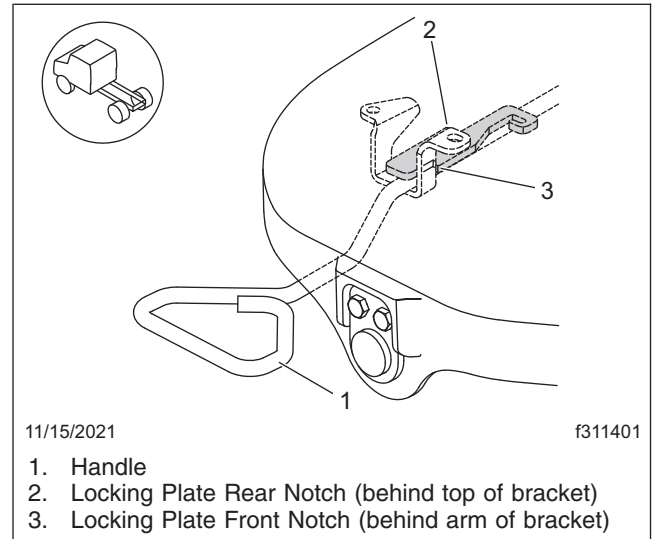

Fig. 17.16, Holland FWAL Handle Fully Retracted

Test for kingpin lockup by slowly inching the tractor forward, pulling the trailer against the chocks.

11. After lockup is completed, connect the tractor-to-trailer air system lines and the electrical cable to the trailer. Take care to prevent dirt or foreign material from entering the air system lines.

NOTICE

Always make sure the connection hanger keeps the trailer air hoses and electrical cables positioned so that they do not rub on anything. Rubbing may wear through hoses or cables, resulting in air leaks, or exposed or broken wires, potentially affecting trailer brake or electrical systems.

12. Charge the air brake system with air, checking that the air connections do not leak.

WARNING

Incorrect fifth wheel lock adjustment could cause the trailer to disconnect, possibly resulting in serious personal injury or death.

13. With the trailer wheels chocked and the brakes set, check for clearance between the kingpin and the fifth wheel jaws by moving the tractor forward and backward against the locked kingpin. If slack is present, uncouple the trailer and have the fifth

Fifth Wheels and Trailer Couplings

wheel inspected and adjusted by a certified technician.

Jost Fifth Wheel Coupling

1. Chock the front and rear of the trailer tires to prevent the trailer from moving.
2. Tilt the fifth wheel ramps down.
3. Unlock the fifth wheel jaws.

Lift the release handle up into the wide slot and then pull the release handle out while moving it forward as shown in [Fig. 17.17](#). Lock the handle into the open position on the notch provided.

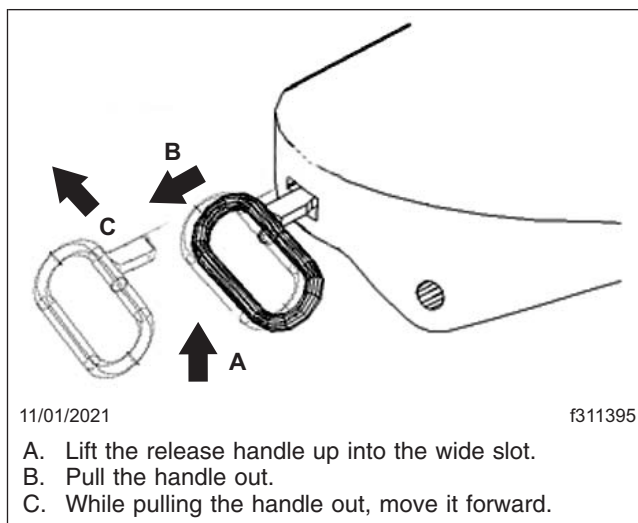

Fig. 17.17, Unlocking the Jost Fifth Wheel

4. Back the vehicle close to the trailer, centering the kingpin on the fifth wheel throat as shown in [Fig. 17.4](#).

NOTICE

Attempting to couple at the wrong height may cause improper coupling, which could result in damage to the fifth wheel or kingpin.

5. Adjust the trailer height (if required).

For a standard fifth wheel plate, the trailer should contact the fifth wheel the top of the approach ramps or approximately 4 to 6 inches (10 to 20 cm) behind the pivot point as shown in [Fig. 17.5](#).

For a low-lube fifth wheel plate, the trailer should contact the fifth wheel at the pivot point

and the fifth wheel must slide freely under the trailer as shown in [Fig. 17.6](#).

6. Back the tractor slowly toward the trailer.

On a **standard fifth wheel**, the fifth wheel must lift the trailer.

On a **no- or low-lube fifth wheel**, do **not** lift the trailer. Lifting the trailer with a no- or low-lube fifth wheel may damage the fifth wheel plate.

After lifting or sliding under the trailer, **stop**. This is to prevent hitting the kingpin too hard. Then resume backing up slowly until the fifth wheel locks.

WARNING

A visual inspection is required by law.

Some improper couplings can pass a pull test. Sound is not reliable.

Get out of the cab and look.

Incorrect coupling could cause the trailer to disconnect, possibly resulting in serious personal injury or death.

7. Apply the tractor parking brake, then perform a physical check for positive kingpin lockup.

Depending on the fifth wheel model, the handle should be fully retracted with the handle inside the narrow slot as shown in [Fig. 17.18](#) or the release handle should abut the casting as shown in [Fig. 17.19](#).

There should be no gap between the trailer and the fifth wheel.

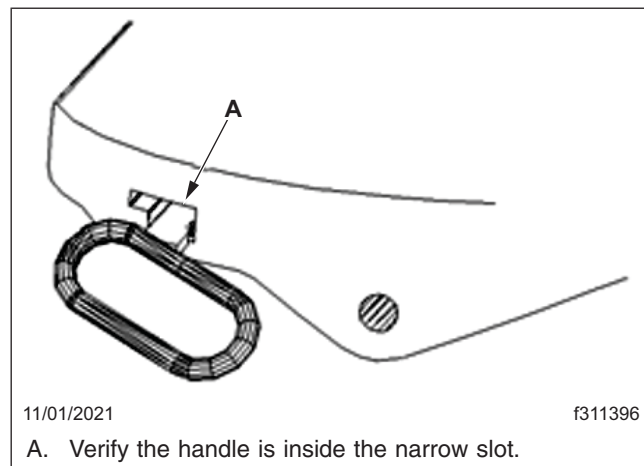

Fig. 17.18, Locked Jost Fifth Wheel

Fifth Wheels and Trailer Couplings

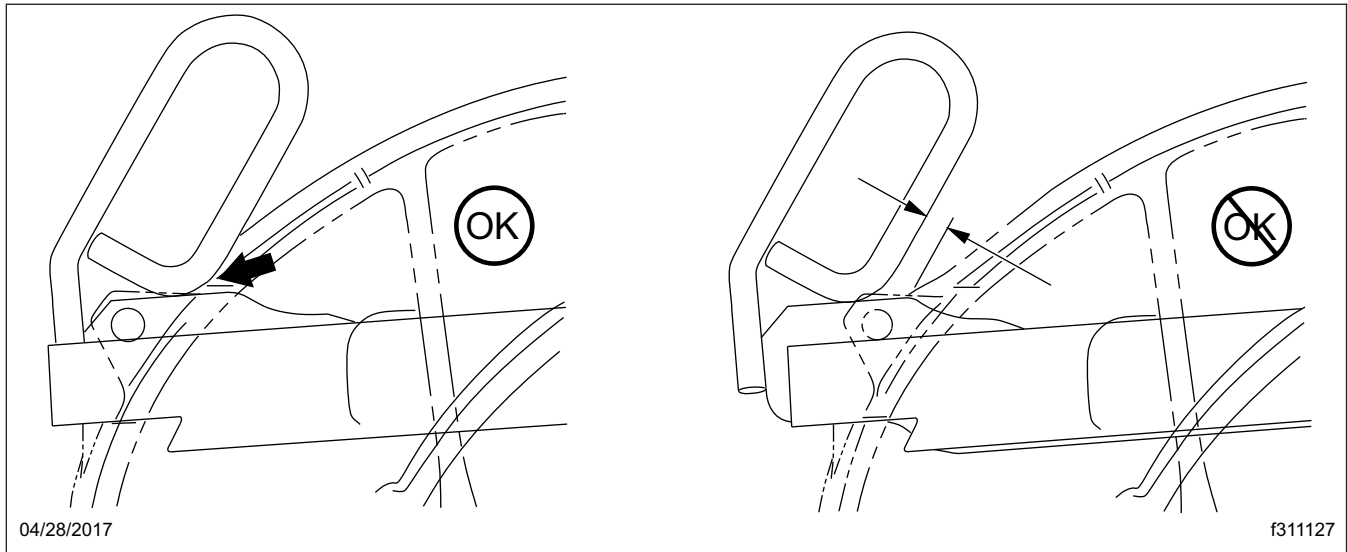

Fig. 17.19, Jost Release Handle Locked

8. Release the tractor parking brakes and test for kingpin lockup by slowly moving the tractor forward, pulling the trailer against the chocks.
9. After lockup is verified, connect the tractor-to-trailer air system lines and the electrical cable to the trailer. Take care to prevent dirt or foreign material from entering the air system lines.

NOTICE

Always make sure the connection hanger keeps the trailer air hoses and electrical cables positioned so that they do not rub on anything. Rubbing may wear through hoses or cables, resulting in air leaks, or exposed or broken wires, potentially affecting trailer brake or electrical systems.

10. Charge the air brake system with air, checking that the air connections do not leak.
11. Fully retract the landing gear legs and secure the crank handle.
12. Remove the chocks.

Fifth Wheel Uncoupling

Manual Uncoupling

1. Slowly back the tractor tightly against the trailer to relieve pressure on the fifth wheel lock.
2. Apply the tractor and trailer parking brakes.

3. Chock the trailer rear wheels.
4. Lower the trailer landing gear until the weight is removed from the fifth wheel.
5. Disconnect the tractor-to-trailer air system lines and electrical cable. Plug the air lines to prevent dirt or foreign material from entering the lines.
6. Verify that both the yellow parking-brake and red trailer-air-supply knobs are out, the tractor and trailer parking brakes are set, and that the trailer is prepared for uncoupling.
7. Release the kingpin locking mechanism following the instructions for each manufacturer below.
 - 7.1 **Fontaine:** Lift the safety latch and pull the lock control handle to the unlocked position as shown in [Fig. 17.3](#).
 - 7.2 **Holland FW35/33:** Pull out the release handle as shown in [Fig. 17.10](#).
 - 7.3 **Holland FWAL:** Slide the handle forward to move the front notch on the locking plate clear of the bracket.
Pull the handle completely out.
Slide the handle forward again to hook the rear notch on the locking plate onto the bracket as shown in [Fig. 17.11](#).
 - 7.4 **Jost:** Depending on the fifth wheel either:
Lift the release handle up into the wide slot and then pull the handle out while moving it forward as shown in [Fig. 17.17](#).

Fifth Wheels and Trailer Couplings

Then lock the handle into the open position on the notch provided.

Or, in the event of a failure in an air release system, pull the handle directly out and hook it open on the notch as shown in **Fig. 17.21**.

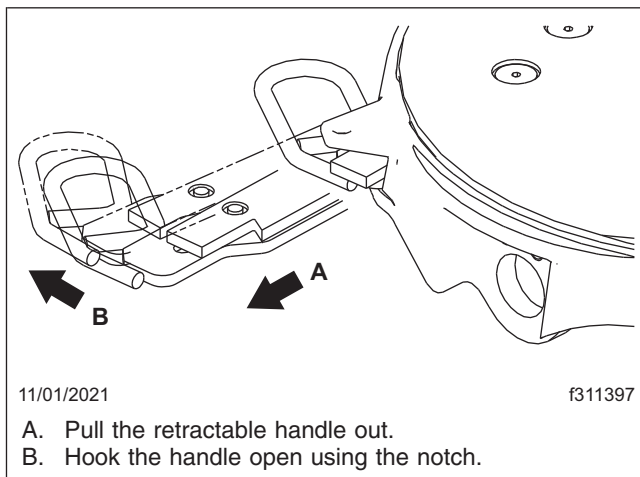

Fig. 17.20, Jost Release Handle Unlocked

8. Release the tractor parking brake then drive forward slowly, allowing the trailer to slide down the fifth wheel and off the ramps.

Air-Actuated Uncoupling

A dash-mounted kingpin release switch (if so equipped) may be used to uncouple the trailer. See **Fig. 17.22**.

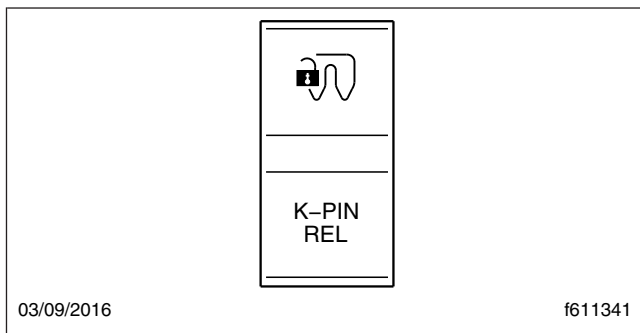

Fig. 17.22, Kingpin Release Switch

NOTE: In the event of an air system failure, air-actuated kingpins can be manually released following the instructions for manual uncoupling. If there is an issue, **Fig. 17.23** should appear on the driver's display screen.



Fig. 17.23, Kingpin Release Not Confirmed Popup, ICUC

WARNING

Once the kingpin release switch has been pushed, the kingpin lock is released. The vehicle **MUST NOT** be driven with the trailer until the trailer has been uncoupled and coupled again. Failure to do so may result in separation of the trailer from the tractor, possibly causing serious personal injury or death.

Preparing the Trailer for Uncoupling

Before using the air valve to unlock a fifth wheel kingpin, prepare the trailer as follows.

1. Slowly back the tractor tightly against the trailer to relieve pressure on the fifth wheel locks.
2. Apply the tractor and trailer parking brakes.
3. Chock the trailer rear wheels.
4. Lower the trailer landing gear until the weight is removed from the fifth wheel.
5. Disconnect the tractor-to-trailer air lines and electrical cable. Plug the air lines to prevent dirt or foreign material from entering the lines.

Air-Activated Kingpin Unlock

NOTE: The kingpin release will not activate if the vehicle is moving, the parking brake is not set, or if the switch is pushed for less than 3 seconds. Unless all of these conditions are met, the trailer will not be uncoupled.

If the kingpin release switch is pressed for less than 3 seconds, **Fig. 17.24** will appear on the driver display. Press the back arrow to dismiss the popup.

Fifth Wheels and Trailer Couplings

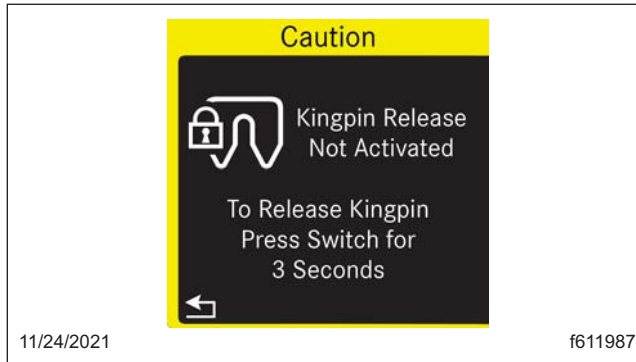

Fig. 17.24, Kingpin Release Not Activated Popup, ICUC

1. Verify that both the yellow parking-brake and red trailer-air supply knobs are out, the tractor and trailer parking brakes are set, and that the trailer is prepared for uncoupling.
2. Push and hold the kingpin release switch, shown in Fig. 17.22, for a minimum of 3 seconds. The system will apply air for 20 to 30 seconds to ensure the kingpin unlocks. When the kingpin is unlocked, a notification is displayed as shown in Fig. 17.25.
3. Release the tractor parking brake.
4. Drive out from under the trailer.



Fig. 17.25, Kingpin Release Alert Screen, ICUC

Fifth Wheel Slide



Adjust the fifth wheel slide correctly. Do not overload any tractor axle by incorrectly loading the trailer.

Incorrect slide adjustment or improper axle loading could cause erratic steering and loss of

vehicle control, possibly resulting in serious personal injury or death.

On sliding fifth wheel assemblies, the fifth-wheel plate is attached to rails that allow forward and rearward movement of the fifth wheel to optimally distribute the load across the axles. Slots are evenly spaced along the slide rails, and retractable wedges are positioned through the slots to hold the fifth wheel in the desired position.

The amount of load distribution on the front steering axle and rear drive axle(s) will have a direct effect on the steering control of the vehicle. Determine the front and rear axle weights by weighing the vehicle on scales designed for this purpose.

The maximum axle weight ratings are shown on the Federal Motor Vehicle Safety Standard (FMVSS) label or Canadian Motor Vehicle Safety Standard (CMVSS) label; see the 'Vehicle Identification' chapter for the location of these labels on your vehicle. The desired load on the axle is no less than 80 percent of the maximum axle weight rating, but in no instances should the axle load exceed the maximum axle weight rating given on the FMVSS or CMVSS label.

Fifth Wheel Slide Control Switch

NOTICE

Do not activate the fifth wheel slide control valve while the vehicle is in motion. To do so could cause damage to the fifth wheel member, the kingpin, the cab or trailer, and ultimately to the drivetrain.

The fifth wheel air slide switch operates an air cylinder that locks and unlocks the slide. See Fig. 17.26.

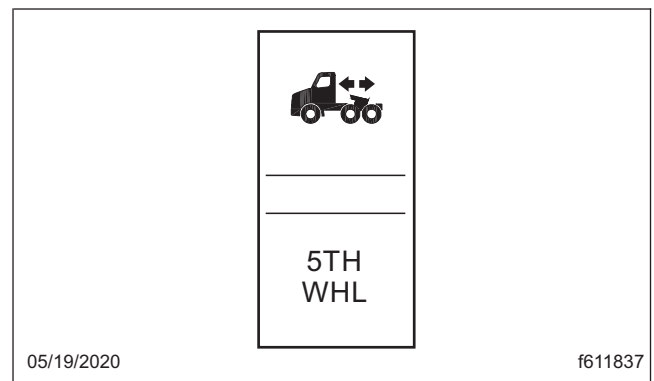

Fig. 17.26, Fifth Wheel Slide Control Switch

Fifth Wheels and Trailer Couplings

Moving the air slide control valve switch to the lock position deactivates the control valve and locks the fifth wheel to the baseplate. Moving the switch to the SLIDE position activates the control valve and unlocks the fifth wheel slide mechanism, allowing changes to the total length of the tractor-trailer and changes to axle loads to comply with varying jurisdictional laws.

Air Slide Operation

1. Set the air-slide switch to SLIDE.

Ensure the locking plungers have released.

For **Fontaine** fifth wheels, see **Fig. 17.27** and **Fig. 17.28** for depictions of the locked and unlocked states.

For **Holland** fifth wheels, locking plungers retract as shown in **Fig. 17.29**.

For **Jost** fifth wheels, the mechanism activates as shown in **Fig. 17.30**.

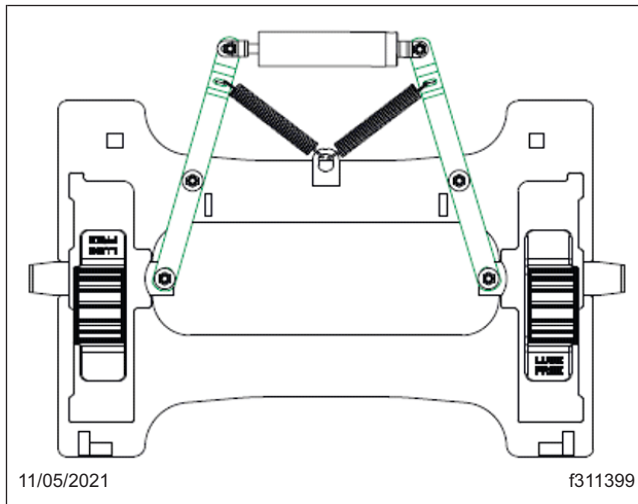

Fig. 17.27, Locked Fontaine Air-Operated Sliding Fifth Wheel

2. Lower the trailer landing gear just enough to remove the weight from the tractor.
3. Pull the red trailer-air-supply knob to set the trailer-parking brakes.
4. Slowly move the tractor forward or backward until the fifth wheel is in the desired location.

NOTE: Ensure the trailer landing gear does not come in contact with the tractor frame or other components, and that the front of the trailer will not come in contact with the rear of the cab or

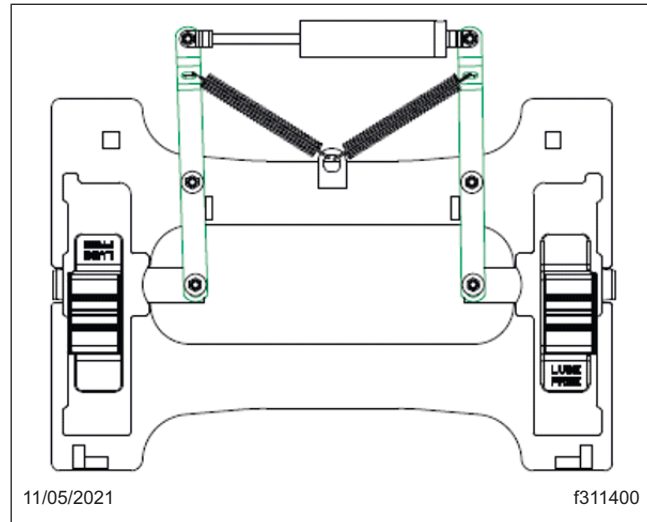

Fig. 17.28, Unlocked Fontaine Air-Operated Sliding Fifth Wheel

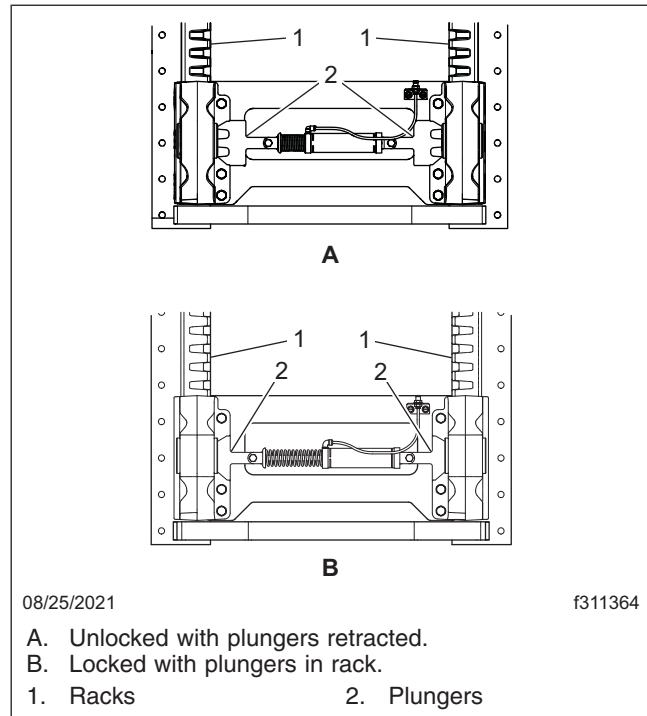

Fig. 17.29, Holland Air-Operated Sliding Fifth Wheel

other components if they extend beyond the rear of the cab.

5. Apply the tractor parking brakes.

Fifth Wheels and Trailer Couplings

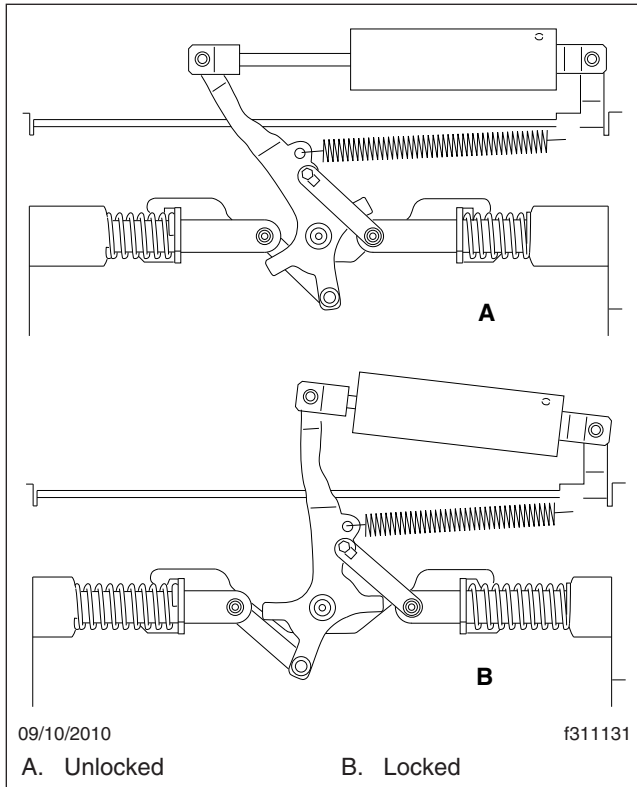

Fig. 17.30, Jost Sliding Fifth Wheel

WARNING

Check that the locking wedges have seated in the slots. Failure to achieve complete lockup may allow disengagement of the tractor from the trailer, possibly resulting in serious personal injury or death.

6. Set the air-slide switch to LOCK. Visually inspect the locking wedges or plungers to make sure that they are fully inserted in the slide rail slots. The fifth wheel may need to be moved slightly to enable the locking wedges to fully lock.

Further verify that the plungers have engaged by tugging the tractor forward while the trailer brakes are locked and the wheels are chocked.

Trailer Couplings

Holland Trailer Couplings

IMPORTANT: Refer to the Holland web site (www.safholland.us/us/en/) for additional information.

The Holland trailer coupling is designed for use with trailers having a maximum gross weight of 30,000 lb. (13,610 kg) for Holland PH-30RP41 and PH-30RP51. It is a rigid-type pintle hook, used only on tractor applications, and is fastened to the rear closing crossmember of the vehicle. It is a non-air-adjusted coupling. See [Fig. 17.31](#) and [Fig. 17.32](#).

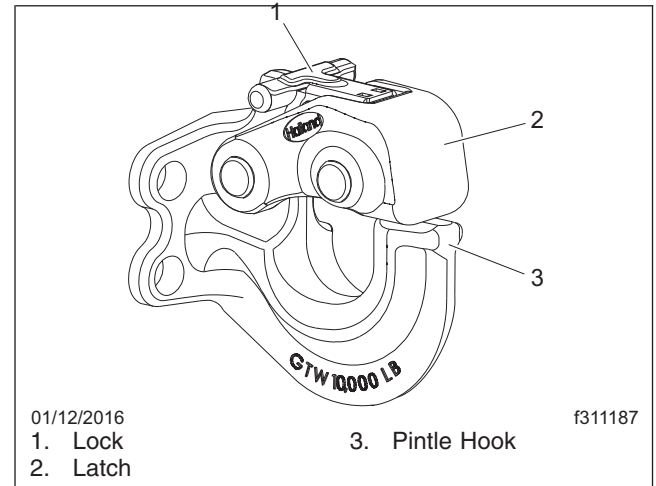

Fig. 17.31, Holland Trailer Coupling with FastLatch

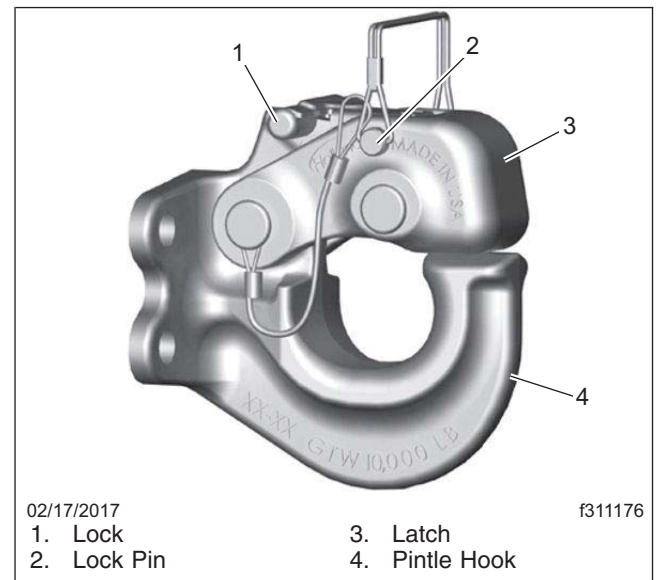

Fig. 17.32, Holland Trailer Coupling with Lock Pin

Holland Coupling Trailer Hookup

1. Chock the front and rear tires of the trailer.
2. Remove the lock pin (if equipped), then lift the lock handle and raise the latch.

Fifth Wheels and Trailer Couplings

3. Back up the vehicle until the drawbar eye is over the pintle hook.
4. Lower the trailer, until the drawbar eye rests on the pintle hook.
5. Push the latch closed, then insert the lock pin (if equipped).
6. Connect the trailer electrical and air lines.

NOTICE

Always make sure the connection hanger keeps the trailer air hoses and electrical cables positioned so that they do not rub on anything. Rubbing may wear through hoses or cables, resulting in air leaks, or exposed or broken wires, potentially affecting trailer brake or electrical systems.

Holland Coupling Trailer Release

WARNING

Do not use the trailer air supply for parking trailers not equipped with spring parking brakes. This applies the trailer service brakes only. As air bleeds from the trailer brake system, brake application is lost. This could allow the unattended vehicle to roll away, possibly resulting in serious personal injury or death.

1. Apply the tractor and trailer parking brakes.
2. Chock the front and rear tires of the trailer.
3. Disconnect the trailer air and electrical lines. Plug the air lines to keep them free of dirt.
4. Open the latch by removing the lock pin (if equipped), then lift up the lock and raise the latch.
5. Raise the mating drawbar above the pintle hook. See [Fig. 17.32, item 4](#).
6. Slowly drive the vehicle away from the trailer.

Premier Air Pintle Hitch Trailer Hookup

1. Chock the front and rear tires of the trailer.
2. Back up the vehicle until the drawbar eye is over the pintle hook.
3. Lower the trailer, until the drawbar eye rests on the pintle hook.

4. Connect the trailer electrical and air lines.

NOTICE

Always make sure the connection hanger keeps the trailer air hoses and electrical cables positioned so that they do not rub on anything. Rubbing may wear through hoses or cables, resulting in air leaks, or exposed or broken wires, potentially affecting trailer brake or electrical systems.

Premier Air Pintle Hitch Trailer Release

1. Apply the tractor and trailer parking brakes.

WARNING

Do not use the trailer air supply for parking trailers not equipped with spring parking brakes. This applies the trailer service brakes only. As air bleeds from the trailer brake system, brake application is lost. This could allow the unattended vehicle to roll away, possibly resulting in serious personal injury or death.

2. Chock the front and rear tires of the trailer.
3. Disconnect the trailer air and electrical lines. Plug the air lines to keep them free of dirt.
4. Raise the drawbar above the pintle hook.
5. Slowly drive the vehicle away from the trailer.

18

Headlight Aiming

Before Checking the Headlight Aim	18.1
Checking Headlight Aim	18.1
Adjusting Headlight Aim	18.1

Headlight Aiming

Before Checking the Headlight Aim

Before checking or adjusting the headlight aim, do the following:

- Check that the hood is closed and latched.
- Check the suspension for proper functioning of the leveling mechanism. On cabs with air suspensions, make sure that the height is properly adjusted.
- If necessary, remove any large amounts of mud or ice from the underside of the fenders.
- Check the springs for sagging or broken leaves.
- Check for damage to the hood and hinge assembly. Repair as necessary.
- With the vehicle unloaded, check that the tires are inflated to the recommended air pressure.
- Clean the headlight lenses. Use a soft cloth with mild, non-caustic soap or detergent, and water.

Checking Headlight Aim

1. Park the vehicle on a level surface, 25 ft (7.6 m) away from, and perpendicular to, a vertical screen or wall. Shut down the engine and set the parking brake. Chock the tires.
2. Each headlight has a height adjusting dot. See [Fig. 18.1](#). Measure the distance from the ground to the height adjusting dot on each headlight. Note those distances. See [Fig. 18.2](#), Ref. A.

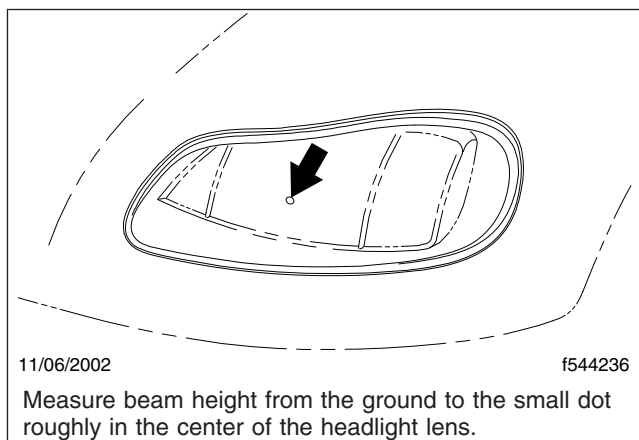

Fig. 18.1, Headlight Beam Height Adjusting Dot

3. Mark the vertical distances found in step 2 on the screen or wall, directly in front of the headlights. These marks represent the desired locations of each headlight bulb center in the following steps. See [Fig. 18.2](#), Items 2 and 3.
4. Turn on the low-beam headlights.
5. Identify the center of each beam projection by marking the area of brightest intensity on the wall. The area of brightest intensity should fall on or very near the marks made during step 3. See [Fig. 18.3](#).
6. Use [Table 18.1](#) to determine the maximum vertical distance allowable between the marks made in step 3 and the marks made in step 5. If the vertical distance between the marks made in steps 3 and 5 is greater than the maximum distance given in [Table 18.1](#), adjust the vertical positioning of that headlight.

Adjusting Headlight Aim

NOTICE

Do not use power tools to adjust headlight aim. Doing so will strip or break the adjusting screw.

1. Lift up the splash shield to expose the adjusting knob shown in [Fig. 18.4](#).
2. Turn the adjusting screw clockwise to raise the beam of the headlight or counterclockwise to lower it.
3. If necessary, adjust the other headlight.

Headlight Aiming

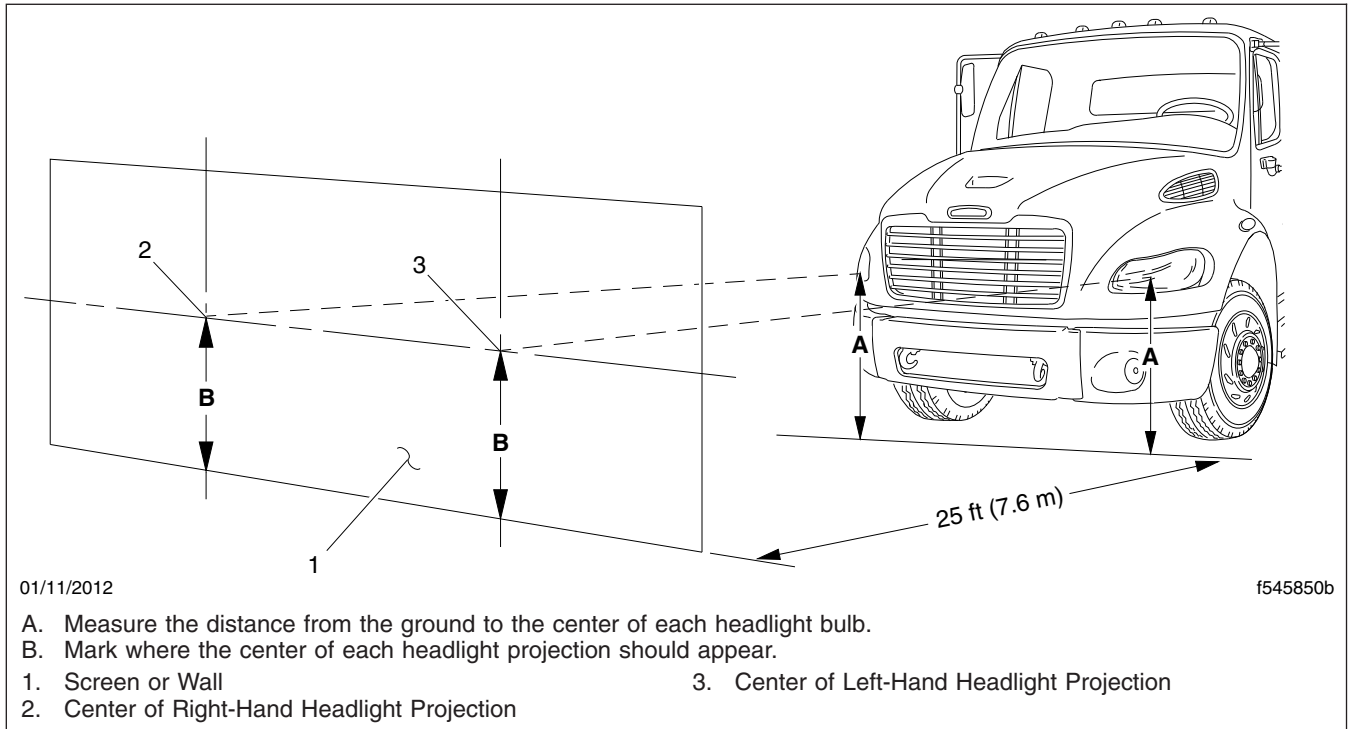

Fig. 18.2, Headlight Aiming Screen/Wall

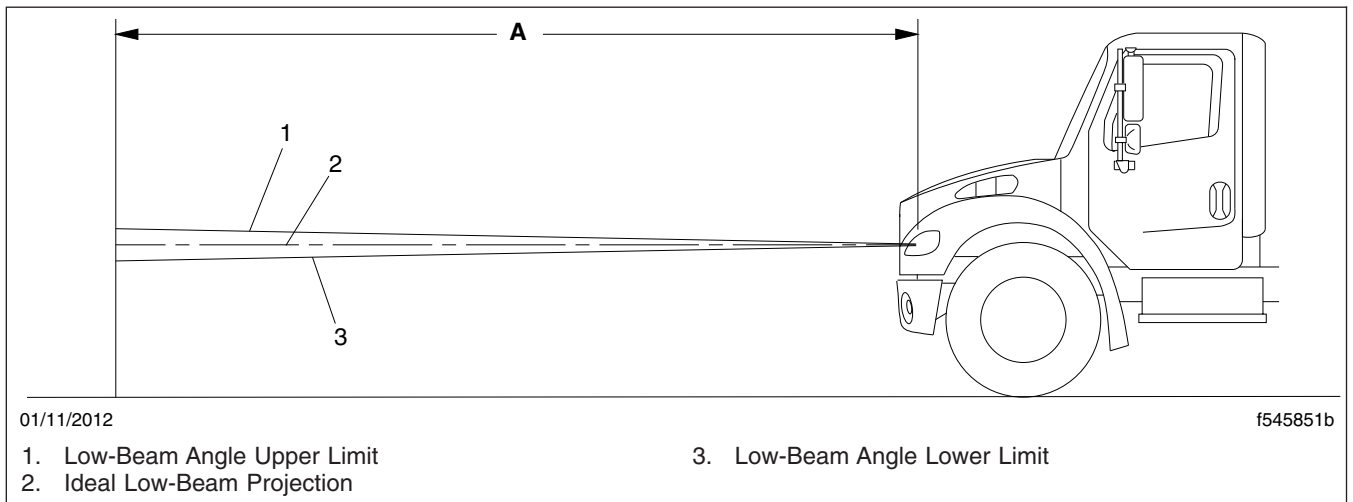

Fig. 18.3, Vertical Low-Beam Headlight Variation Limits

Headlight Aiming

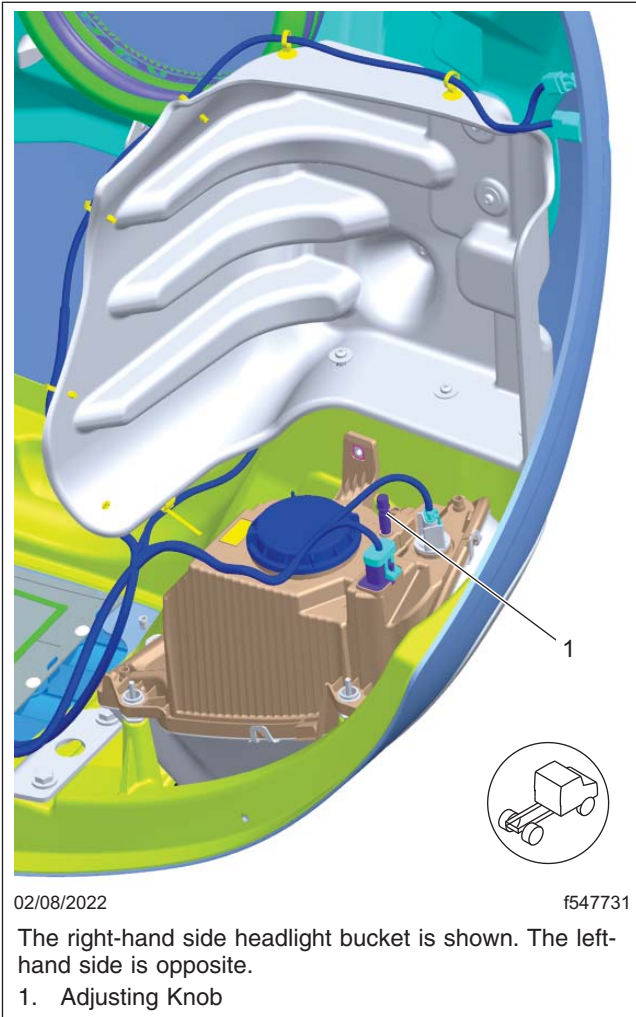

Fig. 18.4, Headlight Adjusting Knob

Vertical Low-Beam Headlight Variation Limits			
Distance Between Ground and Headlight: in (mm)	Desired Variation (Fig. 18.3, Item 2): in (mm)	Upper Limit (Fig. 18.3, Item 1): in (mm) up	Lower Limit (Fig. 18.3, Item 3): in (mm) down
22–36 (560–900)	0	3.9 (100)	3.9 (100)
36–48 (900–1200)	2 (50) down	2 (50)	6 (150)
48–54 (1200–1400)	4 (101.6) down	1.6 (40)	6.5 (165)

Table 18.1, Vertical Low-Beam Headlight Variation Limits

Natural Gas Vehicle Information

Natural Gas Vehicles, General Information	19.1
Natural Gas Vehicles, Safety Precautions	19.1
Natural Gas Engine Starting	19.2
Natural Gas Fuel Tank Filling Procedures	19.2
Natural Gas Detection System	19.5
Major Repair and Replacement of Natural Gas Components	19.9

Natural Gas Vehicle Information

Natural Gas Vehicles, General Information

The vehicle can be equipped with a compressed natural gas (CNG) fuel system, or a liquefied natural gas (LNG) fuel system.

CNG is made by compressing natural gas to less than 1% of its volume at standard atmospheric pressure. It often contains an odor-producing chemical.

LNG is created by condensing natural gas into a liquid by cooling it to approximately -259°F (-162°C). LNG does not have any odor.

For natural gas to burn, it must first vaporize, then mix with air in the proper proportions (flammable range is 5 to 15% by volume in air), and then be ignited.

A typical natural gas fuel system consists of:

- Fuel supply cylinders that store compressed gas at high pressure (CNG), or a tank that stores liquefied gas at an extremely low temperature (LNG).
- A vaporizer or heat exchanging device that changes LNG to gaseous form (LNG fuel systems only).
- Pressure relief and manual fuel shutoff valves.
- A filling connection with a check valve that prevents the gas from flowing back out of the fuel filling line.
- High-pressure and low-pressure fuel filters.
- A pressure control regulator that reduces the high fuel tank or cylinder pressure to the lower pressure needed for the engine.
- A fuel contents gauge that indicates the fuel supply in the tank or cylinders.

When vaporized at ambient temperatures, natural gas is less dense than air, and it rises and disperses. However, LNG is initially heavier than air due to its cryogenic temperature. When released in large amounts, it may drop or pool on the ground before its temperature rises enough to vaporize. Cold atmospheric conditions may prevent natural gas from dispersing quickly when released in large amounts.

Natural gas is nontoxic, but it can cause asphyxiation if present in very large concentrations.

Natural Gas Vehicles, Safety Precautions



Natural gas is highly flammable. Failure to observe the following safety precautions could lead to the ignition of the natural gas, which could cause serious bodily injury or death.

Follow these safety precautions when operating or repairing a natural gas vehicle.

- Do not start the engine if a natural gas leak is detected.
- Do not attempt to cut any fuel supply piping components.
- Avoid open flames or sparks near a natural gas vehicle.
- Cover eyes and exposed skin when working on a natural gas fuel system or fueling a natural gas vehicle.
- Always purge the fuel lines before performing maintenance or repairs on a natural gas fuel system. To purge the lines, close the manual fuel shutoff valve, and start the engine. Let the vehicle idle until the fuel lines are empty and the engine stops.
- Always use a natural gas detector to test the system for leaks, whether an odor is present or not. Routinely inspect the fuel filtering and regulating mechanisms, and the fuel lines. A bubble solution can be used to pinpoint the exact location of leaks.
- Always tighten fasteners and fuel connections to the required torque specification. Over-tightening or under-tightening could cause leaks.
- Close the fuel shutoff valve(s) before performing maintenance and repairs.
- Do not store a natural gas vehicle indoors for any extended period of time. Do not bring a natural gas vehicle indoors unless the workshop is equipped with a methane detection and ventilation system.
- Do not transfer CNG from one vehicle to another, as a buildup of static electricity could cause a spark and ignite the fuel.

- Do not permit smoking or other ignition sources within thirty feet of a natural gas vehicle.
- Have CO₂ fire extinguishers (ABC minimum) located in a highly visible and easily accessible location.
- Use Purple-K powder (PKP) or a similar dry powder to extinguish an LNG fire. Do not attempt use water around an LNG fire.

In Case of Emergency

If a vehicle has sustained damage or a leak has been discovered:

1. Turn the ignition switch off, set the parking brake, and disconnect the battery.
2. Remove all ignition sources from the area surrounding the vehicle.
3. If it is safe to do so, close all fuel shutoff valves.
4. Open the vehicle doors to introduce fresh air.
5. Use a natural gas detector to identify leaks in the fuel system.

Natural Gas Engine Starting

NOTE: Before starting the engine, read **Chapter 3** for detailed information on how to read the instruments and **Chapter 4** for detailed information on how to operate the controls. Read the operating instructions in the engine manufacturer's operation manual before starting the engine.

1. Before engine start-up, complete the engine pretrip and post-trip inspections and maintenance procedures in **Chapter 22**.
2. Ensure the fuel shutoff valve is open.
3. Set the parking brake.
4. Ensure that the transmission shift control is in Neutral (N), Park (P), or the Park Brake (PB) position.
5. Without starting the engine, turn the ignition switch to the ON position. See **Fig. 19.1**. The electronic gauges on the instrumentation control unit (ICU) will complete a full sweep of their dials, the warning and indicator lights will illuminate, and the buzzer will sound for three seconds.

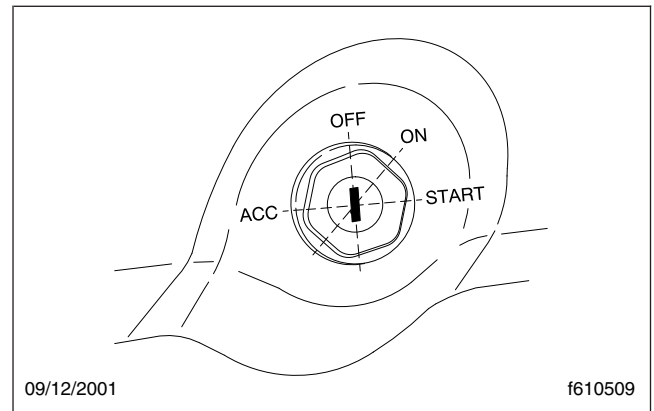

Fig. 19.1, Ignition Switch Positions

6. Turn the ignition switch to the START position. Press down on the clutch pedal, if equipped, but do not press down on the accelerator pedal. Release the key the moment the engine starts.
7. Bring the engine up to operating speed gradually as it warms up and develops stable oil pressure. If the vehicle has not been operated previously in a 24-hour period, allow the vehicle to idle for five minutes.

NOTICE

Do not rev the engine if the oil pressure gauge indicates no oil pressure. Shut down the engine within approximately ten seconds to avoid engine damage.

8. Check the oil pressure gauge for any drop in lubricating oil pressure or mechanical malfunction in the lubricating oil system.

Natural Gas Fuel Tank Filling Procedures

CNG Vehicle Fueling

CNG is moved from the fuel station storage tanks to the vehicle cylinders through a metered dispenser. During fueling, as pressure inside of the vehicle cylinders increases, so does the temperature. The dispenser shuts off when it determines the CNG cylinders are full.

CNG fuel cylinders cannot be filled to their full capacity of 3600 psi (24 800 kPa) in cooler weather. Since temperature change causes gas to expand and contract, less pressure in the cylinders on a cold

Natural Gas Vehicle Information

day is equal to the same amount of gas at a higher pressure on a warm day. The fuel station dispenser has a temperature-pressure compensating device, which accounts for ambient temperature during fueling. See [Table 19.1](#) for approximate full cylinder pressures at various temperatures.

CNG Temperature/Pressure Compensation Values		
Temperature: °F (°C)	Fill Station Pressure Set Point	
	3000 psi (20 684 kPa) Set Point	3600 psi (24 821 kPa) Set Point
100 (37.8)	3415 (23 546)	4086 (28 172)
90 (32.2)	3276 (22 587)	3909 (26 952)
80 (26.7)	3138 (21 636)	3754 (25 883)
70 (21.1)	3000 (20 684)	3600 (24 821)
60 (15.6)	2861 (19 726)	3445 (23 752)
50 (10)	2723 (18 774)	3288 (22 670)
40 (4.4)	2584 (17 816)	3131 (21 587)
30 (-1.1)	2446 (16 865)	2973 (20 498)
20 (-6.7)	2307 (15 906)	2814 (19 402)
10 (-12.2)	2169 (14 955)	2655 (18 306)
0 (-17.8)	2031 (14 003)	2495 (17 202)
-10 (-23.3)	1893 (13 052)	2336 (16 106)
-20 (-28.9)	1755 (12 100)	2180 (15 031)
-30 (34.4)	1616 (11 142)	2024 (13 955)
-40 (-40)	1477 (10 184)	1868 (12 879)

Table 19.1, CNG Temperature/Pressure Compensation Values

Use the following steps to fuel a CNG vehicle.

1. Shut down the engine and apply the parking brake.

IMPORTANT: Close all windows and doors during the fueling process. Keeping windows and doors closed allows for easier leak detection inside the cab after fueling.

WARNING

Natural gas fuel tanks, lines, and valves are always pressurized. Always observe safety precautions. Failure to do so could lead to loss of control over a filling hose or to ignition of the natural gas, which could cause serious bodily injury, death, or severe property damage.

2. Ensure all fuel cylinder shutoff valves are open. See [Fig. 19.2](#).
3. Ensure the vehicle fuel system main shutoff valve is open.

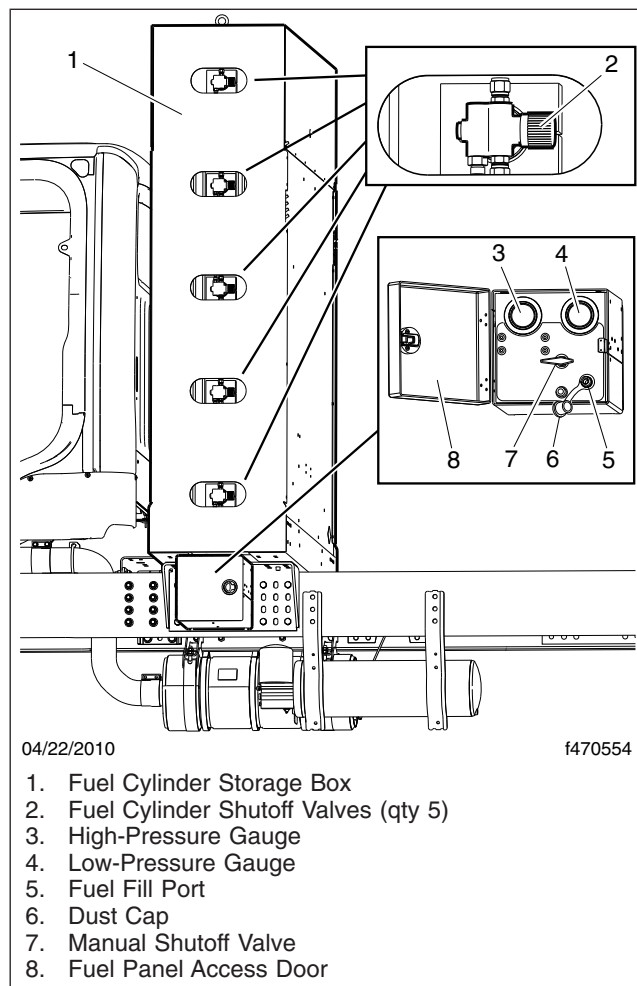

04/22/2010

f470554

1. Fuel Cylinder Storage Box
2. Fuel Cylinder Shutoff Valves (qty 5)
3. High-Pressure Gauge
4. Low-Pressure Gauge
5. Fuel Fill Port
6. Dust Cap
7. Manual Shutoff Valve
8. Fuel Panel Access Door

Fig. 19.2, CNG Fuel Cylinder Storage Box (5-cylinder system shown)

4. Open the CNG fuel panel access door and remove the dust cap from the vehicle fuel fill port.
5. Ensure the O-ring is present inside the fuel fill port. If the O-ring has been dislodged or is missing, the station dispensing nozzle will not connect securely to the fill port.
6. Turn the selector knob on the service pump to the VENT position, if equipped.
7. Connect the quick coupling on the dispensing nozzle securely to the vehicle fuel fill port.
8. Turn the selector knob on the service pump to the FILL position, if equipped.

IMPORTANT: If at any time the service pump or vehicle begins to vent CNG uncontrollably, notify

Natural Gas Vehicle Information

a station attendant or activate the service station emergency shut-off switch to cease the flow of CNG.

9. Switch on the service pump. A slight hissing noise may be heard as the fuel cylinders fill.
10. Watch the pressure gauge on the service pump. When the gauge reads approximately 3600 psi (24 800 kPa), or when the fill pressure stops climbing, the CNG cylinders are full. The service pump will shut itself down automatically. See [Table 19.1](#) for pressure compensation values based on ambient temperatures.
11. Move the selector knob on the service pump to the VENT position, if equipped. A short hiss will be heard as a small amount of natural gas is vented into the hose.

WARNING

Do not attempt to remove the fill station nozzle from the tank fill fitting until venting of pressure is noted. If no venting occurs, ask for assistance from the station attendant. Removing an unvented coupling could result in an uncontrolled hose, which could lead to property damage or personal injury.

12. Remove the station dispensing nozzle from the vehicle fill port.
13. Install the dust cap on the vehicle fuel fill port and close the fuel panel access door.

LNG Vehicle Fueling

The LNG fuel tank is designed to be filled from any LNG fuel source that has a 100 micron or finer fuel filter and a fuel delivery pressure between 120 and 225 psi (827 and 1551 kPa).

The LNG fuel tank is designed to be top-filled through a single hose with no vent return. As cold LNG is sprayed into the vapor space of the tank, the cold liquid condenses the vapor and creates space for itself inside the tank, eliminating any need to vent during the filling process.

The LNG tank is equipped with a small internal ullage tank for vapor space, which allows for fuel expansion and increases vehicle standby time. When an LNG tank is full, fuel can continue to flow into the ullage tank. However, if the ullage tank is completely filled during fueling, standby time will be reduced to zero and the primary relief valve will open almost immediately after fueling, allowing excess LNG vapor

to escape. If fueling is stopped when the ullage tank is empty (i.e., the fuel tank has sufficient vapor space to accommodate fuel expansion due to temperature increase), the vehicle will have approximately one week of standby time before venting will occur.

Use the following steps to fuel an LNG vehicle.

1. Shut down the engine and apply the parking brake.

IMPORTANT: Close all windows and doors during the fueling process. Keeping windows and doors closed allows for easier leak detection inside the cab after fueling.

WARNING

Liquefied natural gas is a cryogenic liquid stored at approximately -259°F (-162°C). Cryogenic burns can be caused by coming into contact with the pressurized liquid stream, or by coming into contact with fuel system components that have been cooled to cryogenic temperatures. Always wear gloves and a face shield, and cover exposed skin when fueling.

2. Remove the fuel fill fitting dust cap. See [Fig. 19.3](#).

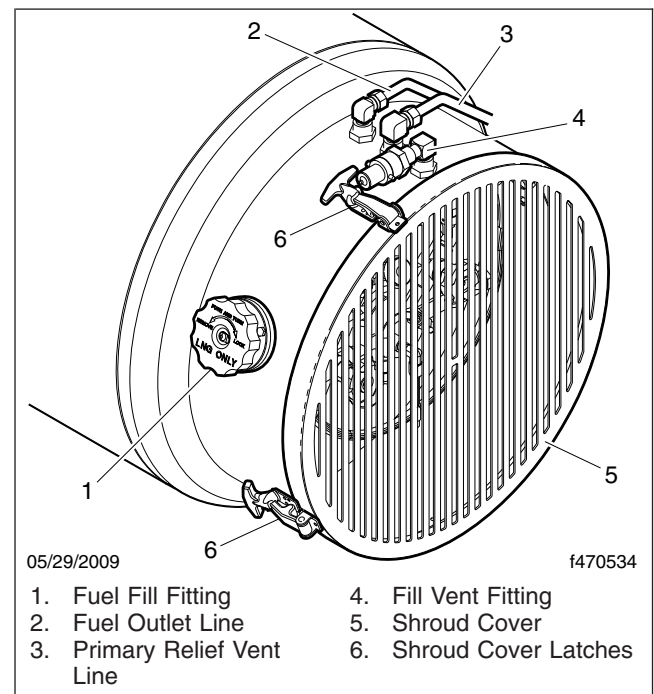

Fig. 19.3, LNG Fuel Tank

Natural Gas Vehicle Information

- Using compressed air, remove any dirt, debris, or water that may have collected in the fuel fill fitting and the station dispensing nozzle. Contaminants in the fuel system can cause drivability problems.

WARNING

Natural gas fuel tanks, lines, and valves are always pressurized. Always observe safety precautions. Failure to do so could lead to loss of control over a filling hose or to ignition of the natural gas, which could cause serious bodily injury, death, or severe property damage.

- Connect the station fueling nozzle to the tank fuel fill fitting.
- Connect an electrical ground clamp and cable to the fuel tank.

IMPORTANT: An LNG tank which is first installed, or is on a vehicle that has not been operated in approximately ten days, is considered to be a hot tank. When fueling a hot tank, LNG entering the tank will immediately vaporize, causing tank pressure to spike above 250 psi (1724 kPa) and automatically shutting down the station fuel pump. To prevent the pump from shutting down, connect a vent line to the fill vent fitting on the LNG tank to capture escaping vapor, then open the shroud cover and open the vapor shutoff valve. See [Fig. 19.4](#), item 2.

- Open the station's fill valve, if equipped, and start fueling. Monitor the flow or line pressure as filling progresses. When filling begins, line pressure will spike quickly until the vehicle tank cools down. The flow and pressure will then remain stable during the remainder of the filling procedure.

IMPORTANT: When fueling a hot tank, initially put 5 to 10 gallons (19 to 37 liters) of LNG in the tank and manually stop the fueling process. Drive the vehicle for 15 to 20 minutes to cool the tank and reduce tank pressure, then continue fueling the tank to full.

- When the tank is full, the line pressure will rapidly spike and the flow rate will fall. When a pressure rise or flow rate drop is observed, close the station's fill valve, if equipped.

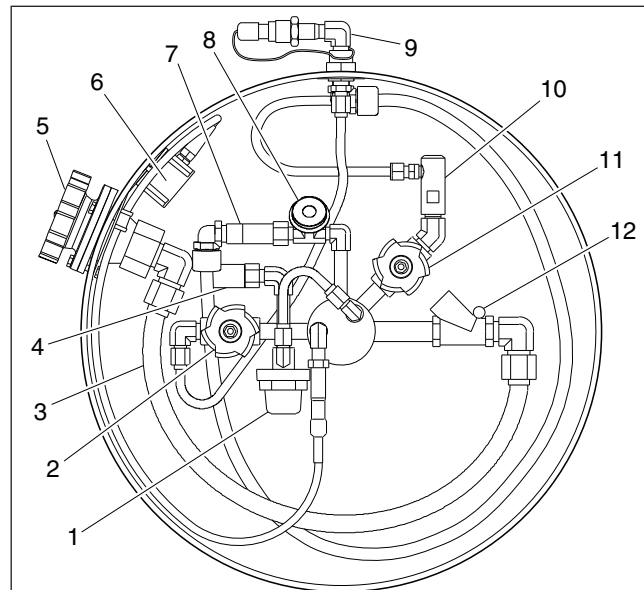

05/05/2010

f470533

- Pressure Control Regulator
- Vapor Shutoff Valve
- Fuel Fill Hose
- Secondary Relief Valve (red cap)
- Fuel Fill Fitting
- Fuel Level Sender Box
- Primary Relief Valve
- Tank Pressure Gauge
- Fill Vent Fitting
- Excess Flow Valve
- Fuel Shutoff Valve (liquid)
- Fill Check Valve

Fig. 19.4, LNG Fuel Tank Plumbing Components

NOTE: Do not over-fill an LNG tank. If the ullage tank is completely filled during fueling, tank standby time will be reduced to zero and the primary relief valve will open almost immediately after fueling.

- Disconnect the station hose from the tank fuel fill fitting.
- Disconnect the electrical ground clamp and cable from the fuel tank.
- Install the dust cap on the tank fuel fill fitting.

Natural Gas Detection System

A gas detection system is standard equipment in all Daimler Truck natural-gas-fueled vehicles. This system has a sensor in the engine compartment and one in the cab, both situated in high areas to detect natural gas buildup as a result of leaks. This device

is meant to serve as a supplemental warning only. It is not intended to replace standard safety practices that should be conducted around flammable gases.

IMPORTANT: To function properly, the gas detection system must be powered at all times. The gas detection system is directly powered by the batteries, and can only be powered off by disconnecting the batteries. When servicing a natural-gas-fueled vehicle, disconnect the batteries only when necessary, and do not leave the batteries disconnected for extended periods of time.

The lower flammability limit (LFL) is the smallest amount of the gas that supports a flame when mixed with oxygen and ignited. Zero percent (0%) LFL indicates a gas-free atmosphere. One hundred percent (100%) LFL indicates that gas concentration has reached its lower flammability limit (5% gas in air by volume). The red warning light and audible alarm located in the overhead console activate when a sensor detects gas fumes in concentrations above 50% LFL, and should allow ample time to utilize safety procedures. However, individuals with special needs should review the system with a professional safety engineer.

Alarm Procedure

Before operating the vehicle, the driver must be familiar with the procedures as shown on the interior sticker on the overhead panel, shown in [Fig. 19.5](#) and the exterior sticker on the door shown in [Fig. 19.6](#).

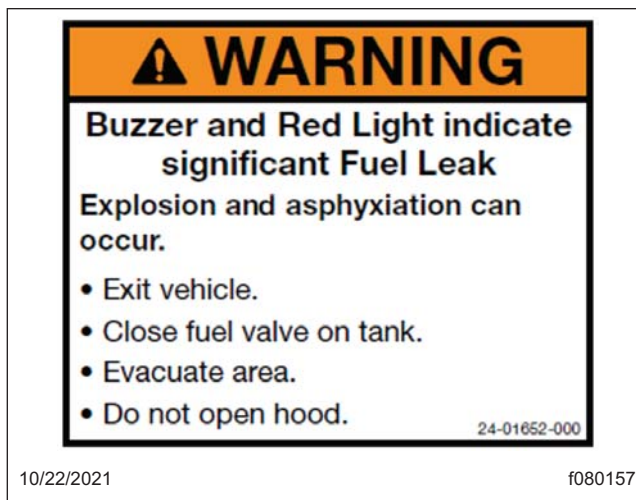

Fig. 19.5, Interior Warning Sticker

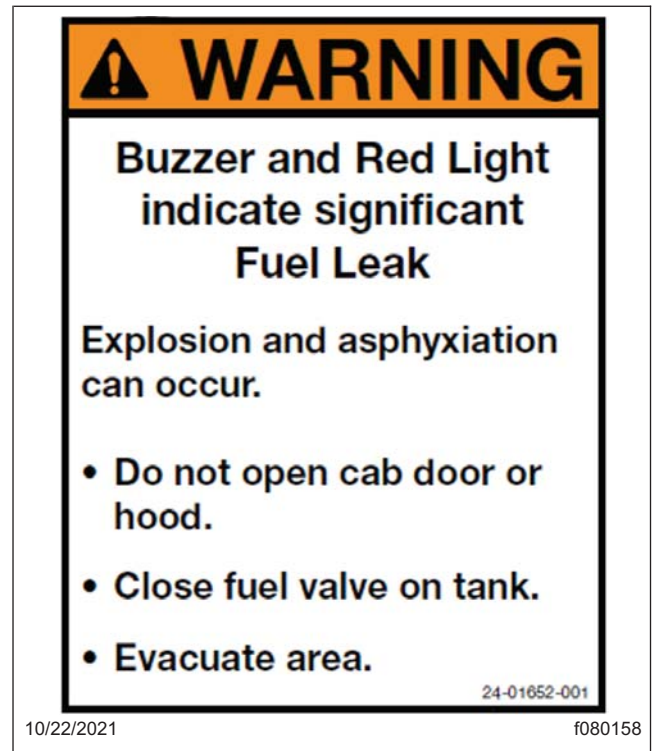

Fig. 19.6, Exterior Warning Sticker

IMPORTANT: If an audible alarm activates, do not operate any electrical switch, including lights. Avoid causing sparks and stay away from arcing switches and equipment. Do not use a phone or any electronic device that have a battery.

If the vehicle is in motion when the audible alarm activates, bring it to a safe stop, shut down the engine, and exit the vehicle. *Do not open the hood.*

If outside the vehicle when the audible alarm activates, *do not open the cab door or hood.*

In the event of an audible alarm, immediately follow these procedures, as allowed by conditions:

1. Immediately shut off all engines. Extinguish any cigarettes, pilot lights, flames, or other sources of ignition in the area and adjacent areas.
2. Manually close all fuel shutoff valves, including those on the LNG tank or CNG cylinders.
3. If the vehicle is indoors (as in a service shop), immediately open windows and doors to provide extra ventilation to the area. Do not start the engine or any other type of equipment until the

Natural Gas Vehicle Information

gas leak is corrected and the area cleared of natural gas.

4. Evacuate the area.
5. Check the fuel lines, LNG tank/CNG cylinders, and fittings to locate the leak. After the area is cleared of natural gas and the alarm is no longer active, have the vehicle inspected by a qualified technician.

IMPORTANT: Do not consider the area clear until all alarm indicators are off, and the alarm panel light returns to green.

Sensors

Gas detection sensors are located in the cab and in the engine compartment on the front wall. The sensors are located in high areas, where rising gas vapors will pass by or accumulate.

If the system detects that one of the sensors has been disconnected or has malfunctioned, the sensor fault light for that zone will illuminate. A failed sensor may trigger and lock on an alarm. If a fault condition or locked alarm is triggered, have the vehicle serviced before operating.

The sensors are sensitive to all hydrocarbon vapors. An alarm may be triggered by the use of chemicals such as cleaners, paint, polish, lacquer, gasoline, silicone, silicone spray, or other harsh chemicals. The sensors will also detect hydrogen fumes from an overcharged battery. If a sensor sends an alarm, but no gas fumes are present, check for recent use of chemicals or a battery charger.

NOTICE

Silicone-based chemicals and cleaners will permanently disable the sensors. When cleaning the vehicle, cover the sensors with a plastic covering. Keep the sensors covered until the area has been cleared of any cleaning fumes.

Harsh chemicals and extremely high temperatures may damage the sensor.

Puncture of or damage to the seal located inside the sensor housing will significantly shorten the sensor life.

Frequent exposure to high concentrations of gas will accelerate sensor deterioration.

Control Module and Alarm Panel

The gas detection system control module is located on the center dash panel. See **Fig. 19.7**. The alarm panel is located on the overhead consol. It has a green light, a red light, a buzzer, and a sensor. See **Fig. 19.8**. It is located within view from outside of the vehicle. The large green light is continuously illuminated during normal operating conditions. There is also a forward-facing alarm panel located at the top center of the windshield for easy viewing from the front of the vehicle. This panel only has the green and red lights. See **Fig. 19.9**.

Before entering the vehicle, always verify that the green light is illuminated. If the green light is not illuminated, do not enter the vehicle. Complete the alarm procedure previously outlined.

The control module and the alarm panels meet the California Highway Patrol Title 13-2008 and NFPA 52 2010 requirements. All drivers and technicians using it should be trained regarding the red and green lights, and the audible warning.

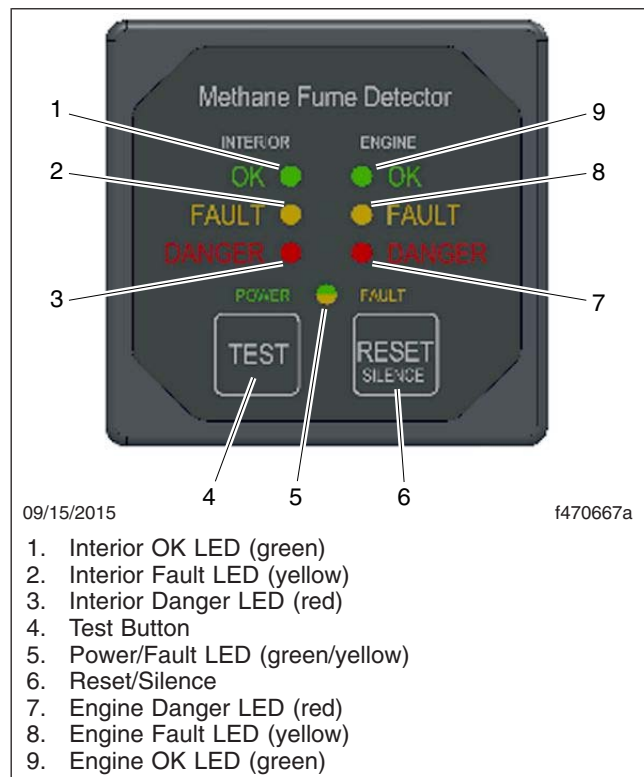

Fig. 19.7, Control Module

The control module, located on the center dash panel, contains the status lights and control buttons

Natural Gas Vehicle Information

Fireboy Control Module Functions			
Item	Display	Function	Action Required
Engine OK LED (green)	Illuminated	Engine sensor is detected, signal is OK, and system power is on.	None required.
Engine Fault LED (yellow)	Illuminated	Engine sensor is not detected, or there is a signal malfunction.	Have the system checked immediately.
Engine Danger LED (red)	Illuminated	The engine sensor is reading an amount of gas greater than 20% LFL.	Suspend vehicle operation immediately and follow alarm procedures.
Reset/Silence	—	Turns the relay off when in alarm mode.	Press the button.
Power/Fault LED (green/yellow)	Illuminated (green)	System is on.	None required.
	Illuminated (yellow)	Not used.	Not used.
Buzzer	Sounding	Gas is detected at a level above 50% LFL in the specified zone.	Suspend vehicle operation immediately and follow alarm procedures.

Table 19.2, Control Module Functions

Testing

Daimler Truck North America strongly recommends that all operators follow California Code of Regulations (CCR) inspection requirements, regardless of where the vehicle is operated. Per Title 13 CCR § 935 (2), gas detection systems should be tested three times per calendar year at equal intervals. The testing procedure should simulate the same operating environment in which the vehicle is used, with the same gaseous fuel.

Test results validating the performance of the gas detection system within the parameters established by the component manufacturer and NFPA 52 2010 should be maintained as a permanent part of the vehicle service records. Use of alcohol, propane, and other harsh liquids or gases are not acceptable methods for testing.

Always test the system and sensors after any component has been replaced, or if the vehicle has been involved in an accident or fire. Ensure that the gas detection system is wired directly to the battery.

It is recommended that the highest level of safety validation be utilized if there are multiple validation requirements in the state or locality where the vehicle is operated or domiciled.

Control Module Console Test

Press and hold the *Push To Test* button for one minute. The system will proceed with a self-diagnostic test that will include illumination of the *Trace* and *SIGNIFICANT* gas concentration lights, and the sensor fault lights. Verify the large red light

and buzzer activate, and that all lights illuminate or flash to ensure that all bulbs are operational.

Sensor Test

The gas detection system sensors must be tested regularly by a trained technician, using certified test equipment that satisfies CCR § 935 (2) or NFPA 52 regulations.

Major Repair and Replacement of Natural Gas Components

If a natural-gas-fueled vehicle is involved in an accident, remove the fuel tank or cylinders from service and have them inspected by a qualified technician. Replace any leaking or damaged fuel tanks/cylinders and fuel lines; repair or replace leaking or damaged fittings. Install parts and components in accordance with the manufacturer's instructions.

20

Vehicle Appearance and Care

Cleaning and Disinfecting Cab Surfaces	20.1
Cleaning the Upholstery	20.2
Washing and Polishing the Cab	20.4
Care of Exterior Lights	20.4
Caring for External Chrome Components	20.4
Care of Fiberglass Parts	20.5

Vehicle Appearance and Care

Cleaning and Disinfecting Cab Surfaces

Safety

The following guidelines are for cleaning and disinfecting commonly touched surfaces on the inside and outside of a vehicle.

For best results, follow cleaning and disinfecting procedures fully and consistently. Ensure there is adequate ventilation when using chemicals.

- Doors and windows should remain open when cleaning inside the vehicle.
- When cleaning and disinfecting, individuals should wear disposable gloves compatible with the products being used as well as any other personal protective equipment (PPE) required according to the product manufacturer's instructions and the safety data sheet (SDS).
- Gloves and any other disposable PPE used for cleaning and disinfecting the vehicle should be removed and disposed of after use.
- Wash hands with soap and water for at least 20 seconds immediately after removal of gloves and PPE, or use an alcohol-based hand sanitizer with at least 60 percent alcohol.

Cleaning and Disinfecting High-Touch Surfaces

NOTE: Depending on how a vehicle is used, it may be helpful to create an inclusive checklist of high-touch surfaces to regularly clean.

To clean surfaces, soak a microfiber cloth with a detergent/water solution, wring the cloth out, and wipe down high-touch areas. Allow the detergent water/solution to sit on the surface for 20-30 seconds before using a fresh microfiber cloth slightly dampened with water to remove it.

After this soap and water wash, Freightliner recommends the use of either a dilutable or ready to use quaternary ammonium based disinfectant on vehicle interior and exterior surfaces.

IMPORTANT: Follow the manufacturer's instructions for using a disinfectant as these vary by product.

NOTICE

Any disinfectant dispensed by a pressurized aerosol container is not recommended. The direct spray of liquids onto the vehicle's interior panels, electronic components, or permeable materials is not recommended.

Using an aerosol disinfecting spray may cause damage to parts of the vehicle.

Examples of either a dilutable or ready to use quaternary ammonium based disinfectant include:

- Lysol® Deodorizing Disinfectant Cleaner
- Fantastik® Disinfectant Multi-Purpose Cleaner
- Hillyard Vindicator®+ Disinfectant

All exterior high-touch surfaces should be cleaned with soap and water before applying disinfectant.

Exterior high-touch surfaces include, but are not limited to, the following:

- grab handles
- door handles
- hood latches and handles
- trailer glad hands

Freightliner recommends applying the disinfectant solution to a microfiber cloth until it is damp but not dripping and then wiping down high-touch areas. Take care to fully wet surfaces with the disinfectant, and ensure that it remains wet for the period of time stipulated by the disinfectant manufacturer to effectively disinfect the surface. Afterwards, if necessary, wipe off excess disinfecting solution with a new clean cloth.

If an interior high-touch surface is visibly dirty, clean it before applying disinfectant; if it appears clean, wipe down the area with disinfectant.

Interior high-touch surfaces include, but are not limited to, the following:

- grab handles
- seats
- arm rests
- steering wheel
- switch pods
- shift knob
- door handles

- seat belt buckles
- light and air controls
- doors and windows

Dashboard and Touch Screen Care

NOTICE

When cleaning the dashboard do not use Armor-All Protectant®, STP Son-of-a-Gun®, window cleaner, or other equivalent treatments. These cleaners contain vinyl plasticizers which can cause stress crazing and cracking in the interior plastic panels. This type of damage is not covered by vehicle warranty.

Wipe down fragile components carefully to avoid damaging the vehicle.

Do not directly spray the screen or any other device in the vehicle. Do not use soap and water on a touch screen. Excess water or disinfectant will damage electrical components.

If the vehicle contains a touch screen, follow the manufacturer's instructions for cleaning and disinfecting it. If manufacturer guidance is unavailable, spray a lint-free cloth with a mix of at least 70 percent isopropyl alcohol and distilled water and gently wipe down the screen and then dry it with a clean cloth.

Cleaning and Disinfecting Chemicals to Avoid

Unless specifically specified, Freightliner vehicles should **not** be cleaned or disinfected with products that contain the following chemicals:

- hydrogen peroxide
- sodium chlorite
- sodium hypochlorite (chlorine bleach)
- glycol acid
- octanoic acid
- hypochlorous acid
- silicone

Cleaning the Upholstery

NOTE: Using diluted laundry detergent to clean cloth seats may create excess suds.

To prevent soiling, frequent vacuuming or light brushing to remove dust and dirt is recommended. In most cases, quickly wiping down a seat with a damp cloth will remove dirt, spills, and pet hair.

To preserve the upholstery and prevent damage, review the following sections for recommended cleaning procedures.

Cleaning Cloth Seats

Vacuuming cloth seats regularly and quickly wiping down the seats with a damp cloth to remove dirt, debris, spills, and pet hair should keep the seats looking new.

For resistant or greasy stains, spray a small amount of upholstery cleaner on the stain, work it in with a small scrub brush, and let it sit for fifteen minutes prior to wiping it up. For larger areas, start at the top of the stained area so any dirty solution drips down. Follow any product label directions about diluting the cleaner prior to use.

If seats are deeply soiled, clean in multiple rounds or, if possible, remove the seat covers and wash them in a washing machine.

CODURA® cloth seats: If needed, apply a mild liquid soap to a damp cloth and rub the stained area. Follow this with wiping down the area with a clean water dampened cloth. Allow seats to dry before using them. Spray-on upholstery cleaners can also be used and then vacuumed off.

Durawear™ cloth seats: Durawear fabric is coated with PVC on the backside, making the seats waterproof. Start cleaning with a water dampened cloth. If needed, use upholstery cleaner or, if the seat covers are removable, wash them in washing machine. Do not dry Durawear seat covers in a dryer. Allow seat covers to air dry before using.

If needed, Durawear seats can be disinfected by wiping them down with solution consisting of 10 percent bleach and 90 percent water.

Fabriform® seats: Fabriform is a tri-laminate of film, foam, and fabric with superior wear resistance. To clean dirt, stains, and spills, wipe with a damp cloth. If needed, scrub with a soft scrub brush with mild soap or use an upholstery cleaner. Fabriform seats can be hosed off, if necessary.

Faux Leather Cleaning

In general, faux leather seats can be wiped clean with a rag and warm water.

Vehicle Appearance and Care

Water-soluble spills and stains can be removed with mild soap and water. Gently wipe the stain with a soapy cloth or sponge. After cleaning the stain or spill, remove any remaining soap solution by wiping the area with a cloth and clean water. As a final step, dry the surface with a soft lint-free cloth or towel.

Non-water soluble stains caused by oils, such as lotions and foods, can be cleaned with 50 percent solution of isopropyl alcohol and water. Rinse the cleaned area with water after applying the alcohol solution. Dry with a clean, lint-free cloth.

Faux leathers can be disinfected by wiping them down with solution consisting of 10 percent bleach and 90 percent water. After disinfecting, wipe down with a clean damp cloth and then dry with a clean dry cloth.

Avoid cleaners containing abrasives, as these can damage the product's coating.

Vinyl Upholstery Cleaning

Harsh cleaning agents can cause permanent damage to vinyl upholstery. Waxing or refinishing improves soil resistance for all vinyls.

Ordinary Dirt

Wash the upholstery with warm water and mild soap, such as saddle or oil soap. Apply soapy water to a large area and let it soak for a few minutes, then rub briskly with a cloth to remove the dirt. This can be repeated several times, as necessary.

If dirt is deeply imbedded, use a soft bristle brush after applying the soap.

If dirt is extremely difficult to remove, wall-washing preparations normally found around the home can be used.

Powdered cleaners, such as those used for sinks and tiles, are abrasive and must be used with caution as they can scratch the vinyl or give it a permanent dull appearance.

Chewing Gum

Harden the gum with an ice cube wrapped in a plastic bag, then scrape it off with a dull knife. Any remaining traces of gum can be removed with an all-purpose light oil (peanut butter will also work) and wiped off.

Tars, Asphalts, and Creosote

Each of these items stains vinyl after prolonged contact. They should be wiped off immediately and the area carefully cleaned, using a cloth dampened with naphtha.

Paint, Shoe Heel Marks

Paint should be removed immediately. Do not use paint remover or liquid-type brush cleaner on vinyl. An unprinted cloth, dampened with naphtha or turpentine may be used. Use care to prevent contact with parts of the upholstery that are not vinyl.

Sulfide Stains

Sulfide compounds, such as those found in eggs and some canned goods, can stain after prolonged contact with vinyl. These stains can be removed by placing a clean, unprinted piece of cloth over the spotted area and pouring a liberal amount of 6 percent hydrogen peroxide onto the cloth. Allow the saturated cloth to remain on the spot for 30 to 60 minutes. For stubborn spots, allow the hydrogen-peroxide saturated cloth to remain on the area overnight. Use caution to prevent the solution from seeping into the seams, or it will weaken the cotton thread.

Nail Polish and Nail Polish Remover

Prolonged contact with these substances causes permanent damage to vinyl. Careful blotting immediately after contact minimizes damage. Do not spread the liquid during removal.

Shoe Polish

Most shoe polishes contain dyes which penetrate vinyl and stain it permanently. Shoe polish should be wiped off as quickly as possible using naphtha or lighter fluid. If staining occurs, try the procedure used for sulfide stains.

Ball Point Ink

Ball point ink can sometimes be removed if rubbed immediately with a damp cloth, using water or rubbing alcohol. If this does not work, try the procedure used for sulfide stains.

Miscellaneous

If stains do not respond to any of the treatments described above, it is sometimes helpful to expose the vinyl to direct sunlight for up to 30 hours.

Mustard, ball point ink, certain shoe polishes, and dyes often bleach out in direct sunlight, leaving the vinyl undamaged.

Washing and Polishing the Cab

NOTICE

When pressure washing the vehicle or leaving the hood open when parked outdoors and subject to rain, cover the air cleaner inlet with a plastic bag to prevent water from entering the air intake system and possibly damaging the engine.

IMPORTANT: Carefully read all instructions before using or applying any cleaner or product on the vehicle or components. Failure to follow manufacturers' recommendations can result in damage to the finish.

Protecting Your Vehicle's Finish

To protect the finish of your new vehicle, follow these guidelines carefully:

- During the first 30 days, rinse your vehicle frequently with water. If the vehicle is dirty, use a mild liquid soap. Do not use detergent.
- During the first 30 days, do not use anything abrasive on your vehicle. Brushes, chemicals, and cleaners may scratch the finish.
- During the first 120 days, do not wax your vehicle.

Keeping Your Vehicle Looking New

To extend the life of your vehicle's finish, follow these guidelines:

- Avoid washing your vehicle in the hot sun.
- Always use water. After the cab is completely washed, dry it with a towel or chamois.
- Do not dust painted surfaces with a dry cloth, as this will scratch the paint.
- Do not remove ice or snow from a painted surface with a scraper of any sort.
- To prevent damage to the finish, wax it regularly. If the finish has become dull, before waxing, remove oxidized paint using a cleaner specifically designed for this purpose. Remove

all road tar and tree sap before waxing. Freightliner recommends that a quality brand of cleaner or cleaner-polish and polishing wax be used.

- Do not let diesel fuel or antifreeze stand on a painted surface. If either should occur, rinse the surface off with water.
- To prevent rust, have any nicks or other damage on the finish touched up as soon as possible.
- Park your vehicle in a sheltered area whenever possible.

Protecting Vehicle Labeling

A majority of the labels applied to cab are required for reasons of safety or identification. To prevent delamination and deterioration of labels and stickers, follow these guidelines carefully:

- Do not pressure wash the label or sticker or surfaces near it.
- Do not use strong alkaline soaps on or near the label or sticker.

Care of Exterior Lights

NOTICE

Do not use a power buffer, paper towels, chemical solvents, or abrasive cleaners on the headlight lens, all of which can remove the UV coating from the surface, and result in yellowing of the lens.

Clean the headlight lenses by hand only, using a flannel cloth with mild, non-caustic soap or detergent, and water.

Caring for External Chrome Components

NOTE: Chrome components are optional on the M2 Plus.

To prevent rust, keep chrome parts clean and protected at all times. This is especially important during winter driving and in coastal areas where there is exposure to salt air.

When cleaning chrome parts, use clean water and a soft cloth or sponge. A mild detergent may also be used.

Vehicle Appearance and Care

Sponge gently, then rinse. If necessary, use a non-abrasive chrome cleaner to remove stubborn rust or other material. Do not use steel wool.

To help protect the chrome after cleaning, apply a coat of polishing wax to the surface. Never use wax on parts that are exposed to high heat, such as exhaust pipes.

Care of Fiberglass Parts

NOTE: The standard M2 Plus hood is fiberglass.

Wash fiberglass components with a mild detergent, such as dishwashing liquid. Avoid strong alkaline cleansers and bleach. Apply a wax specifically designed for fiberglass.

21

Pre- and Post-Trip Checklists

Periodic Inspections and Maintenance, General Information	21.1
Checklists	21.1
Fluids Added	21.2

Pre- and Post-Trip Checklists

Periodic Inspections and Maintenance, General Information

It is the driver's responsibility to perform an inspection, and ensure the complete road-worthiness of a vehicle, before placing it into service.

Commercial vehicles may be subject to inspection by authorized inspectors, and an unsafe vehicle can be taken "out of service" until the driver or owner repairs it.

Use the following checklists to ensure that vehicle components are in good working condition before each trip. Careful inspections eliminate stops later to fix overlooked or forgotten items.

The checklists in this chapter can be copied and kept as a record that the procedures have been completed. For details on how to inspect each item on the checklists, see the corresponding procedure (step number) in [Chapter 22](#).

Checklists

NOTE: Checklists in this chapter correspond with the procedures and steps in [Chapter 22](#), *Pre- and Post-Trip Inspections and Maintenance*. Your vehicle may not be equipped with all components listed below.

Daily Pretrip Inspection Checklists

See the following tables for a list of procedures that should be performed daily, before the first trip. Place a check mark in the complete (**Comp.**) column to indicate a procedure has been performed.

Inspector	Date

Suspension and Slack Adjusters		Comp.
1	Suspension components	
2	Slack adjusters	

Wheels and Tires		Comp.
1	Wheel covers	
2	Tire condition	
3	Tire inflation	
4	Rims and wheel components	
5	Wheel bearing oil seals and lubrication levels	
6	Mud Flaps	

Saddle Tank Areas		Comp.
1	Drain air reservoirs (without automatic drain valves)	
2	Fuel tank(s) secure	
3	Frame rails and crossmembers	
4	Visible exhaust components	

Engine Compartment		Comp.
1	Leakage under engine	
2	Air intake system	
3	Engine oil level	
4	Power steering reservoir level	
5	Engine coolant level	
6	Visible engine wiring	
7	Frame rails	

Cab		Comp.
1	Reset dash-mounted air intake restriction indicator (if equipped)	
2	Air pressure warning systems	
3	Air governor cut-in and cut-out pressures	
4	Air pressure build-up time	
5	Air system leakage	
6	Air pressure reserve	
7	Mirrors, windows, windshield	
8	Horn, windshield wipers, windshield washers	
9	Heater and defroster	
10	Interior lights	
11	Exterior lights	
12	Seat belts and tether belts	
13	Fuel level	
14	Mirror adjustment	
15	Service brakes	
16	Backup alarm	

Weekly Post-trip Inspection Checklist

See the following table for procedures that should be performed weekly, post-trip. Place a check mark in the complete (**Comp.**) column to indicate a procedure has been performed.

Inspector	Date

Engine Compartment		Comp.
1	Windshield washer reservoir level	
2	Air intake restriction indicator	
3	Water evacuation components	
4	Automatic transmission fluid level	
5	Water in fuel/water separator	

Pre- and Post-Trip Checklists

Engine Compartment		Comp.
6	Steering components	
7	Serpentine drive belts	

Fluids Added During Inspection	
Fluid	Amount Added
Hydraulic Clutch Fluid (DOT 4 brake fluid)	

Monthly Post-trip Inspection Checklists

See the following tables for procedures that should be performed monthly, post-trip. Place a check mark in the complete (**Comp.**) column to indicate a procedure has been performed.

Inspector	Date

Brake Components		Comp.
1	Brake system components	
2	Brake chambers	
3	Air brake lines	
4	Flex air hoses	
5	Brake linings and brake drums	
6	Brake lining thickness	

Saddle Tank Areas		Comp.
1	Drain air reservoirs (with automatic drain valves)	
2	Batteries (location may vary)	
3	Aerodynamic components	

Engine Compartment		Comp.
1	Hood and bumper	
2	Hydraulic clutch reservoir	
3	Radiator and heater hoses	
4	Steering wheel play	

Fluids Added

Use the following table to note any fluids that were added during the inspection and maintenance procedures.

Fluids Added During Inspection	
Fluid	Amount Added
Wheel Bearing Lubricant	
Engine Oil	
Power Steering Fluid	
Engine Coolant	
Windshield Washer Fluid	
Automatic Transmission Fluid	

Pre- and Post-Trip Inspections and Maintenance

Safety Precautions	22.1
Daily Pretrip Inspections and Maintenance	22.1
Weekly Post-Trip Inspections and Maintenance	22.9
Monthly Post-Trip Inspections and Maintenance	22.11

Pre- and Post-Trip Inspections and Maintenance

Safety Precautions



When working on the vehicle, shut down the engine, set the parking brake, and chock the tires. Before working under the vehicle, always place jack stands under the frame rails to ensure the vehicle can not drop. Failure to follow these steps could result in serious personal injury or death.

Daily Pretrip Inspections and Maintenance

Complete the following inspection and maintenance procedures to ensure that vehicle components are in good working condition before each trip. A driver who is familiar with the vehicle and drives it regularly can perform the daily inspections, then add the weekly and monthly post-trip inspections as scheduled.

If the driver does not operate the vehicle on a consistent basis, all daily, weekly, and monthly inspection and maintenance procedures should be performed before the trip.

IMPORTANT: The pre- and post-trip checklists, inspections, and maintenance procedures detailed in this chapter are **not all-inclusive**. Refer to other component and body manufacturers' instructions for specific inspection and maintenance instructions, as well as local, state, and federal guidelines.

NOTE: If any system or component does not pass this inspection, it must be corrected before operating the vehicle. Whenever equipment requires adjustment, replacement, and/or repair, see the *M2 Plus Workshop Manual* for procedures and specifications.

Suspension and Slack Adjuster Inspection

Walk around the vehicle and visually inspect suspension and slack adjuster components.

1. Inspect the following suspension components for signs of structural damage, cracks, or wear.
 - springs
 - spring hangers

- shocks
- suspension arms
- suspension brackets
- axle seats
- bushings

2. Inspect slack adjusters for signs of damage. See [Fig. 22.1](#), [Fig. 22.2](#), or [Fig. 22.3](#).

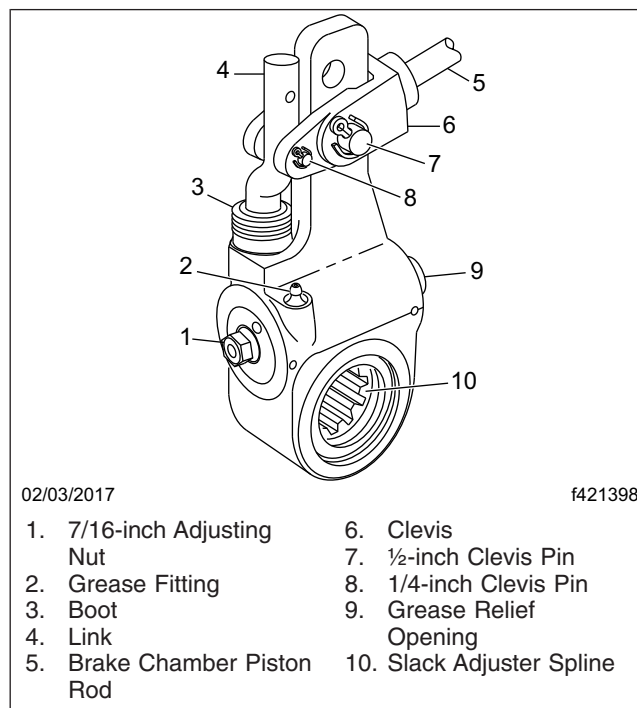

Fig. 22.1, Gunite Automatic Slack Adjuster

- Inspect slack adjuster boots, if equipped, for cuts or tears.
- Inspect anchor straps, if equipped, for damage.
- Look for worn clevis pins on brake chamber pushrods.
- Look for missing or damaged cotter pins on the clevis pins.
- Ensure chamber piston rods are in line with the slack adjusters.

Wheel and Tire Inspection

Walk around the vehicle and visually inspect each wheel and tire assembly.

Pre- and Post-Trip Inspections and Maintenance

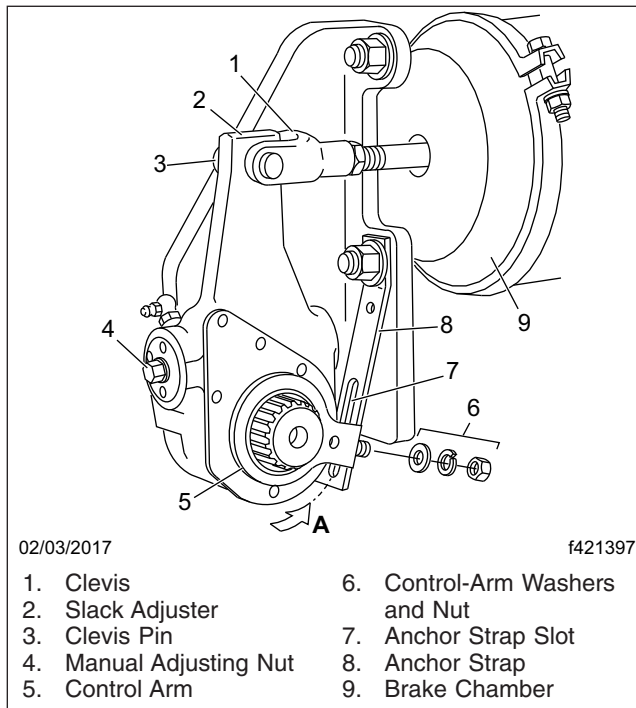

Fig. 22.2, Haldex Automatic Slack Adjuster

IMPORTANT: Wheel covers decrease drag force as a vehicle moves, thereby improving fuel efficiency. If replacement of a wheel cover is necessary, the replacement cover must meet or exceed the drag reduction performance of the originally installed cover in order to maintain compliance with greenhouse gas and fuel efficiency regulations.

1. If the vehicle was originally equipped with wheel covers, ensure all wheel covers are present. Inspect wheel covers for damage or wear. Remove wheel covers from rear drive wheels, if equipped, prior to inspecting the tires and wheel components.

NOTE: During wheel cover installation, ensure the V-notch in the liner inner retaining ring is centered on the valve stem. The inner and outer retaining rings should be uniformly aligned to each other and to the wheel rim. The outer retaining ring of the liner is equipped with two canvas flaps. When installing the face cover, make sure the cover retaining ring is inserted between the two canvas flaps on the liner outer retaining ring so that the Velcro strips line up between the face cover and the liner. Make

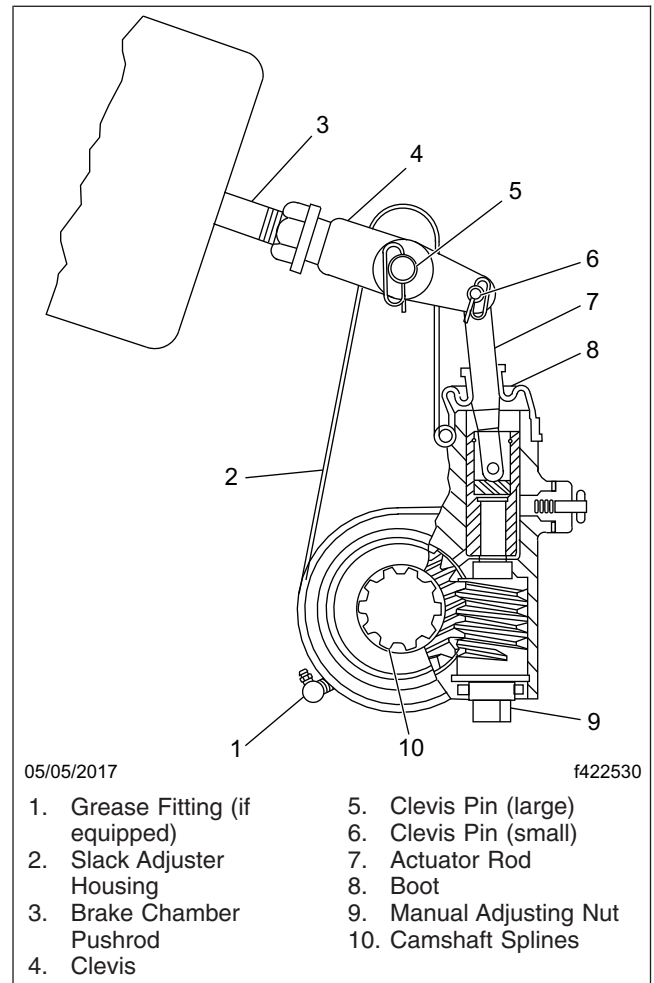

Fig. 22.3, Meritor Automatic Slack Adjuster

certain the detachable view cover is centered on the face cover, and the Velcro strips are pressed firmly in place.

2. Inspect each tire for the following:
 - valve stem caps on every tire, screwed on finger-tight
 - bulges, cracks, cuts, and penetrations
 - oil contamination (petroleum derivatives will soften the rubber and destroy the tire)
 - tread depth—if tread is less than 4/32 inch (3 mm) on any front tire, or less than 2/32 inch (1.5 mm) on any rear tire, replace the tire
 - debris lodged between dual tire sets

Pre- and Post-Trip Inspections and Maintenance

IMPORTANT: Low-rolling resistance (LRR) tires minimize wasted energy as a tire rolls, thereby decreasing rolling effort and improving fuel efficiency. If tire replacement is necessary, replacement tires must meet or have less rolling resistance than the originally installed tires in order to maintain compliance with greenhouse gas and fuel efficiency regulations.

Contact your tire manufacturer/supplier to determine the rolling resistance of the originally installed tires. Visit www.epa.gov/smartway for additional information and resources.

3. Check tire inflation.

For inflation pressures and maximum loads, see the tire manufacturer's guidelines. Inflate the tires to the applicable pressures if needed.

If a tire has been run flat or under-inflated, check the wheel and tire for damage before adding air.

Keep compressed air reservoirs and lines dry during tire inflation. Use well-maintained inline moisture traps and service them regularly.

WARNING

Do not operate the vehicle with underinflated or overinflated tires. Incorrect inflation can stress the tires and make the tires and rims more susceptible to damage, possibly leading to rim or tire failure and loss of vehicle control, resulting in serious personal injury or death.

NOTICE

A weekly pressure loss of 4 psi (28 kPa) or more in a tire may indicate damage. The tire should be inspected and, if necessary, repaired or replaced by a qualified tire service facility.

IMPORTANT: The load and cold inflation pressure must not exceed the rim or wheel manufacturer's recommendations, even though the tire may be approved for a higher load inflation. Consult the rim or wheel manufacturer for the correct tire inflation pressure for the vehicle load.

4. Examine each rim and wheel component.

- 4.1 Remove all dirt and debris from the assembly. Rust streaks or metal build-up around stud holes, or out-of-round or worn stud holes, may be caused by loose wheel nuts.

WARNING

Have any worn or damaged wheel components replaced by a qualified person using the wheel manufacturer's instructions and the wheel industry's standard safety precautions and equipment. Otherwise a vehicle or workshop accident could occur, possibly resulting in serious personal injury or death.

- 4.2 Inspect for broken, cracked, badly worn, bent, rusty, or sprung rings and rims.

NOTICE

Use the recommended torque values and follow the proper tightening sequence. Insufficient wheel nut torque can cause wheel shimmy, resulting in wheel damage, stud breakage, and extreme tire tread wear. Excessive wheel nut torque can break studs, damage threads, and crack discs in the stud hole area.

- 4.3 Make sure all wheel nuts are tightened. If tightening is necessary, use the tightening pattern in [Fig. 22.4](#) to initially tighten the flange nuts to 50 to 100 lbf-ft (68 to 136 N·m). Then tighten the flange nuts to 450 to 500 lbf-ft (610 to 678 N·m).

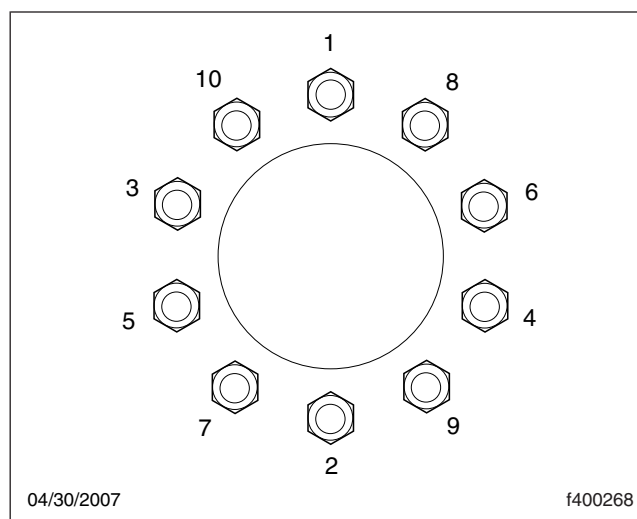

Fig. 22.4, Tightening Pattern, 10-Hole Wheels

Pre- and Post-Trip Inspections and Maintenance

5. Inspect the outboard side of all wheel hubs and the hub oil seal area on the inboard side of each wheel for signs of oil leakage. If any oil is found on wheel and tire or brake components, remove the vehicle from service until the leak has been fixed.

If needed, fill the hubs to the level indicated on the hub cap. See **Group 35** of the *M2 Plus Maintenance Manual* for recommended lubricants.

6. Check that mud flaps are undamaged and hang 10 inches (25.4 cm) or less from the ground.

Saddle Tank Areas Inspection

WARNING

When draining the air reservoir, do not look into the air jets or direct them toward anyone. Dirt or sludge particles may be in the airstream and could cause injury.

NOTICE

If the water drained from the air reservoirs is cloudy or oily, it may indicate a problem with the compressor. If oil is allowed to contaminate the air dryer, it will not remove the water from the air brake system, which could adversely affect braking.

1. Drain the brake system air reservoirs (reservoirs without automatic drain valves only).

WARNING

Never operate the engine with the fuel tank shutoff valves partially closed. This could damage the fuel pump, causing sudden loss of engine power, possibly resulting in serious personal injury due to reduced vehicle control.

2. Ensure fuel tanks are secured to their mounting brackets and that the mounting brackets are secured to the frame.
If equipped with fuel tank shutoff valves, be sure the valves are fully open.
3. Inspect visible frame rails for missing bolts, shiny areas, or rust streaks. Check all visible crossmembers for damage or signs of looseness.
4. Inspect visible components of the exhaust system to ensure connections are tight.

Inspect upstream of the aftertreatment device (ATD), if equipped, for cracking or signs of leaks, such as soot trails. Inspect downstream of the ATD for signs of exhaust leaks, such as blistering or warping of nearby components.

Engine Compartment Inspection

1. Check the ground underneath the engine for fuel, oil, or coolant leaks.
2. Inspect the air intake system for leaks or damage.

NOTICE

Failure to maintain a sealed air intake system could allow the entry of dirt and contaminants into the engine. This could adversely affect engine performance and result in engine damage.

- 2.1 Push the reset button on the air intake restriction indicator, if equipped.

NOTE: The air intake restriction indicator may be located on the air intake or the dash.

- 2.2 Check the air intake duct from the air cleaner to the engine intake. Make sure the duct components are secure and airtight.

3. Check the engine oil level.

NOTICE

Operating the engine with the oil level below the minimum fill (or "add") mark or above the maximum fill (or "full") mark could result in engine damage.

- 3.1 Check the oil level with the vehicle parked on a level surface. See the engine manufacturer's guidelines for engine shutdown time requirements prior to checking the oil level.

IMPORTANT: Use CJ-4 engine oil with less than 1% sulfated ash. Failure to use CJ-4 oil may void the warranty on emission aftertreatment components.

- 3.2 If the oil level is at or below the minimum fill (or "add") mark on the dipstick, add enough oil to maintain the level between

Pre- and Post-Trip Inspections and Maintenance

the minimum and maximum fill marks. See the engine operation manual for recommended lubricants.

4. Check the power steering reservoir fluid level.

The power steering fluid level should be between the MIN COLD mark and the middle mark just above it. See **Fig. 22.5**. If needed, fill the reservoir with automatic transmission fluid that meets Dexron III or TES-389 specifications.

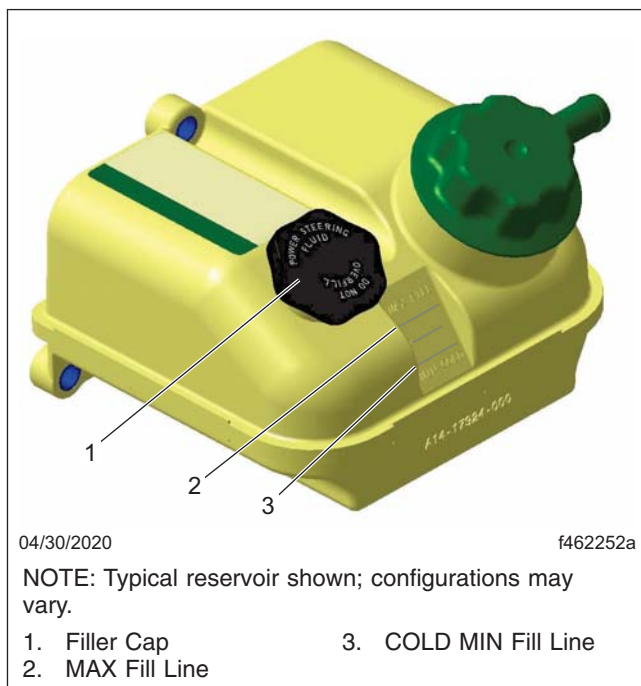

Fig. 22.5, Power Steering Fluid Reservoir

NOTICE

Low coolant could result in engine overheating, which could cause engine damage.

IMPORTANT: The surge tank must be cool to check the coolant level.

5. Check the engine coolant level in the radiator surge tank. See **Fig. 22.6**.

NOTICE

Coolant must be filled to the COLD MAX line of the surge tank. Low coolant could result in engine overheating, which could cause engine damage.

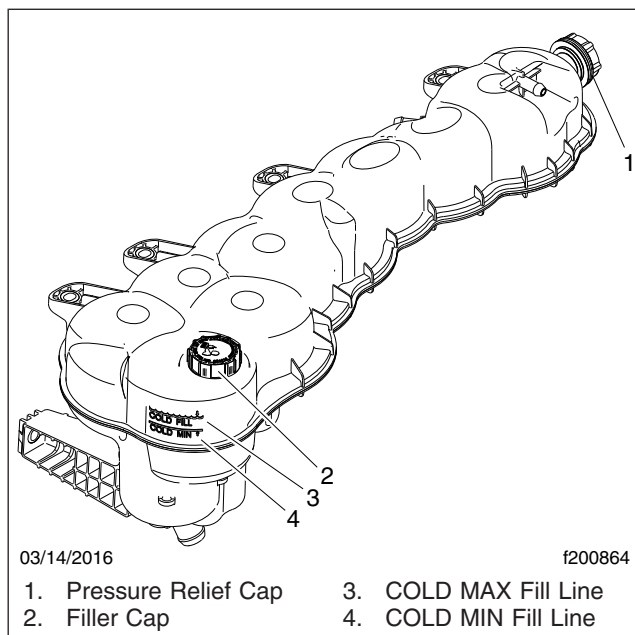

Fig. 22.6, Coolant Surge Tank

5.1 If the coolant is low, fill the surge tank to the MAX line with a 50/50 mixture of water and the type of antifreeze currently installed in your vehicle.

5.2 If the surge tank was empty, start the engine after refilling and check the level again when the engine is at operating temperature.

6. Inspect visible engine wiring for damage or looseness. Check for loose wiring, chafed insulation, and damaged or loose hold-down clamps.
7. Inspect visible frame rails for missing bolts, shiny areas, or rust streaks.

Cab Inspection

1. Push the reset button on the dash-mounted air intake restriction indicator, if equipped.
2. With the ignition switch in the OFF position, check the air-pressure warning system.

NOTE: The low-air warning buzzer only works when the park brake is released. The low-air warning buzzer is silenced when the park brake is set.

Pre- and Post-Trip Inspections and Maintenance

- 2.1 If not previously drained, drain the air reservoirs using moderate brake applications until pressure in both reservoirs is less than 70 psi (483 kPa).
- 2.2 Turn the ignition to the ON position. The ICU will complete a full gauge sweep and bulb check, and a low-air warning buzzer will sound. Ensure the low air pressure lamp (BRAKE AIR) remains illuminated and a low-air warning buzzer continues to sound after the gauge sweep is complete.
3. Check air governor cut-in and cut-out pressures.
 - 3.1 Start the engine and ensure the BRAKE AIR lamp goes out and the buzzer silences when pressure reaches approximately 70 psi (483 kPa) in both air reservoirs.

The air governor should cut out at approximately 120 psi (827 kPa). For vehicles with an optional dryer reservoir module (DRM), the cut-out pressure is approximately 130 psi (896 kPa).
 - 3.2 With the engine idling, apply the brake pedal several times. The air governor should cut in when pressure in the primary air reservoir (top air gauge) reaches approximately 100 psi (689 kPa).
4. Check air pressure build-up time.
 - 4.1 With the air system fully charged, make one full brake application and note the air pressure reading on the primary air gauge.
 - 4.2 Further reduce air pressure using moderate brake applications, then run the engine at governed rpm.
 - 4.3 Note the time that the pressure reaches the previously noted reading on the primary air gauge, then note the time that the air pressure reaches cut-out pressure.
 - 4.4 If it takes longer than 30 seconds to reach cut-out pressure after the primary air gauge passes the previously noted pressure (noted after one full brake application), eliminate any leaks or replace the air compressor before operating the vehicle.
5. Check air leakage in the system.

- 5.1 With the parking brake applied, the transmission out of gear, and the air system fully charged, release the service brakes and shut down the engine.
- 5.2 Wait one minute and note the air pressure drop in psi (kPa) per minute from the primary air reservoir.

If the pressure drop exceeds the limits shown in **Table 22.1**, eliminate any leaks before operating the vehicle.

6. Check the air pressure reserve.

With the engine still off, make one full brake application and observe the pressure drop on the primary air gauge. If pressure drops more than 25 psi (172 kPa), eliminate any leaks before operating the vehicle.

Description	Maximum Allowable Air Leakage	
	Pressure Drop: psi (kPa) Per Minute	
	Released	Applied
Truck or Tractor Only	2 (14)	3 (21)
Truck or Tractor w/Single Trailer	3 (21)	4 (28)
Truck or Tractor w/Two Trailers	5 (35)	6 (42)

Table 22.1, Maximum Allowable Air Leakage

WARNING

When cleaning windshields and windows, always stand on the ground or on a secure ladder or platform. Use a long-handled window cleaner. Do not use the cab steps, tires, fenders, fuel tanks, engine, or under-hood components to access the windshield or windows. Doing so could cause a fall and result in an injury.

7. Inspect the mirrors, window glass, and windshield for cracks or other damage.
8. Ensure that the horn, windshield wipers, and windshield washers are operating properly. These devices must be in good working order for safe vehicle operation.
9. Ensure the heater and defroster are operating properly.
10. Check the operation of all interior lights.
 - 10.1 Turn on the headlamps and leave them on. If equipped, ensure all gauge bulbs illuminate. If equipped, ensure ICU screens illuminate.

Pre- and Post-Trip Inspections and Maintenance

- 10.2 Ensure all equipped driver control switches illuminate and verify the interior cab lights controlled by these switches illuminate.
- 10.3 Ensure both turn signal indicators illuminate when the turn signal switch is activated.
11. Check the operation of all exterior lamps manually or, if equipped, by using either the LIGHT TEST switch on the dash or the Lamp Check button on the key fob.
 - 12.4 Exit the cab and check that all exterior lamps and reflectors are clean and intact.
 - 12.5 Check that the brake lamps, tail lamps, headlamps, turn signals, marker lamps, identification lamps, and clearance lamps are working properly.
13. To check the exterior lamps using the dash LIGHT TEST switch, shown in [Fig. 22.8](#), or key fob Lamp Check button, shown in [Fig. 22.9](#):
 - 13.1 Make sure the parking brake is set.

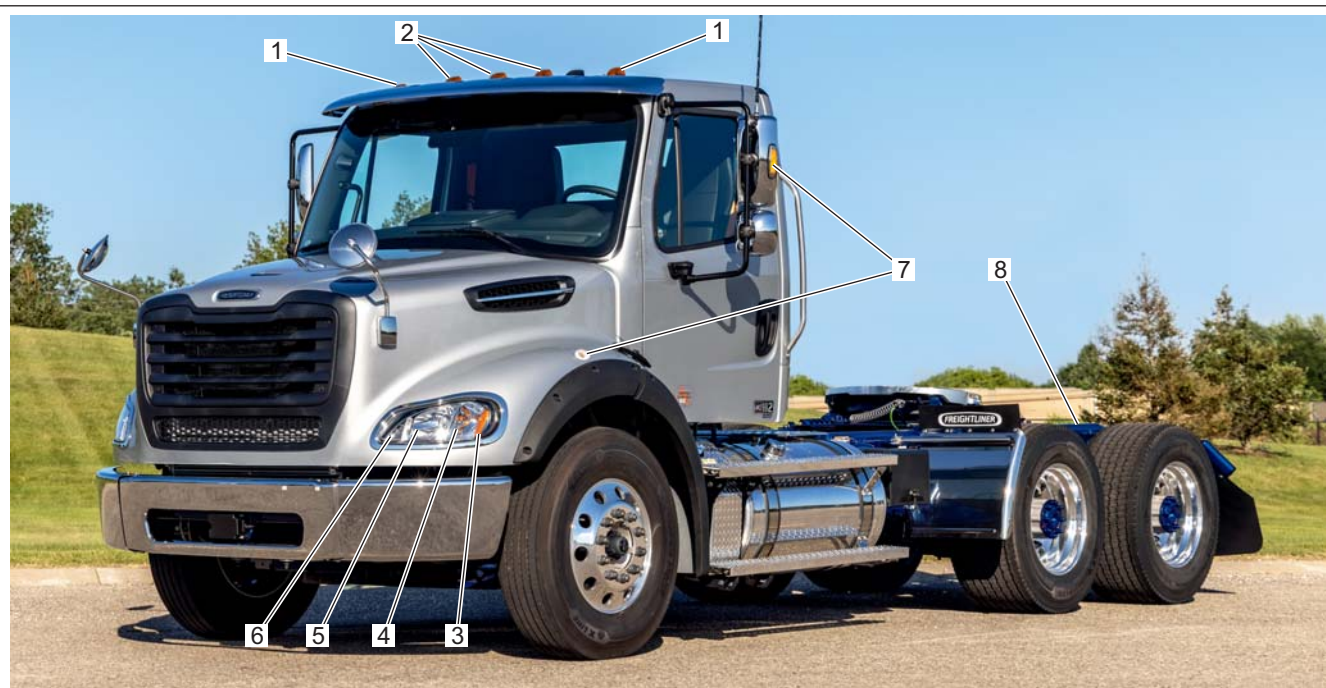

02/01/2023

f546503b

- | | |
|-------------------------|---|
| 1. Clearance Lamp | 6. Headlamp, High Beam |
| 2. Identification Lamps | 7. Side Marker Lamps |
| 3. Turn Signal | 8. Stop Lamps, Tail Lamps, Turn Signals, and Back-Up Lamp |
| 4. DRL/Accent Lamps | |
| 5. Headlamp, Low Beam | |

Fig. 22.7, Exterior Lights

12. To check exterior lamps manually:
 - 12.1 Turn the ignition switch to the ACC or ON position.
 - 12.2 Make certain the parking brake is set.
 - 12.3 Activate the high-beam headlamps and hazard warning lamps.
- NOTE: Factory settings have groups of lamps activate sequentially up to 100 times or until manually stopped.
- 13.2 Press either the LIGHT TEST switch or Lamp Check button to begin the pretrip light inspection. If equipped, groups of lamps will cycle on and off in the following sequence:

Pre- and Post-Trip Inspections and Maintenance

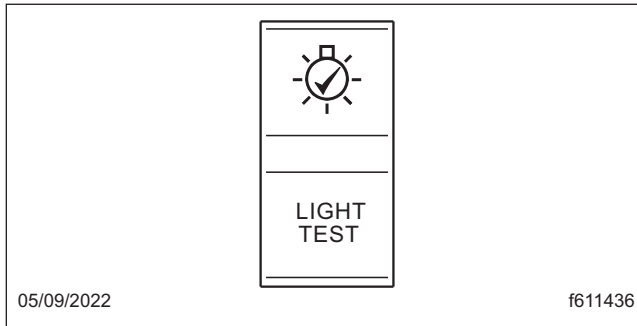
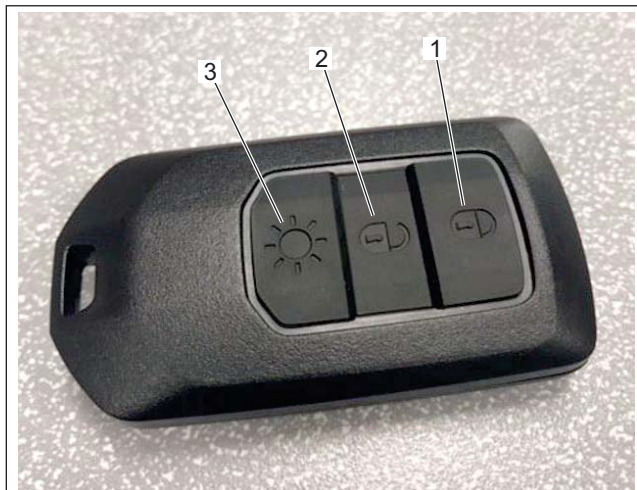

Fig. 22.8, Pretrip Light Test Switch



1. Door Lock 2. Door Unlock 3. Lamp Check

Fig. 22.9, Key Fob

- Group 1: Always ON: marker lamps, clearance lamps, tail lamps, licence plate lamp
- Group 2: Low beam headlamps
- Group 3: High beam headlamps and stop lamps
- Group 4: Backup lamps and daytime running lamps
- Group 5: Front and rear fog lamps
- Group 6: Turn signals and utility lamps

NOTE: LED accent lighting turns off when the high beam headlamps turn on.

- 13.3 Walk around the truck and check that the lamps are working properly.

- 13.4 Verify that all exterior lights and reflectors are clean and intact.
- 13.5 The pretrip light inspection can be stopped by:
- releasing the parking brake;
 - Pressing either the LIGHT TEST switch on the dash or the Lamp Check button on the key fob.

14. Inspect the seat belts and tether belts.

WARNING

Inspect and maintain seat belts. When any part of a seat belt system needs replacement, the entire seat belt must be replaced, both retractor and buckle side. Any time a vehicle is involved in an accident, and the seat belt system was in use, the entire vehicle seat belt system must be replaced before operating the vehicle. Do not attempt to modify the seat belt system; doing so could change the effectiveness of the system. Failure to replace worn or damaged seat belts, or making any modifications to the system, may result in personal injury or death.

- 14.1 Check the web for fraying, cuts, extreme dirt and dust, or for severe fading from exposure to sunlight, especially near the buckle latch plate and in the D-loop guide area.
- 14.2 Check operation of the buckle, latch, Komfort Latch or Sliding Komfort Latch (if equipped), web retractor, and upper seat belt mount on the door pillar. Check all visible components for wear or damage.
- 14.3 Check the seat belt and tether belt connection points and tighten any that are loose.

WARNING

Never fill fuel tanks to more than 95 percent of their liquid capacity. This could make them more likely to rupture from impact, possibly causing fire and resulting in serious personal injury or death by burning.

Do not mix gasoline or alcohol with diesel fuel. This mixture could cause an explosion, possibly resulting in serious personal injury or death. Do not fill the fuel tanks in the presence of sparks,

Pre- and Post-Trip Inspections and Maintenance

open flames, or intense heat. These could ignite the fuel, possibly causing severe burns.

IMPORTANT: Use ultralow-sulfur diesel (ULSD) with 15 ppm sulfur content or less. Failure to use ULSD fuel may void the warranty on emission components.

15. Check the fuel level in the fuel tank(s). To keep condensation to a minimum, fuel tanks should be filled at the end of each day.
16. Adjust the rearview and down view mirrors as necessary.
17. Test the service brakes.
 - 17.1 With the engine running and air system fully charged, set the parking brake.
 - 17.2 Put the vehicle in the lowest gear and gently attempt to move it forward. The vehicle should not move.

If the vehicle moves, the parking brakes are not operating correctly and must be repaired before the vehicle is operated.

18. Test the backup alarm.
 - 18.1 Release the parking brake and put the transmission in reverse.
 - 18.2 Move the vehicle slightly backward to ensure that the backup alarm is operating correctly.

Weekly Post-Trip Inspections and Maintenance

Engine Compartment Inspection



WARNING

Washer fluids may be flammable and poisonous. Do not expose washer fluid to an open flame or any burning material, such as a cigarette. Always comply with the washer fluid manufacturer's recommended safety precautions.

1. Check the windshield washer reservoir fluid level. The reservoir is usually located near the right-hand frame rail. See [Fig. 22.10](#).
2. After resetting the air intake restriction indicator during the daily pre-trip inspection, check the indicator again with the engine off.

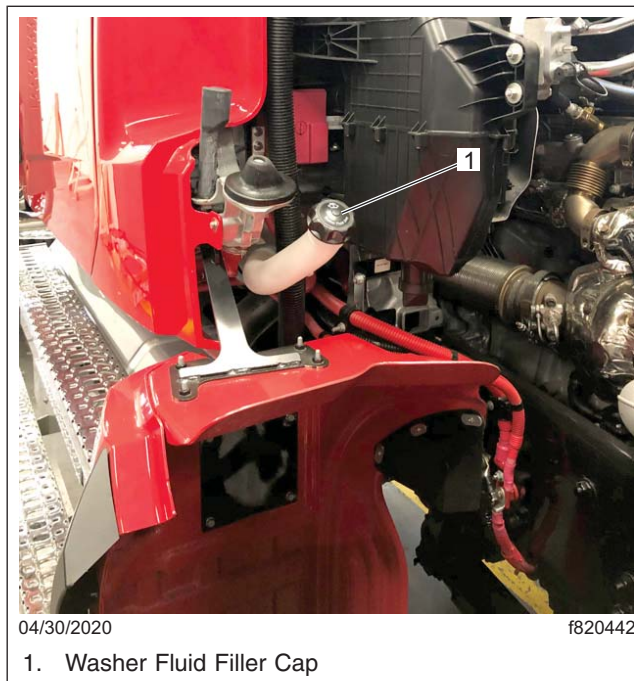

Fig. 22.10, Windshield Washer Reservoir

- 2.1 Check an indicator with graduations to see if air restriction exceeds the value shown in [Table 22.2](#).

Check a go/no-go indicator without graduations to see if the colored bar shows through the clear window.

Air Intake Maximum Restriction Values (inH ₂ O)	
Engine Make	GHG14, GHG17, and GHG21 Engines
Cummins	25
Detroit	18

Table 22.2, Air Intake Maximum Restriction Values (inH₂O)

- 2.2 If air restriction exceeds the maximum allowable value, operate the vehicle for one more day, making sure not to run the engine over rated rpm. Refer to the engine operation manual for more information on rated rpm for your engine.
- 2.3 If air restriction exceeds the maximum value again, replace the air cleaner. For instructions, refer to **Group 09** of the *M2 Plus Workshop Manual*.
3. Inspect water evacuation components.

Pre- and Post-Trip Inspections and Maintenance

- 3.1 Inspect the vacuator valve(s) installed on the hood interior and air cleaner. Make sure the lips of each valve are undamaged and pliable, free of debris, and remain closed during inspection. See [Fig. 22.11](#).
- 3.2 Inspect the rain tray installed at the base of the windshield. Ensure that the seal on the forward edge of the rain tray is in good condition.
- 3.3 Inspect the drain hoses installed on the rain tray. Both hoses should be securely attached to the rain tray and direct water down the aft side of the front fenders.

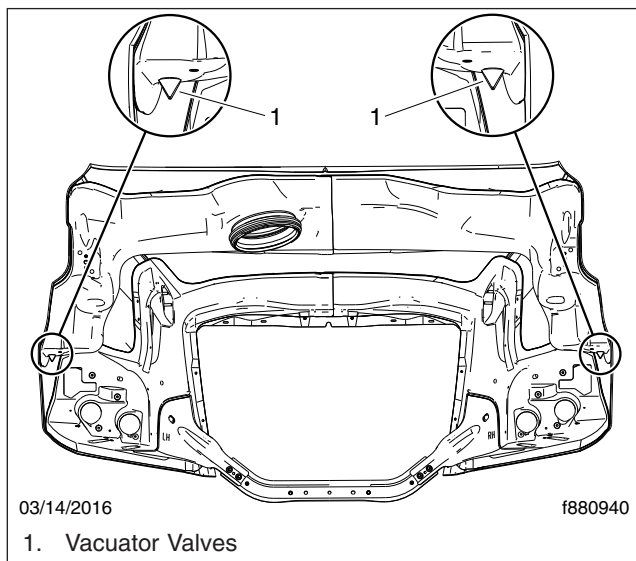

Fig. 22.11, Hood Vacuator Valves (hood interior shown)

4. If the vehicle is equipped with an automatic transmission, examine the dipstick to check the automatic transmission fluid level.
5. Check for water in the fuel/water separator, if equipped.

IMPORTANT: When draining fluid from a fuel/water separator, drain the fluid into an appropriate container and dispose of it properly. Many jurisdictions now issue fines for draining fuel/water separators onto the ground.

- 5.1 Place a suitable container under the fuel/water separator.

NOTE: A hose may be used to direct water into the container. On older DAVCO models, the drain valve has a 1/2-inch (12.7-mm) pipe with threads. Use a hose with a 1/2-inch pipe thread to fit correctly and open the drain valve by turning it one-quarter revolution. On new DAVCO models, the drain valve has a 3/4-inch (19-mm) slip-on hose connection; pipe threads are no longer used. Open the drain valve by turning it one to one-and-a-half revolutions.

- 5.2 If the engine is equipped with a built-in water separator, loosen the drain valve, and allow the water to run out. Close the drain valve, taking care not to overtighten it.
- 5.3 *Detroit/Racor Models:* Turn the drain plug counterclockwise to open it.
DAVCO Models: Remove the vent cap and open the drain. See [Fig. 22.12](#).
- 5.4 Stop draining fluid when fuel begins to drain out.
Detroit/Racor Models: turn the drain plug clockwise to close it.
DAVCO Models: close the drain valve. Install and hand-tighten the vent cap.
6. Inspect the steering components.
 - 6.1 Inspect tie rods, steering arms, and the drag link for signs of looseness (i.e., shiny spots or rust tracks).
 - 6.2 Check the steering gear mounting bolts and pitman arm nut, if equipped, for signs of looseness. See [Fig. 22.13](#).
 - 6.3 Check the drag link nuts for missing cotter pins.
 - 6.4 Inspect the steering intermediate shaft and end yokes for excessive looseness or other damage.

NOTICE

Do not drive with a drive belt that is visibly worn or damaged. If it fails, the lack of coolant flow could rapidly cause damage to engine components.

Pre- and Post-Trip Inspections and Maintenance

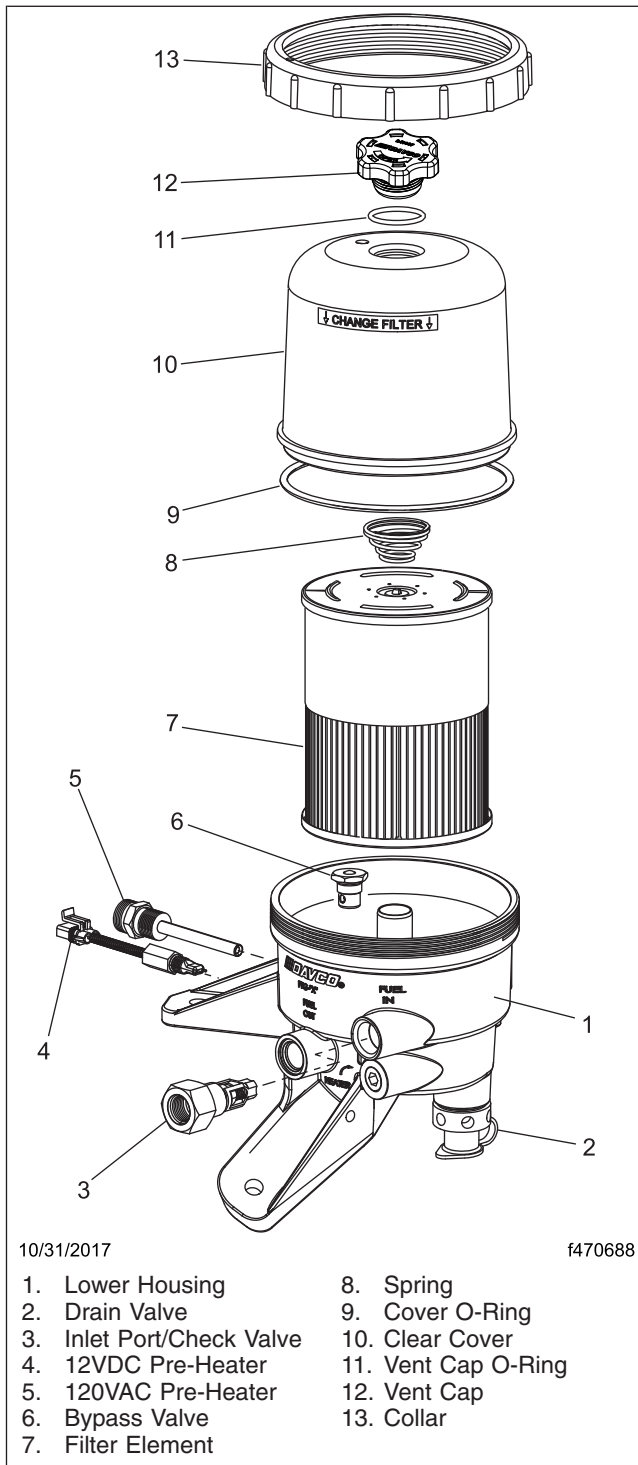

Fig. 22.12, DAVCO Fuel Pro 485

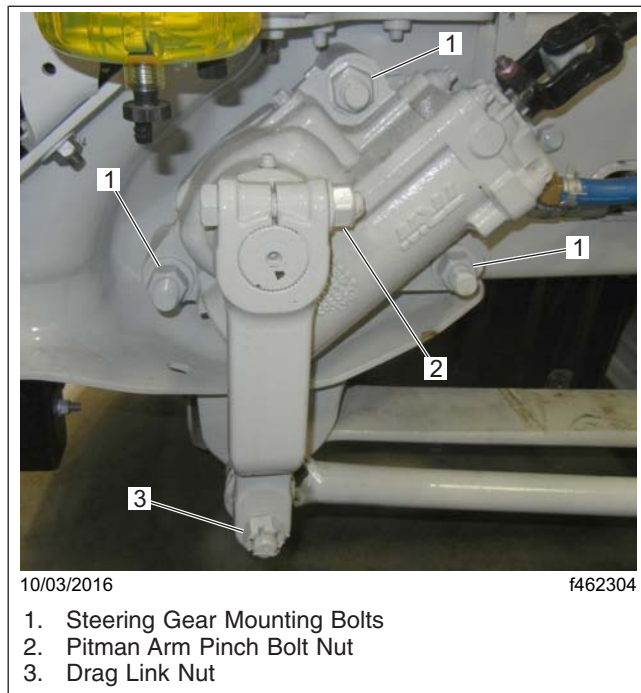

Fig. 22.13, Steering Gear Fasteners

7. Inspect the serpentine drive belts for signs of glazing, frayed edges, breaks, cracks, or oil contamination.

Monthly Post-Trip Inspections and Maintenance

Brake Component Inspection

Walk around the vehicle and inspect brake system components for visible damage.

NOTE: Some vehicles may be equipped with a brake check valve on the dash, which allows the driver to set the service brakes and exit the vehicle to check the brake system for leaks. The parking brakes must be applied before the brake check valve will function.

1. Inspect all visible brake system components for missing fasteners or signs of looseness, such as rust tracks.

NOTICE

If the external breather tube or breather cap is missing or incorrectly installed, road dirt and debris can adversely affect the operation of the

Pre- and Post-Trip Inspections and Maintenance

brake chamber. Once inside of the chamber, dirt and debris can cause the internal parts of the chamber to deteriorate faster.

2. Inspect the exterior surfaces of brake chambers for damage. Make sure that breather holes are open and free of debris.

NOTE: Do not route air brake lines on top of anything likely to be stepped on.

3. Inspect air brake lines for dents, swelling, kinks, twisting, abrasion, and damage, especially near moving parts.
4. Inspect flex air lines for deterioration or signs of abrasion.
5. Inspect for cracked, worn, or oil-contaminated brake linings and brake drums (or rotors).
6. Check the thickness of the brake linings. Replace brake linings on all brake assemblies on the axle if any brake linings are worn to less than approximately 1/4 inch (6.4 mm) at the thinnest point.

Saddle Tank Areas Inspection

WARNING

When draining the air reservoir, do not look into the air jets or direct them toward anyone. Dirt or sludge particles may be in the airstream and could cause injury.

NOTICE

If the water drained from the air reservoirs is cloudy or oily, it may indicate a problem with the compressor. If oil is allowed to contaminate the air dryer, it will not remove the water from the air brake system, which could adversely affect braking.

1. Drain the brake system air reservoirs (reservoirs with automatic drain valves only).

NOTE: Battery locations vary between vehicles.

2. Inspect the batteries.

WARNING

Battery posts, terminals, and related accessories contain lead and lead compounds, chemicals known to the State of California to cause cancer

and reproductive harm. To prevent possible personal injury, always wash your hands after handling battery parts and related accessories.

- 2.1 Remove the battery box cover and inspect all visible battery cables for loose wiring or damage.
- 2.2 Check that the battery hold-down is secure.

IMPORTANT: Aerodynamic components decrease drag force as a vehicle moves, thereby improving fuel efficiency. If replacement of an aerodynamic component is necessary, replacement components must meet or exceed the drag reduction performance of the originally installed component in order to maintain compliance with greenhouse gas and fuel efficiency regulations.

3. Inspect the following aerodynamic components, if equipped, for structural damage, cracks, or wear.
 - Chassis fairings
 - Roof fairing/deflector
 - Side skirts
 - Cab/sleeper extenders
 - Battery access cover

Engine Compartment Inspection and Adjustments

IMPORTANT: If replacement of the hood or bumper is necessary, the replacement component must meet or exceed the drag reduction performance of the originally installed item in order to maintain compliance with greenhouse gas and fuel efficiency regulations.

NOTE: Anytime a hood is adjusted, removed, or reinstalled, the headlamp aim should be checked.

1. Inspect the bumper and hood for structural damage, cracks, or wear.
2. Check the hydraulic clutch reservoir, if equipped. If necessary, add DOT 4 brake fluid.
3. Inspect the radiator and heater hoses, including the clamps and support brackets.

Pre- and Post-Trip Inspections and Maintenance

- 3.1 Inspect the radiator and charge air cooler for damage and accumulated debris. Straighten bent or damaged fins to permit airflow across all areas of the cores.

NOTE: When traveling through areas of high insect concentration, it may be necessary to clean the exterior of the radiator or the charge air cooler core as often as every 200 miles (320 km).

- 3.2 Make sure the radiator inlet and outlet hoses are pliable and are not cracking or ballooning.
- 3.3 Make sure the heater hoses are pliable and are not cracking or ballooning.
- 3.4 Tighten hose clamps as necessary.

IMPORTANT: Do not overtighten hose clamps, as hose life can be adversely affected.

- 3.5 Ensure hose support brackets are securely fastened. Make sure hoses are not located near sources of wear, abrasion, or high heat.

IMPORTANT: When replacing hoses, install service-type knitted or braided yarn-reinforced neoprene hose. Extended-service-life silicone hoses may also be used. See the Alliance Parts Catalog at www.alliancebrandparts.com or contact your Freightliner Dealer.

4. Check the steering wheel for excessive play.
 - 4.1 Start the engine. With the front tires straight ahead, turn the steering wheel until motion is observed at the front wheels.
 - 4.2 Align a reference mark on the steering wheel to a rule, then slowly turn the steering wheel in the opposite direction until motion is again detected at the wheels.
 - 4.3 Measure the lash (free play) at the rim of the steering wheel. Excessive lash exists if steering wheel movement exceeds 2-1/4 inches (57 mm) with an 18-inch (450-mm) steering wheel.
 - 4.4 If there is excessive lash, check the steering system for wear or incorrect adjustment before operating the vehicle.

In an Emergency

Hazard Warning Lights	23.1
Fire Extinguisher	23.1
Fire in the Cab	23.1
Emergency Kit, Optional	23.1
Emergency Filter Replacement, Davco	23.1
Emergency Starting With Jumper Cables	23.3
Raising and Lowering a Vehicle	23.4
Front Towing Hookup With Removable Tow Hooks	23.5

In an Emergency

Hazard Warning Lights

The hazard warning light switch is located on the dash in what is referred to as the master module. See [Fig. 23.1](#). The hazard lights can be activated regardless of the ignition switch position.

To activate the hazard lights, push the center of the switch once. The switch will blink at the same rate that the hazard lights flash. Push the switch again to turn them off. All the turn signal lights on the vehicle and trailer, as well as the turn signal indicators in the ICU, flash simultaneously when the hazard lights are activated.



Fig. 23.1, Hazard Warning Switch

Fire Extinguisher

A fire extinguisher is located in the cab by the driver's door.

Fire in the Cab

The incidence of fire in heavy and medium-duty trucks is rare, according to data from the National Highway Traffic Safety Administration. Federal Motor Vehicle Safety Standard #302 limits the flammability of specified materials used inside the cab but, despite this, most materials can burn.

! WARNING

Do not allow flames, sparks, or any other heat sources (such as cigarettes or light bulbs) to contact materials in the cab. Any materials in the cab in contact with such heat sources could cause serious personal injury as well as damage to the vehicle.

In Case of a Cab Fire

As quickly as possible, bring the vehicle to a safe stop, apply the parking brake, turn off the ignition, and get out of the vehicle.

Emergency Kit, Optional

An optional emergency kit is located in the cab. The kit includes one or more of the following: a first aid kit, a reflective vest, a triangular reflector, a flare kit, and (on vehicles with a Davco fuel/water separator) a spin-on fuel filter element.

If there is an emergency while driving, cautiously pull off the road. Turn on the hazard warning lights. Place the flares and reflector along the side of the road to alert other drivers that an emergency situation exists.

! WARNING

Use extreme care when placing flares in emergency situations that involve exposure to flammable substances such as fuel. An explosion or fire could occur causing serious personal injury.

Emergency Filter Replacement, Davco

If the filter cover on the Davco fuel/water separator is broken, it will not be possible to operate the vehicle. A standard spin-on filter will correct this problem.

Refer to the Davco web site for additional information, www.davcotec.com.

To replace the filter on all Davco fuel/water separators, follow these procedures:

1. Drain the fuel into a suitable container until it is below the level of the filter collar. See [Fig. 23.2](#) for the model 382 fuel/water separator.

2. Remove the filter vent and vent seal.

NOTE: The filter vent and vent seal are not needed in the emergency replacement. They should be retained for later installation at the time when the filter cover is replaced.

3. Using a DAVCO collar wrench, shown in [Fig. 23.3](#), remove the clear cover and collar.

NOTE: Broken vent cap and collar warranty claims will not be accepted if any tool other than a DAVCO collar wrench, p/n 380134 or 382002,

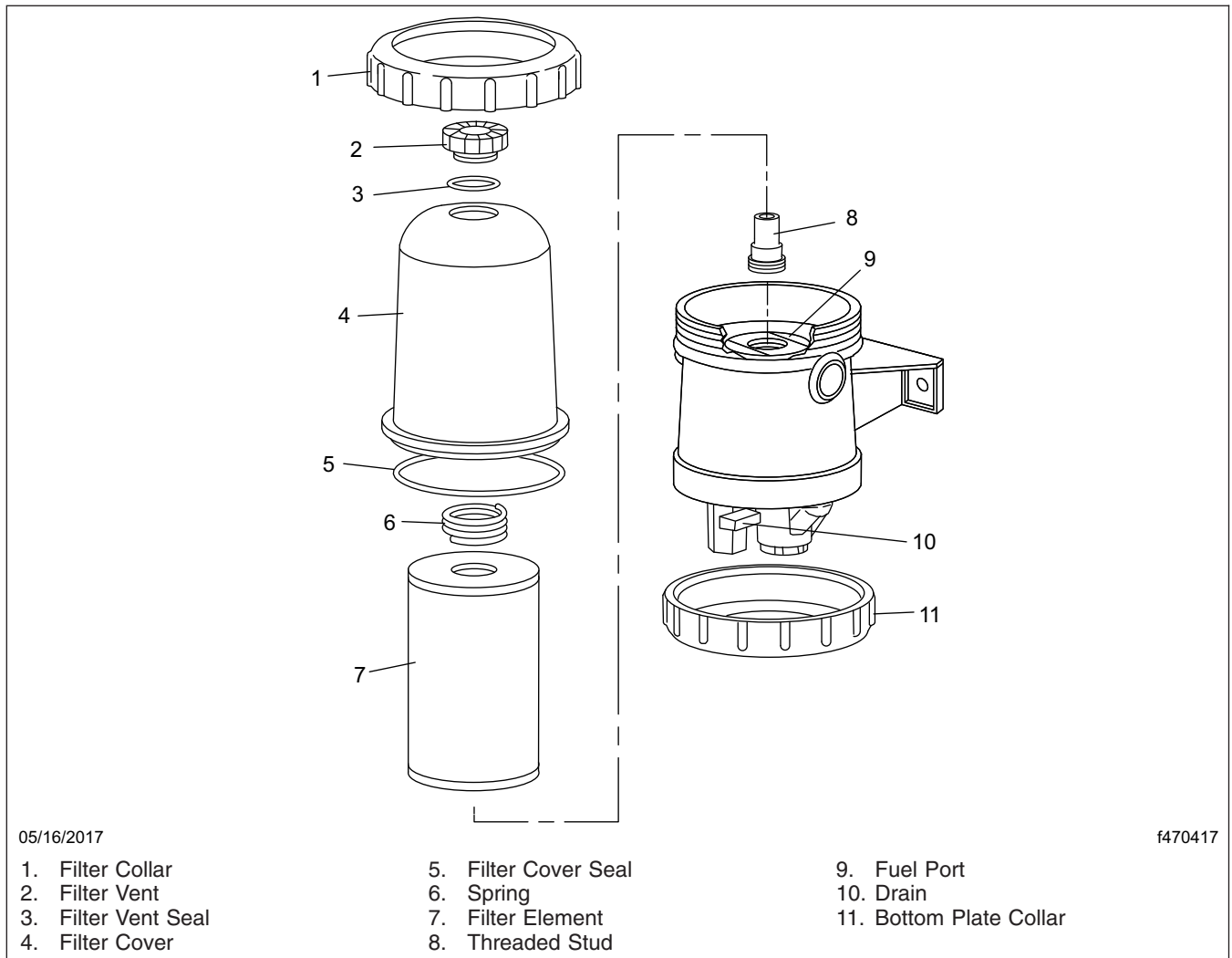

Fig. 23.2, Davco Model 382 Fuel/Water Separator

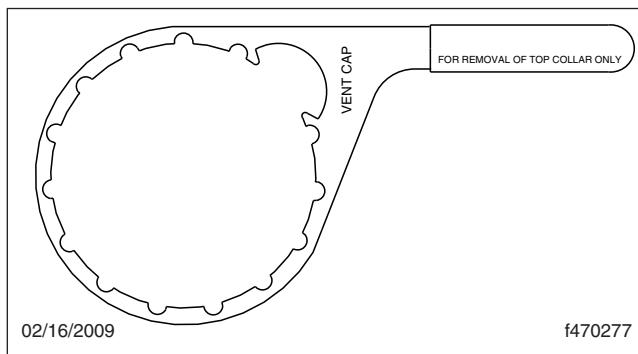

Fig. 23.3, DAVCO Collar Wrench

is used for removal. During installation, the vent

cap is to be **hand-tightened only**, not tightened with a wrench.

4. Remove the filter cover, filter cover seal and spring. Retain them for later assembly.
5. Remove the filter element and dispose of it properly.

NOTE: Remove the rubber grommet from the stud.

6. Install the standard engine spin-on filter (included in the emergency kit) on the threaded stud.
7. Install the filter cover, filter cover seal, and spring, as removed.

In an Emergency

8. Install the filter collar over the filter cover. Simultaneously apply downward pressure to the top of the clear cover until it is seated on the body of the lower housing and hand tighten the collar until it no longer spins freely. Using the collar wrench, tighten the cover 18 lbf-ft (24 N-m). This is equivalent to rotating the collar clockwise two or three additional ribs, depending on the specific filter model.
9. Start the engine and run it at increased rpm for one minute to purge air from the fuel lines.

Emergency Starting With Jumper Cables

When using jumper cables, follow the instructions below.

WARNING

Batteries release explosive gas. Do not smoke when working around batteries. Put out all flames and remove all sources of sparks or intense heat in the vicinity of the battery. Do not allow the vehicles to touch each other. Do not lean over the batteries when making connections, and keep all other persons away from the batteries. Failure to follow these precautions could lead to severe personal injury as a result of an explosion or acid burns.

NOTICE

Make sure both electrical systems are the same voltage. Electronic devices on both vehicles can be damaged when connected to a vehicle with a different operating voltage.

NOTE: On vehicles equipped with optional underhood jump start posts, connect to these posts instead of the batteries.

1. Apply the parking brakes and turn off the lights and all other electrical devices.
2. Remove the battery box cover.

NOTE: The battery box on an M2 Plus may be located in a variety of locations, including under the passenger seat, behind the side fairing, or behind the cab. If the battery box is located behind the side fairing, it can be accessed by opening the side fairing kick panel.

3. Connect the positive (+) jumper cable to the positive battery post or jump start post on the vehicle needing the jump start. See [Fig. 23.4](#), ref. A.

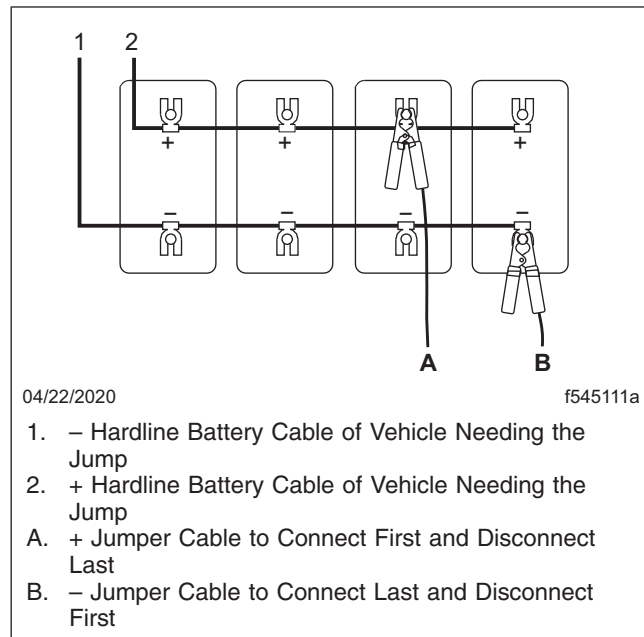

Fig. 23.4, Jumper Connections on Vehicle Needing Jump Start

4. Then connect the other end of the positive jumper cable to the positive battery or jump start post of the vehicle providing the jump start.

WARNING

Do the next step exactly as instructed and do not allow the clamps of one cable to touch the clamps of the other cable. Otherwise, a spark could occur near a battery, possibly resulting in severe personal injury from explosion or acid burns.

5. Connect one end of the negative jumper cable to the negative battery or jump start post of the vehicle providing the jump start.
6. Then connect (ground) the other end of the cable to a negative battery or jump start post on the vehicle needing a jump start. See [Fig. 23.4](#), ref. B.
7. Start the engine of the vehicle providing the jump start and let the engine run a few minutes to charge the batteries of the other vehicle.

8. Attempt to start the engine of the vehicle with the batteries receiving the charge. Do not operate the starter longer than 30 seconds, and wait at least two minutes between starting attempts to allow the starter to cool.
9. When the engine starts, let it idle a few minutes.

WARNING

Do the next step exactly as instructed and do not allow the clamps of one cable to touch the clamps of the other cable. Otherwise, a spark could occur near a battery, possibly resulting in severe personal injury from explosion or acid burns.

10. Disconnect the negative (grounded) jumper cable from the vehicle that needed the jump start. See [Fig. 23.4](#), ref. B.
11. Then disconnect the other end of the jumper cable from the vehicle that provided the jump start.
12. Disconnect the positive jumper cable from the positive battery or jump start post of the vehicle that provided the jump start.
13. Then disconnect the other end of the positive jumper cable from the positive battery or jump start post of the vehicle that received the jump start. See [Fig. 23.4](#), ref. A.
14. Install the battery box cover; be sure it is positioned properly before fastening the latches.

Raising and Lowering a Vehicle

Raising a Vehicle with Air Suspension

1. Park the vehicle on a level surface, set the parking brakes, and shut down the engine. Chock the tires.

WARNING

Remove the air from the suspension. Failure to remove the air from the suspension may cause the vehicle to move or shift on the jack stands as air pressure drains from the system; this could cause the vehicle to fall, resulting in damage to the vehicle, serious injury, or death.

2. Exhaust all air from the air suspension.

WARNING

Do not use bottle jacks to raise the vehicle. Always use floor jacks. Bottle jacks can slip, allowing the vehicle to fall, which could result in damage to the vehicle, serious injury, or death.

IMPORTANT: Only lift unloaded vehicles and vehicles disconnected from trailers. Unload vehicles with bodies (drilling rigs, mixers) as much as possible.

3. Place a floor jack under the axle housing, the clamp group, or the frame rail.

NOTICE

NOTICE: Do not place jack stands under any of the suspension components; doing so could cause suspension component damage. Jack stands can be placed at any point below the axle, including the differential area.

4. Raise the vehicle. Add additional jack stands, as needed, under the axles to support the vehicle.

Lowering a Vehicle with Air Suspension

WARNING

Do not use bottle jacks to raise the vehicle. Always use floor jacks. Bottle jacks can slip, allowing the vehicle to fall, which could result in damage to the vehicle, serious injury, or death.

NOTICE

NOTICE: Do not place jack stands under any of the suspension components; doing so could cause suspension component damage. Jack stands can be placed at any point below the axle, including the differential area.

1. Using the floor jack, raise the vehicle to remove any jack stands used to support the vehicle.
2. Slowly lower the vehicle to the ground.
3. Inflate the air suspension, and check for proper operation.

In an Emergency

Raising a Vehicle without Air Suspension

1. Park the vehicle on a level surface, set the parking brakes, and shut down the engine. Chock the tires.

WARNING

Do not use bottle jacks to raise the vehicle. Always use floor jacks. Bottle jacks can slip, allowing the vehicle to fall, which could result in damage to the vehicle, serious injury, or death.

IMPORTANT: Only lift unloaded vehicles and vehicles disconnected from trailers. Unload vehicles with bodies (drilling rigs, mixers) as much as possible.

2. Place a floor jack under the axle housing, the clamp group, or the frame rail.

NOTICE

NOTICE: Do not place jack stands under any of the suspension components; doing so could cause suspension component damage. Jack stands can be placed at any point below the axle, including the differential area.

3. Raise the vehicle. Add additional jack stands, as needed, to support the vehicle.

Lowering a Vehicle without Air Suspension

WARNING

Do not use bottle jacks to raise the vehicle. Always use floor jacks. Bottle jacks can slip, allowing the vehicle to fall, which could result in damage to the vehicle, serious injury, or death.

NOTICE

NOTICE: Do not place jack stands under any of the suspension components; doing so could cause suspension component damage. Jack stands can be placed at any point below the axle, including the differential area.

1. Using the floor jack, raise the vehicle to remove any jack stands used to support the vehicle.

2. Slowly lower the vehicle to the ground.

Front Towing Hookup With Removable Tow Hooks

NOTICE

Towing the truck from the front and removing all of the drivelines is the approved method for towing DTNA products. Towing any other way is not preferred.

DANGER

When working on the vehicle, shut down the engine, set the parking brake, and chock the tires. Before working under the vehicle, always place jack stands under the frame rails to ensure the vehicle can not drop. Failure to follow these steps could result in serious personal injury or death.

WARNING

Do not tow an unbraked vehicle if the combined weight of both vehicles is more than the sum of the gross axle weight ratings (GAWR) of the towing vehicle. Otherwise brake capacity will be inadequate, which could result in personal injury or death.

Use of Tow Hooks

Tow hooks are not designed for on-road towing of the vehicle, but to recover and move the vehicle to a position where it can be hooked up properly for front towing.

NOTICE

When using tow hooks to move the vehicle, do not pass a sling (for example, a rope or chain) from one hook to another. Known as reeving, this practice is *not* permissible in most industrial applications of towing and hoisting. Reeving can overload the hooks and result in damage to the vehicle. See [Fig. 23.5](#).

1. Disconnect the battery ground cables.

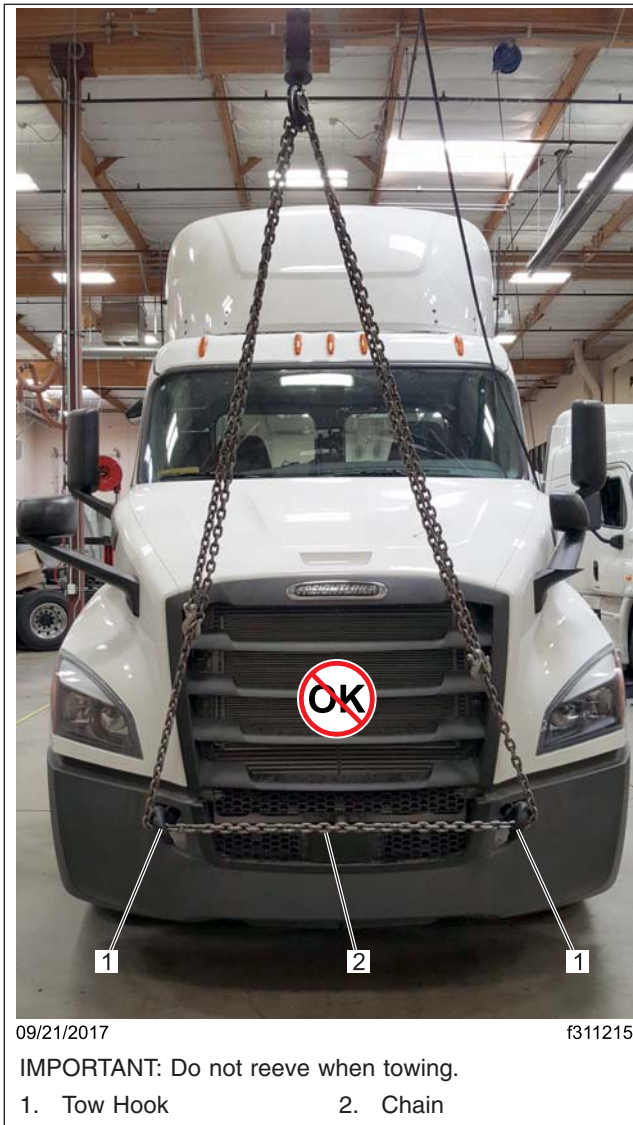

Fig. 23.5, Reeving

NOTICE

Failure to protect the frame rails from the chains could cause damage, leading to eventual frame failure.

2. On dual drive axles, if the vehicle is to be lifted and towed, chain the forward rear-axle assembly to the vehicle frame. Use protection to keep the chains from damaging the frame.
3. Open the hood. Remove the tow hooks, located behind the driver's-side bumper. See Fig. 23.6. Close and latch the hood.

NOTICE

New or ungreased tow hooks may be hard to install. Tow hooks that are not properly installed may be damaged or break.

4. Install the tow hooks onto the tow hook receivers through the tow hook holes in the bumper, rotating the hooks so the hook opening faces down. See Fig. 23.7. Pull the tow hooks to ensure they are securely engaged in the tow hook receivers.

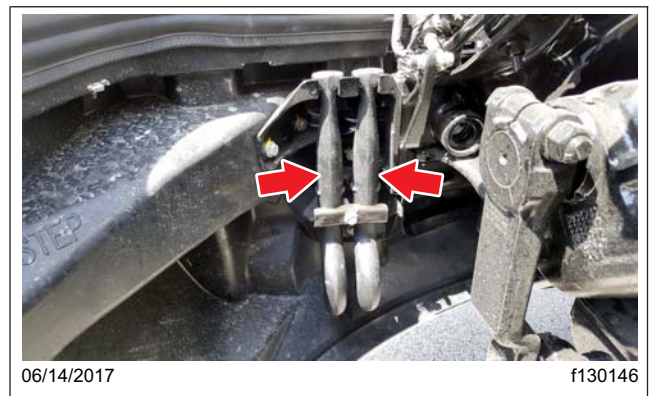

Fig. 23.6, Tow Hooks



Fig. 23.7, Tow Hooks Installed, Facing Down

5. Lower the stinger assembly so that it is level and approximately 1 inch (0.3 cm) off the ground. Back the tow truck so that the crossbar with lift adaptors is within 6 inches (15 cm) of the Aero bumper. See Fig. 23.8.

In an Emergency

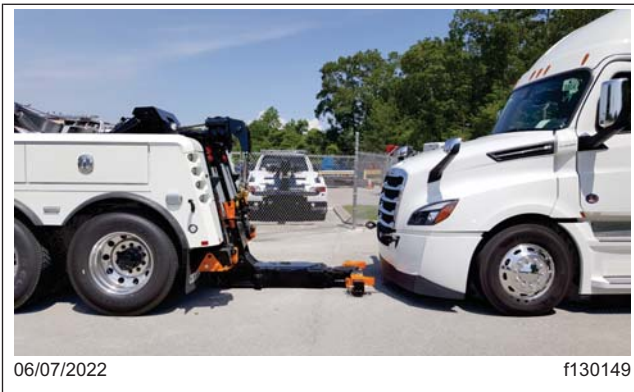

Fig. 23.8, Positioning the Stinger Assembly



Fig. 23.9, Tow Cables Connected to the Tow Hooks

NOTICE

When using tow hooks to move the vehicle, do not pass a sling (for example, a rope or chain) from one hook to another. Known as reeving, this practice is *not* permissible in most industrial applications of towing and hoisting. Reeving can overload the hooks and result in damage to the vehicle.

6. Pull the tow cables out of the tow truck and connect the tow cable lifting hooks onto the tow hooks, then extend the recovery boom within 4 to 6 inches (10 to 15 cm) of being vertical of the tow hooks. See [Fig. 23.9](#).
7. Lift the front of the truck until there is enough clearance for the stinger and crossbar to pass under the bumper. See [Fig. 23.10](#).

If enough clearance cannot be gained with a single lift, jack stands or other means capable of supporting the weight on the front axle must be used while the cables are shortened to allow a second lift.

WARNING

Failure to chock the tires or connect the tow truck's air brake system before releasing the spring parking brakes could allow the disabled vehicle to suddenly roll. This could cause property damage or personal injury.

8. Chock the rear tires.

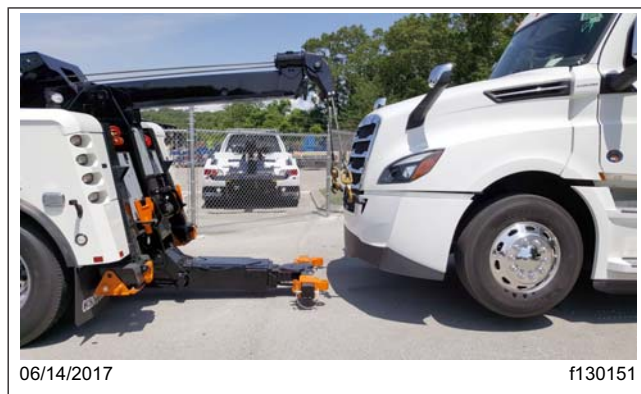

Fig. 23.10, Moving the Stinger and Crossbar Under the Bumper

NOTICE

Reference the applicable axle manufacturer's information to avoid damaging the axle when towing the truck.

9. Use mid-rise or high-rise forks, or lift adaptors (part number 0200020) on the crossbar to provide clearance for the aerodynamic bumper. See [Fig. 23.11](#) and [Fig. 23.12](#).
10. Extend the stinger and place the lift adaptors under the axle. Make certain the lift adaptors are under the front suspension springs between the U-bolts. See [Fig. 23.13](#) and [Fig. 23.14](#).
11. Secure the axle to the crossbar with a chain or ratchet strap.

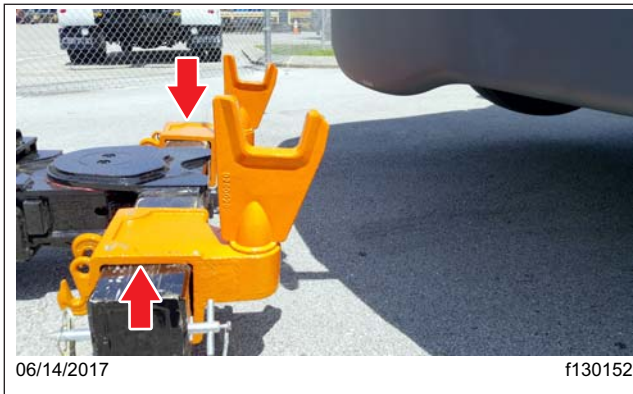

Fig. 23.11, Lift Adaptors Installed on the Crossbar

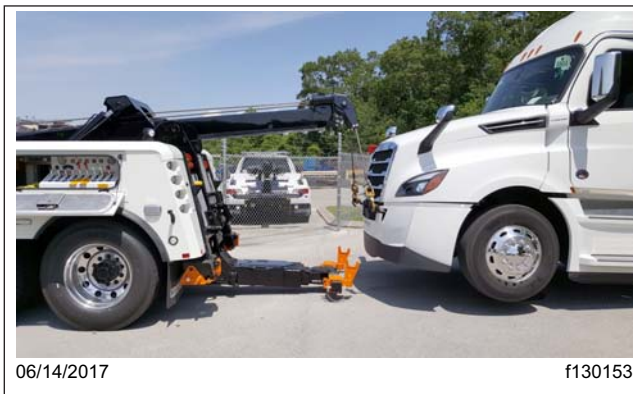

Fig. 23.12, Backing the Tow Truck with Lift Adaptors on the Crossbar

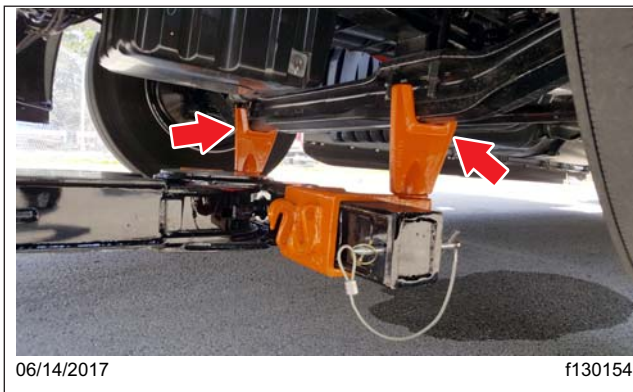

Fig. 23.13, Positioning the Stinger with Lift Adaptors Under the Axle

NOTICE

Failure to remove the driveline(s) or the drive axle shafts when towing the vehicle with the rear

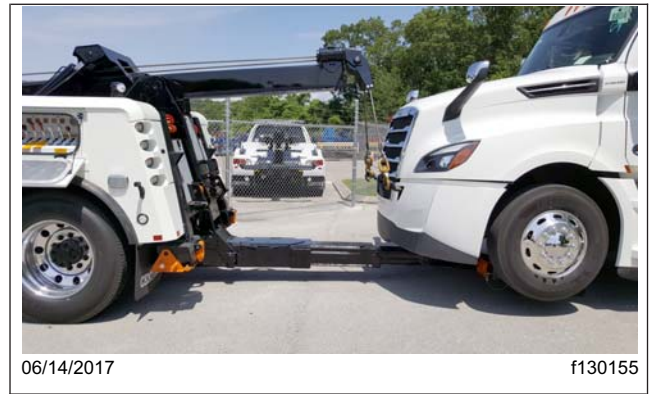

Fig. 23.14, Stinger with Lift Adaptors Under the Axle (tow truck shown)

wheels on the ground could result in damage to the transmission and other parts.

12. Use a paint pen to mark the drivelines in as built condition, and then remove the driveline, the interaxle driveline (if equipped), for each axle that may touch the ground during the towing process. Store the drivelines and U-joints in a secure location so they will not come off during transport.
13. Remove the tow cables from the tow hooks and retract the recovery boom. See [Fig. 23.15](#).



Fig. 23.15, Retracting the Recovery Boom

14. Remove the tow hooks from the bumper.

IMPORTANT: On trucks equipped with a front air suspension, either air pressure must be supplied to the secondary air system or the front suspension must be blocked to operating height with wooden spacers and the axle chained to the frame to prevent damage to the truck.

In an Emergency

15. Connect the air and electrical supply lines from the tow truck to the truck being towed.
16. Connect the clearance lights, taillights, and signal lights. Connect any special towing lights required by local regulations.
17. Release the park brake and remove the chocks from the rear tires.
18. Use the stinger to pull the truck close to the back of the tow truck for final towing position. See [Fig. 23.16](#).

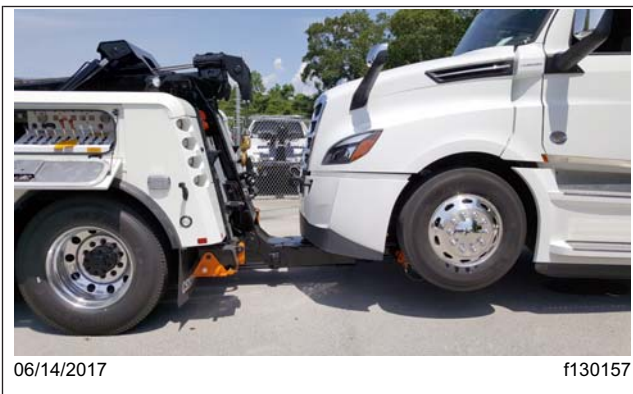

Fig. 23.16, Final Towing Position

19. Connect the safety chains. See [Fig. 23.17](#).

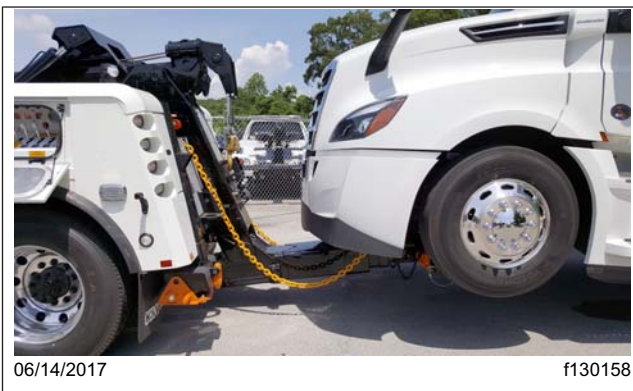

Fig. 23.17, Safety Chains Connected on the Towed Vehicle

Telematics Data

Telematics Information and Terms of Use	24.1
Frequency Bands and Maximum Transmission Output	24.3

Telematics Data

Telematics Information and Terms of Use

Your vehicle may be equipped with one or more devices that gather certain information (listed below) about the vehicle and the environment in which it is operating. These devices may periodically send this information ('telematic information') to Daimler Truck North American LLC (DTNA). Additionally DTNA and its dealers may manually retrieve 'telematics information' from devices on the vehicle for the purposes described below.

Telematics Information We Collect and Why We Collect it

The 'telematics information' we collect may include, but is not limited to, the following information about the vehicle:

- performance
- operation
- location
- speed
- trips
- travel history
- stop and idle times
- fuel consumption
- fault codes
- diagnostic information
- steering performance
- braking performance
- air bag deployment
- seatbelt use
- decelerations
- other information relating to the performance, operation, health and safety of the vehicle.

DTNA gathers this information to improve the performance, operation, health and safety of your vehicle and other DTNA vehicles and products. Information is gathered:

- **To enable your subscription services.** DTNA and other third party service providers have developed a variety of applications and services that are now available to you to

optimize the performance, use, reliability and safe operation of your vehicle. These services are enabled by the telematics information we receive from your vehicle and will likely be made more effective in the future by the use of that telematics information and similar information we receive from other DTNA vehicles.

- **To make your vehicle safer and to improve its performance.** Depending on the type of devices installed on your vehicle, DTNA may periodically update your vehicle's on-board software to improve the performance and safe use of the vehicle. We may need to obtain certain telematics information to ensure the effectiveness of these updates.
- **To monitor and manage the health and efficiency of your vehicle.** Telematics information from your vehicle may be used by DTNA and its affiliates, dealers, and service providers to more effectively diagnose and resolve problems with your vehicle and to help you maintain it.
- **To improve your customer service experience.** Telematics information may be used by DTNA and its affiliates, dealers, and service providers to provide you a more efficient and effective customer service experience in conjunction with vehicle service, maintenance, field service campaigns and recalls.
- **For product development and product improvement.** Telematics information may be analyzed and used to identify and resolve performance and safety issues and to develop improvements to our products that will benefit you and our future customers.
- **To develop more meaningful product marketing.** Telematics information may be used to provide more customized and meaningful information to our customers regarding products and services that best satisfy their operational requirements and improve the performance of their businesses.
- **To help match our customers with the right products.** Telematics information may be used to develop future products and services that best satisfy the operational requirements of our customers.

What We Do With Telematics Information and Who We Share it With

DTNA may use telematics information for any purpose allowed by law, including but not limited to using the information for any of the purposes described in this chapter. DTNA may share telematics information with its service providers, affiliates, subsidiaries, dealers, and distributors, but only for lawful business purposes. This may include third parties who process information on behalf of DTNA, third parties who you authorize directly to receive information from us, and law enforcement agencies pursuant to applicable law.

DTNA may also combine telematics information it obtains from your vehicle with data from others, anonymize and de-identify that aggregated data, and use and disclose that aggregated data and derivatives of it indefinitely and for any purpose whatsoever, including sharing it with third parties for any purpose without restriction. DTNA will be the exclusive owner of all rights, title and interests in and to all aggregated data. You will not have any rights in any aggregated data or any derivatives or proceeds of it. DTNA shall not have any obligation to provide any aggregated data to you or to compensate you for any use or disclosure of any aggregated data.

Collection Method

The telematics information may be transmitted automatically or manually from the devices on your vehicle to DTNA or Detroit Diesel Corporation (DDC) through diagnostic tools, including but not limited to DDC DiagnosticLink.

Safeguards

DTNA will use reasonable data security systems and procedures in an effort to protect telematics information from unauthorized use, access, disclosure, distribution, loss or alteration. We do this through physical, electronic and procedural safeguards that are designed to protect the confidentiality, integrity and availability of telematics information. However, no security system is perfect. DTNA cannot guarantee that telematics information will not be hacked, deleted, intercepted, or altered.

DTNA will also require other parties to whom telematics information is disclosed to take reasonable steps to protect the telematics information from

unauthorized use, access, disclosure, distribution, loss, or alteration.

Your Consent

By continuing to provide to us, or allowing us to receive or retrieve, telematics information through the devices on your vehicle, you consent to its collection and use as described in this chapter.

Although some information may be transferred to and processed in countries without laws providing the same level of data protection as your country, our use and disclosure of your information is subject to these terms of use regardless of where your information is transferred.

If you have subscribed to a subscription service such as Virtual Technician or Detroit Analytics, the Telematics Terms and Conditions for that service will apply to DTNA's collection, storage, use, and sharing of the data covered by those Telematics Terms and Conditions.

Your Rights

You may ask DTNA to discontinue receiving and retrieving telematics information from the devices on your vehicle. If you do so, you will be unable to receive telematics subscription services relating to your vehicle and remotely receive important vehicle software updates, among other things. If you are interested in that option, please contact DTNA at: **DetroitConnect@Daimler.com**.

Privacy Statement Changes

DTNA reserves the right to amend these terms of use from time to time. Changes will be reflected in the online version of this document, which can also be found at: <https://freightliner.com/service/driver-maintenance-manuals/>. **By continuing to provide to us, or allowing us to receive or retrieve, Telematics Information through the devices on your vehicle, you consent to and accept those changes.**

NOTE: These terms of use do not apply to aftermarket telematics devices that may be provided by others or configured to send information to someone other than DTNA or its affiliates, dealers or service providers.

Telematics Data

Frequency Bands and Maximum Transmission Output

Wireless Applications on the Vehicle

Frequency Bands and Maximum Transmission Output			
Component	Service	Frequency Band	Transmission Output
CTP2019DTNA	4G LTE	LTE FDD Band 2	0.25 W (Power Class 3)
		LTE FDD Band 4	
		LTE FDD Band 5	
		LTE FDD Band 7	
		LTE FDD Band 17	
	3G UMTS/HSDPA/HSUPA	UMTS Band 1	0.25 W (Power Class 3)
		UMTS Band 2	
		UMTS Band 4	
		UMTS Band 5	
	2G GSM/GPRS/EDGE	GSM 850 MHz	2 W (Power Class 4)
E-GSM 900 MHz		1 W (Power Class 1)	
DCS 1800 MHz			
	PCS 1900 MHz		
	WLAN (IEEE 802.11b)	2.4 GHz band	20 mW
	WLAN (IEEE 802.11g/n)	2.4 GHz band	20 mW
	Bluetooth	2.4 GHz band	10 mW
	GPS / GLONASS	1575 and 1602 MHz	Receive only

Table 24.1, Frequency Bands and Maximum Transmission Output

The Common Telematics Platform

The Detroit Connect Platform is the connectivity module of Daimler Truck North America. It receives and transmits data in real time and is the interface for all connectivity-related services. Both the Detroit Connect Platform and a valid agreement is required for use of the Detroit Connect services.

Vehicle antennas (WLAN/BT/CellularNetworks) are located inside and behind the dashboard on the passenger side. In both locations, the shortest possible distance between the antennas and any human or animal body part inside the vehicle cabin is greater than 8 in (20 cm).

Therefore Daimler Truck North America LLC declares that the radio equipment type CTP2019DTNA is in compliance with Directive 2014/53/EU.

Index

Subject	Page
A	
Adjustable Steering Column	4.1
Adjusting Headlight Aim	18.1
Air Brake System	11.1
Air Brake System, General Information	11.1
Air Brake System Operation	11.1
Automatic Slack Adjusters	11.3
Allison Automatic Transmissions	14.13
Automatic Mode (A)	14.14
General Information, Allison Transmissions	14.13
Low (L)	14.15
Manual Mode (M)	14.14
Operation Tips, Allison Transmissions	14.13
Transmission Prognostics	14.15
Allison On-Highway Transmissions	14.15
Operating Instructions, On-Highway Transmissions	14.17
Range Inhibit Indicator, 2000 and 2400 Series	14.16
Safety Precautions	14.16
Allison Transmission® MD Series	14.18
Operating Instructions, MD Series	14.18
Safety Precautions	14.18
Analog Instruments	3.18
Air Intake Restriction Gauge	3.18
Application Air Pressure Gauge	3.19
Coolant Temperature Gauge	3.19
Drive Axle Oil Temperature Gauges	3.20
Engine Oil Pressure Gauge	3.20
Engine Oil Temperature Gauge	3.21
Fuel/Diesel Exhaust Fluid (DEF) Gauge	3.21
Primary and Secondary Air Pressure Gauges	3.21
Speedometer	3.22
Suspension Air Pressure Gauge	3.22
Tachometer	3.22
Transmission Fluid Temperature Gauge	3.23
Turbocharger Boost Pressure Gauge	3.23
Voltmeter	3.23

Subject	Page
Automated/Automatic Transmission Shift Control	14.1
Direction Switch	14.1
Engine Brake	14.2
Gear Display	14.3
Gear Switch	14.1
Mode Switch	14.1
Power Up and Shift into Gear	14.2
Selected Gear (Detroit and Eaton Transmissions)	14.3
Suggested Shift (Detroit and Eaton Transmissions)	14.3
AWD Controls	4.9
Front Axle Transfer Case Range Switch	4.10
Front Axle Transfer Case Switch	4.9
B	
Back-of-Cab Access	2.4
Climbing Down from the Back-of-Cab	2.5
Climbing Up to the Back-of-Cab	2.5
Before Checking the Headlight Aim	18.1
Bench Seats	5.14
Bench Seats	5.14
Brake Hold	7.4
C	
Cab Amenities	5.1
Optional Features	5.1
Standard Features	5.1
Cab Entry and Exit	2.3
Entering from the Driver's Side	2.3
Entering from the Passenger's Side	2.4
Exiting from the Driver's Side	2.3
Exiting from the Passenger's Side	2.4
Cab Load Disconnect Switch	8.4
Canada Certification Label	1.1
Care of Exterior Lights	20.4
Care of Fiberglass Parts	20.5
Caring for External Chrome Components	20.4
Checking Headlight Aim	18.1
Checklists	21.1

Subject	Page	Subject	Page
Daily Pretrip Inspection Checklists	21.1	Active Brake Assist Collision Warning and Emergency Braking	6.6
Monthly Post-trip Inspection Checklists	21.2	Active Brake Assist Overview	6.5
Weekly Post-trip Inspection Checklist	21.1	Active Brake Assist Safety Information	6.5
Cleaning and Disinfecting Cab Surfaces	20.1	Detroit Assurance Adaptive Cruise Control (ACC)	6.2
Cleaning and Disinfecting Chemicals to Avoid	20.2	Adaptive Cruise Control Overview	6.3
Cleaning and Disinfecting High-Touch Surfaces	20.1	Adaptive Cruise Control Safety Information	6.2
Dashboard and Touch Screen Care	20.2	Detroit Assurance Collision Mitigation System (CMS)	6.1
Safety	20.1	Driver's Display	6.1
Cleaning the Upholstery	20.2	Detroit Assurance Lane Departure Warning (LDW)	6.11
Cleaning Cloth Seats	20.2	Activating or Deactivating Lane Departure Warning (LDW)	6.12
Faux Leather Cleaning	20.2	Cleaning the Windshield in the Area of the Camera	6.13
Vinyl Upholstery Cleaning	20.3	Functions and Activation Conditions for Lane Departure Warning	6.12
Clutch	15.5	Overview	6.12
Clutch Adjustment	15.6	Safety Notes on Lane Departure Warning	6.11
Clutch Operation	15.5	Detroit Assurance Side Guard Assist (SGA) and Active Side Guard Assist (ASGA)	6.13
General Information	15.5	Activating or Deactivating the Side Guard Assist	6.15
Component GWR Label	1.1	General Information	6.13
Component Information Label	1.1	Safety Information	6.14
Cruise Descent Control and Deceleration Modes	7.2	Sensor Monitoring Range	6.14
Deceleration Mode	7.3	SGA Indicator Lamps	6.14
Descent Control Mode	7.2	Warnings for Moving Objects	6.16
Customer Assistance Label	1.6	Warnings When Changing Lanes	6.16
D			
Daily Pretrip Inspections and Maintenance	22.1	Warnings When Turning Right for Stationary Obstacles	6.16
Cab Inspection	22.5	Warnings When Turning Right	6.16
Engine Compartment Inspection	22.4	Detroit Assurance Tailgate Warning	6.5
Saddle Tank Areas Inspection	22.4	Detroit Assurance Traffic Sign Display	6.17
Suspension and Slack Adjuster Inspection	22.1	Activating or Deactivating	6.19
Wheel and Tire Inspection	22.1	Active Speed Intervention	6.18
Dash-Mounted Brake Controls	4.6	General Information	6.17
Antilock Braking System	4.7	Safety Information	6.17
Parking Brake Control Valve	4.6	Traffic Sign Display Functionality	6.17
Trailer Air Supply Valve	4.6		
Trailer Brake Lever	4.7		
Detroit Assurance Active Brake Assist (ABA)	6.5		
Activating and Deactivating Active Brake Assist	6.6		

Index

Subject	Page
Traffic Sign Display With Speed Limit Emphasis	6.18
Traffic Sign Display With Warnings	6.18
Detroit Assurance Vehicle Cameras	6.1
Bendix Forward Facing Camera	6.2
Driver Facing Camera	6.2
Multipurpose Camera 2 (MPC2)	6.1
Rain/Light Sensor	6.2
Detroit™ Automated Transmissions (DT12)	14.3
Auto Neutral	14.7
Clutch Abuse Alerts and Protections	14.6
Clutch Abuse Protection	14.5
Creep Mode	14.4
Descent Control Mode	14.5
Driving Modes	14.3
eCoast	14.4
Engine Overspeed Alerts	14.5
Hill Descent Upshift Feature	14.6
Hill Start Aid (HSA)	14.5
Transmission Low Air Warning	14.6
Diesel Exhaust Fluid and Tank	13.7
DEF Tank	13.7
DEF Warnings and Engine Limits	13.7
Diesel Exhaust Fluid	13.7
Fuel/DEF Gauge	13.7
Digital Gauges and System Monitors: ICUC	3.11
Alerts	3.14
Application Air Pressure Gauge	3.13
Battery Voltage	3.14
Cruise Control	3.15
DEF and Diesel Particulate Filter Monitoring	3.13
Diagnostics	3.14
Engine Idle Adjust	3.16
Engine Maintenance	3.14
Engine Oil Temperature Gauge	3.11
ICUC Gauges	3.11
ICUC Vehicle Operations: Vehicle Settings	3.15
Maintenance System	3.14
Optimized Idle	3.16
Other ICUC Gauges and Measurements	3.13

Subject	Page
Suspension Air Pressure	3.15
Tire Pressure Monitoring System	3.13
Transmission Oil Temperature Gauge	3.12
Transmission Prognostics	3.15
Transmission	3.16
Turbocharger Boost Pressure Gauge	3.12
Driver Display Overview: ICUC	3.3
ICUC Alert Messages	3.3
ICUC Time and Alarm Settings	3.3
Main ICUC Driver Display Screens	3.4
Software Updates	3.10
Driver-Controlled Differential Lock (DCDL)	16.4
DCDL Operation	16.4
Differential Lock Switch	16.4
Single Drive Axles with Traction Equalizer	16.6

E

Eaton® Manual Transmissions	15.1
General Information	15.1
Transmission Operation Tips	15.1
Eaton® Range-Shift Transmissions	15.2
General Information, Range-Shift	15.2
Operation, Deep-Reduction Models	15.4
Operation, Range-Shift	15.3
Eaton® Straight-Shift Transmissions	15.1
General Information, Straight-Shift	15.1
Operation, Straight-Shift	15.2
Eaton™ Automated Transmissions	14.8
Auto Neutral	14.12
Auto Start Gear Selection and Override	14.12
Automatic Traction Control	14.12
Clutch Abuse Protection	14.11
Coasting	14.13
Creep Mode	14.11
Engine Overspeed Protection	14.12
Hill Start Aid	14.12
Load-Based Shifting	14.12
Multi-Function Stalk Switch	14.8

Subject	Page	Subject	Page
Push-Button Shift Selector	14.9	Pacbrake® Exhaust Brake	11.6
Shuttle Shifting	14.12	Exterior Lighting Controls	4.3
Skip Shifting	14.12	Automatic Headlamps	4.4
Transmission Low Air Warning	14.13	Auxiliary High Beam Lamps	4.4
Transmission Prognostics	14.13	Backup Lamps	4.6
Electronic Stability Control (ESC)	7.6	Daytime Running Lamps	4.4
Emergency Filter Replacement, Davco	23.1	Fog Lamps	4.4
Emergency Kit, Optional	23.1	Hazard Warning Lamps	4.4
Emergency Power Mode	8.5	Headlamp Switch	4.3
Emergency Starting With Jumper Cables	23.3	High-Beam Headlamps	4.4
Emission Labels	1.3	Intelligent High-Beam Headlamps	4.4
Aftertreatment System Indicators Label	1.3	Marker Interrupt Switch	4.4
Certified Clean Idle Label	1.6	Marker Lamps	4.4
Noise Emission Control Labels	1.5	Pretrip Light Test Switch	4.4
Vehicle Emission Control Information Label	1.4	Spotlamp	4.5
Engine Brake	11.3	Turn Signals	4.3
Engine Brake Operation	11.4	Utility Lamps	4.6
Engine Idle Limiting	10.1		
Idle Shutdown Timer	10.1	F	
Engine Operation	9.2	Federal Motor Vehicle Safety Standard Label	1.1
Cold-Weather Operation	9.3	Fifth Wheel Coupling	17.1
Engine Break-In	9.3	Fontaine Fifth Wheel Coupling	17.1
High-Altitude Operation	9.4	Holland Fifth Wheels Coupling	17.4
Normal Operation	9.3	Jost Fifth Wheel Coupling	17.7
Safety and Environmental Considerations	9.2	Trailer Auxiliary Switch	17.1
Engine Protection—Warning and Shutdown	9.4	Fifth Wheel Lubrication	17.1
Engine Shutdown	9.4	Fifth Wheel Slide	17.10
Engine Starting	9.1	Air Slide Operation	17.11
Cold-Weather Starting	9.2	Fifth Wheel Slide Control Switch	17.10
Starting After Extended Shutdown	9.2	Fifth Wheel Uncoupling	17.8
EPA-Regulated Emissions		Air-Actuated Uncoupling	17.9
Aftertreatment Systems	13.1	Manual Uncoupling	17.8
ATS Warning Lamps and Messages	13.4	Fire Extinguisher	23.1
EPA10 and Newer Engines	13.1	Fire in the Cab	23.1
Euro V Emission Compliant Engines for Export	13.1	In Case of a Cab Fire	23.1
Maintenance	13.6	Fluids Added	21.2
Regeneration	13.2	Frequency Bands and Maximum Transmission Output	24.3
Exhaust Braking Systems	11.4	The Common Telematics Platform	24.3
Exhaust Brake Switch	11.4	Wireless Applications on the Vehicle	24.3
Mercedes-Benz Exhaust Brake	11.5	Front Towing Hookup With Removable Tow Hooks	23.5
		Use of Tow Hooks	23.5

Index

Subject	Page
G	
Grab Handles and Access Steps	2.2
Greenhouse Gas Emissions and Fuel Consumption Standards	13.1
H	
Hazard Warning Lights	23.1
Hill Start Aid	7.3
Hood Opening and Closing	2.5
To Close the Hood	2.6
To Open the Hood	2.5
Horn Controls	4.6
Air Horn	4.6
Electric Horn	4.6
HVAC Controls	5.3
Air Conditioning	5.4
Air Vent Selection Switch	5.4
Fan Speed Switch	5.3
Recirculation Mode	5.4
Temperature Control Switch	5.4
Hydraulic Brake System	11.7
Hydraulic Brake System, General Information	11.7
Hydraulic Brake System Operation	11.7
I	
Ignition Switch and Key	4.1
Infotainment Controls	5.5
General Infotainment Information	5.5
ICUC Infotainment Screens	5.5
ICUC Radio Controls	5.5
Phone Controls	5.7
Physical Radio Controls	5.6
Safety Information	5.5
Weather Radio	5.6
Infotainment: ICUC	3.16
General ICUC Infotainment Information	3.17
ICUC Audio Features	3.17
ICUC Telephone Features	3.18
Navigation and Infotainment Reception	3.17
Safety Information	3.16
Instrumentation Control Unit:	
ICUC	3.1
ICUC Screen Navigation	3.2

Subject	Page
ICUC Steering Wheel Switch Pods	3.2
Ignition Sequence	3.1
Intelligent Powertrain Management (IPM)	7.5
Interaxle Lock, Tandem Axles	16.6
Interaxle Lock Operation	16.6
Interaxle Lock Switch	16.6
Interior Lighting Controls	5.2
Interior Lights	5.2
ISRI Basic High Back Seat	5.12
ISRI Premium High Back Seat	5.10
K	
Key, Door Locks, and Handles	2.1
L	
Limitations of Active Brake Assist and Adaptive Cruise Control	6.7
Lytx SF500 DriveCam System	7.8
Driver Facing Camera	7.8
M	
Major Repair and Replacement of Natural Gas Components	19.9
Meritor MTC Series Transfer Cases	15.6
Meritor MTC Series	15.6
Meritor WABCO® Antilock Braking System	11.7
Automatic Traction Control	11.8
Trailer ABS Compatibility	11.8
Meritor™ Drive Axles	16.1
Axle Shift	16.3
Drive Axles With Differential Lock	16.1
Tandem Drive Axles With Interaxle Lock	16.2
Mexico Labeling	1.2
Mexico Certification Label	1.2
Spanish Weights and Measures Label	1.2
Mirrors	5.8
Monthly Post-Trip Inspections and Maintenance	22.11
Brake Component Inspection	22.11
Engine Compartment Inspection and Adjustments	22.12

Subject	Page	Subject	Page
Saddle Tank Areas Inspection	22.12	Power Take-Off (PTO) Switch	4.9
		Transmission Controls	4.9
N		R	
Natural Gas Detection System	19.5	Raising and Lowering a Vehicle	23.4
Alarm Procedure	19.6	Lowering a Vehicle with Air Suspension	23.4
Control Module and Alarm Panel	19.7	Lowering a Vehicle without Air Suspension	23.5
Sensors	19.7	Raising a Vehicle with Air Suspension	23.4
Testing	19.9	Raising a Vehicle without Air Suspension	23.5
Natural Gas Engine Starting	19.2	Remote Keyless Entry	2.1
Natural Gas Fuel Tank Filling Procedures	19.2	Key Fob Programming	2.2
CNG Vehicle Fueling	19.2	Keyless Fob Use	2.1
LNG Vehicle Fueling	19.4	Specifications	2.2
Natural Gas Vehicles, General Information	19.1	RollTek Rollover Protection System	5.17
Natural Gas Vehicles, Safety Precautions	19.1		
In Case of Emergency	19.2	S	
O		Safety Precautions	22.1
Optimized Idle®	10.1	SafetyDirect® by Bendix	7.7
Activating Optimized Idle	10.2	Bendix Forward Facing Camera	7.7
Deactivating Optimized Idle	10.3	Driver Facing Camera	7.7
Reactivating Optimized Idle	10.3	The Bendix SafetyDirect Portal	7.7
Other Dash-Mounted Controls	4.11	Sears C-2 Plus Seat	5.13
Air Suspension Height Control Switch	4.11	Seat Slide Adjustment	5.13
Overhead Instrument Panel	3.24	Seat Belts	5.14
P		General Information	5.14
PasSmart	7.6	Seat Belt Inspection	5.15
Periodic Inspections and Maintenance, General Information	21.1	Seat Belt Operation	5.15
Power Distribution	8.2	Seats - General Information	5.8
Cab Electrical and Electronic Components	8.3	General Information	5.8
Power Takeoff (PTO) Governor	10.3	Sitting Posture	5.9
PTO Instrumentation Unit Controls	10.4	Standard Cruise Control	7.1
Powernet Management	8.5	Steering System	12.1
Powertrain Controls	4.7	Steering Wheel Adjustment Check	12.1
Aftertreatment System Regen Switches	4.7	System Overview	8.1
Axle Switches	4.8	The Instrumentation Control Unit (ICU) and Fault Codes	8.1
Engine Brake Switches	4.8	T	
Engine Fan Switch	4.8	Telematics Information and Terms of Use	24.1
Hill Start Aid Override Switch	4.9	Collection Method	24.2

Index

Subject	Page
Privacy Statement Changes	24.2
Safeguards	24.2
Telematics Information We Collect and Why We Collect it	24.1
What We Do With Telematics Information and Who We Share it With	24.2
Your Consent	24.2
Your Rights	24.2
Trailer Couplings	17.12
Holland Coupling Trailer Hookup	17.12
Holland Coupling Trailer Release	17.13
Holland Trailer Couplings	17.12
Premier Air Pintle Hitch Trailer Hookup	17.13
Premier Air Pintle Hitch Trailer Release	17.13

W

Warnings, Indicators, and Messages	3.24
Audible Alerts: ICUC	3.24
Engine Protection System	3.38
Warnings, Indicators, and Messages	3.24
Washing and Polishing the Cab	20.4
Keeping Your Vehicle Looking New	20.4
Protecting Vehicle Labeling	20.4
Protecting Your Vehicle's Finish	20.4
Weekly Post-Trip Inspections and Maintenance	22.9
Engine Compartment Inspection	22.9
Windows	5.7
Windshield Wiper and Washer Controls	4.1
Windshield Washers	4.3
Wiper Controls	4.2
Wipers and the Rain/Light Sensor	4.2